

Improve Reliability of Desalter Interface Measurement While Reducing Maintenance with the use of Guided Wave Radar

Introduction

This document provides information on improving reliability of desalter interface measurement and reducing maintenance with the use of Guided Wave Radar (GWR) transmitters.

Potential Results

By using GWR, the potential results include

- More efficient operation of desalter minimizes corrosion of refinery equipment and reduces risk of over-pressuring crude distillation column
- Eliminate need to re-span measurement output when density changes
- Reliable interface measurement prevents oil from entering waste water stream
- Reliable interface measurement can improve quality of the oil for downstream usage
- Reliable interface measurement allows automation and increases throughput

Application Background

Raw crude oil contains a lot of salt contaminants and water. If the salts are not removed, then they can cause significant corrosion of downstream refinery equipment due to high operating temperatures. To remove the salts, emulsifying chemicals and additional water are mixed with the oil to wash the salts out of the oil. This emulsified oil water mixture then needs to be separated quickly and efficiently. An electrostatic grid causes the dispersed water droplets and salts to coalesce and drop. This electro-static field operates at maximum efficiency when the water and oil interface is maintained at a level just below the electrostatic grid.

In refineries, a desalter is used to separate crude oil from water using an electro-static grid operating at about 10KV. A reliable interface measurement is needed to allow it to run at optimal efficiency without the risk of water getting into the grid.

When operators do not have confidence in the interface level measurement they will operate these units at a low interface level to prevent tripping the unit. This lessens the efficiency of the unit and reduces throughput.

Key Characteristics: Crude oil on water with 6 to 12 inch (150 to 300 mm) emulsion layer in a vessel with a 10 to 22 kV electrostatic grid.

Crude oil API gravity varies with source of supply. Normally desalters are operated between 165-190 PSIG (11 to 13 Bar) with a max of 215 PSIG (15 Bar). The operating temperature is typically 265-275 F (129- 135C) with a max of 300 F (150 C).

Traditional technologies used for measurement: Displacers, capacitance, or magnetostrictive, all with frequent manual verification.

Emerson Process Management

Rosemount Inc.
8200 Market Boulevard
Chanhassen, MN 55317 USA
T (U.S.) 1-800-999-9307
T (International) (952) 906-8888
F (952) 949-7001

www.rosemount.com

Fig 1: Schematic drawing indicating the key components in a desalter application

It is very important to know the actual interface level to avoid tripping the electrical grid. If the water and salt layer contact the grid, the excessive high current would trip it.

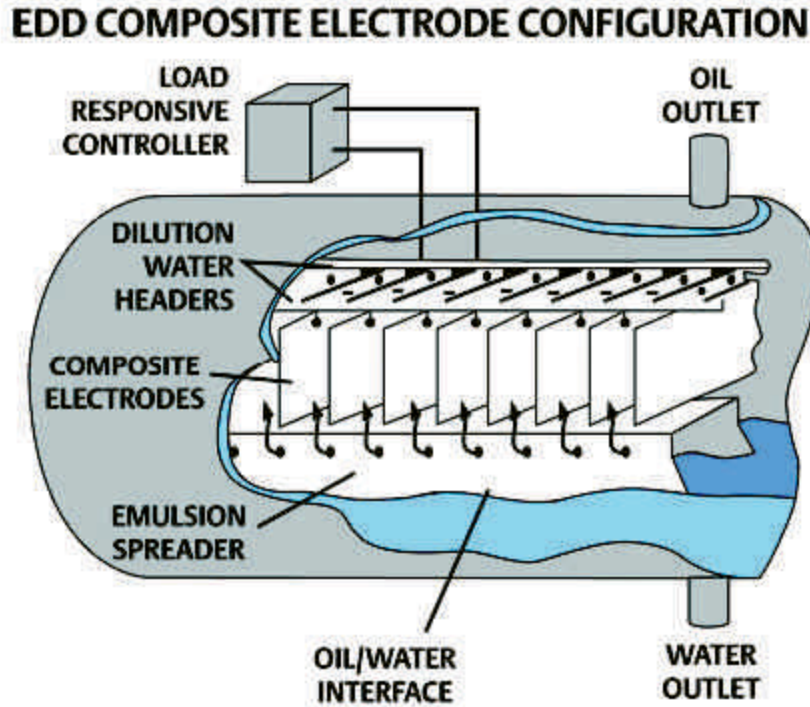

Challenge

This application is a challenging interface measurement. The oil and water layers both have varying properties. The properties of the oil, especially the density, change with different crude supplies and as the fluid is heated. The water density will change with the amount of contaminants and the heat. The crude can contain sticky components that tend to build up on surfaces, coat probes, or cause mechanical parts to stick. The presence of the emulsion, or rag layer, creates an indistinct interface between the fluids which can be difficult to read.

Displacers, magnetostrictive, or capacitance technologies have traditionally been used to measure the interface level. Changes in oil density require that displacers be re-spanned which results in extra maintenance time. If the torque tube requires recalibration, the unit has to be taken out of service. Capacitance probes are susceptible to errors due to coating. This results in instability and unpredictable measurements.

Because of the various challenges of the technologies and the critical need to know the interface, desalters have been built with bleed taps so that the interface location can be manually verified.

Emerson Process Management

Rosemount Inc.
8200 Market Boulevard
Chanhassen, MN 55317 USA
T (U.S.) 1-800-999-9307
T (International) (952) 906-8888
F (952) 949-7001

www.rosemount.com

White paper: Improve Reliability of Desalter Interface Measurement while Reducing Maintenance with the use of Guided Wave Radar

June, 2009 – Page 3

If displacers are used, they are often installed in a stilling well. Capacitance probes are often installed directly in the vessel in a location where they will not contact the grid.

Fig 2. Bleed taps in the area near the desired interface level allow manual verification of the interface.



SOLUTION

Guided Wave Radar offers several advantages for this application. It is immune to density changes, can handle coating and has no moving parts to maintain. It can measure both level and interface and is easy to set up and configure. The presence of the electrostatic grid has no impact on the instrument operation provided the unit is grounded and installed to local codes.

In one desalter that had previously used a displacer, a Rosemount Guided Wave Radar with a flexible single lead was installed in the 6" stilling well with slots. In another unit, a rigid twin probe was used within the stilling well. Both worked, but to reduce long term maintenance, the single lead probe is recommended.

In another application, a Rosemount Guided Wave Radar with a rigid single lead probe was used to replace a capacitance probe. The use of a rigid probe help to minimize movement of the probe. This one also worked well.

To verify that the interface levels from each of these radar transmitters was correct, the operators were able to manually check for the presence of oil or water by using a series of taps on the side of vessel. In each case, the interface reading from the transmitter corresponded to the area between the correct oil and water taps. In addition, the control systems showed a stable trend line and control was achievable to within 3 to 4% of the set point.

Emerson Process Management

Rosemount Inc.
8200 Market Boulevard
Chanhassen, MN 55317 USA
T (U.S.) 1-800-999-9307
T (International) (952) 906-8888
F (952) 949-7001

www.rosemount.com

White paper: Improve Reliability of Desalter Interface Measurement while Reducing Maintenance with the use of Guided Wave Radar

June, 2009 – Page 4

Fig 3. The Guided Wave Radar can be installed inside a slotted stilling well within the vessel. It can also be installed directly into the desalter as long as the probe does not contact the grid or any other metallic obstacles. The electronic grid of the desalter does not disturb the signal.

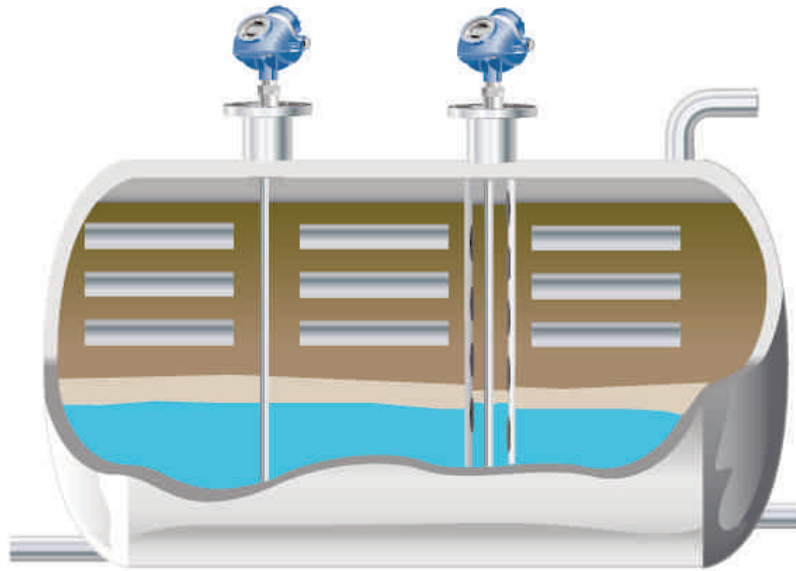

Heat rising from the vessel may exceed the ambient temp limit of the electronics when mounted close to the vessel. This may cause the ambient temperature limits of the electronics head to be exceeded. To prevent this, there are a number of options: Elevate the electronics head with a spool piece; use an HP (high pressure and higher temperature) probe, or use a remote extension for the electronics.

Fig 4. Heat rising from the vessel can exceed the ambient temperature limit. This can be avoided by either: 1) The addition of a spool piece, 2) Using an High Pressure probe, or 3) Using a remote connection.

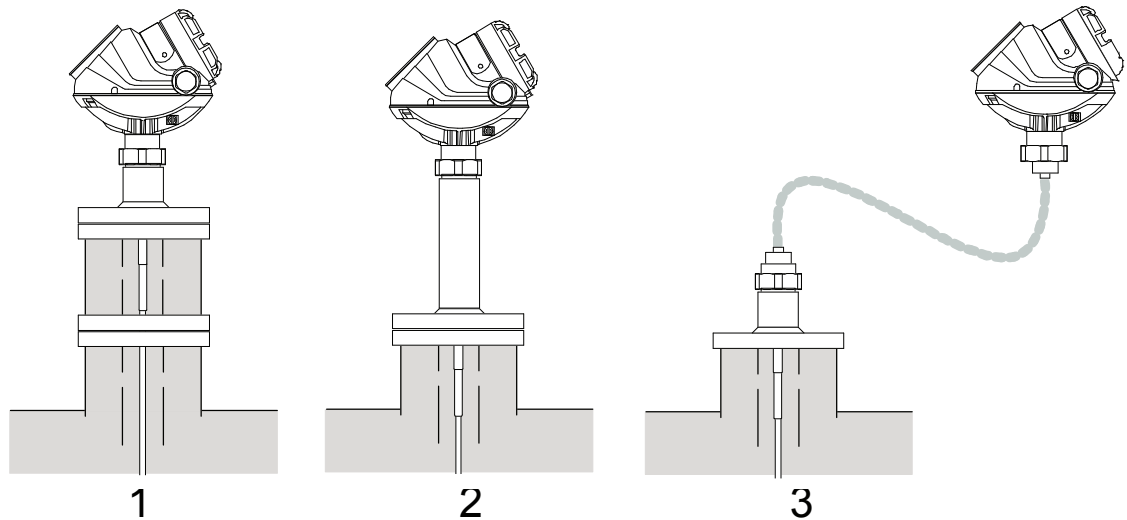

Emerson Process Management

Rosemount Inc.
8200 Market Boulevard
Chanhassen, MN 55317 USA
T (U.S.) 1-800-999-9307
T (International) (952) 906-8888
F (952) 949-7001

www.rosemount.com

Probe coating potential

Crude oil can contain sticky components that tend to build up on surfaces, coat probes, or cause mechanical parts to stick. Some key advantages of Guided Wave Radar technology is that it is more tolerant of material buildup on the probe surface and has no moving parts. The use of a single lead probe helps to eliminate any bridging that could create a false target if coaxial or twin lead probes were used. An additional feature of the Rosemount 5300 is its Signal Quality diagnostics. With this feature, the strength of the signal in relation to any buildup can be monitored over time to ensure the signal is not degrading and remains reliable.

Fig 5.

Signal Quality Metrics can be used to assure signal strength remains reliable.

NOTE: These plots are for illustration only.

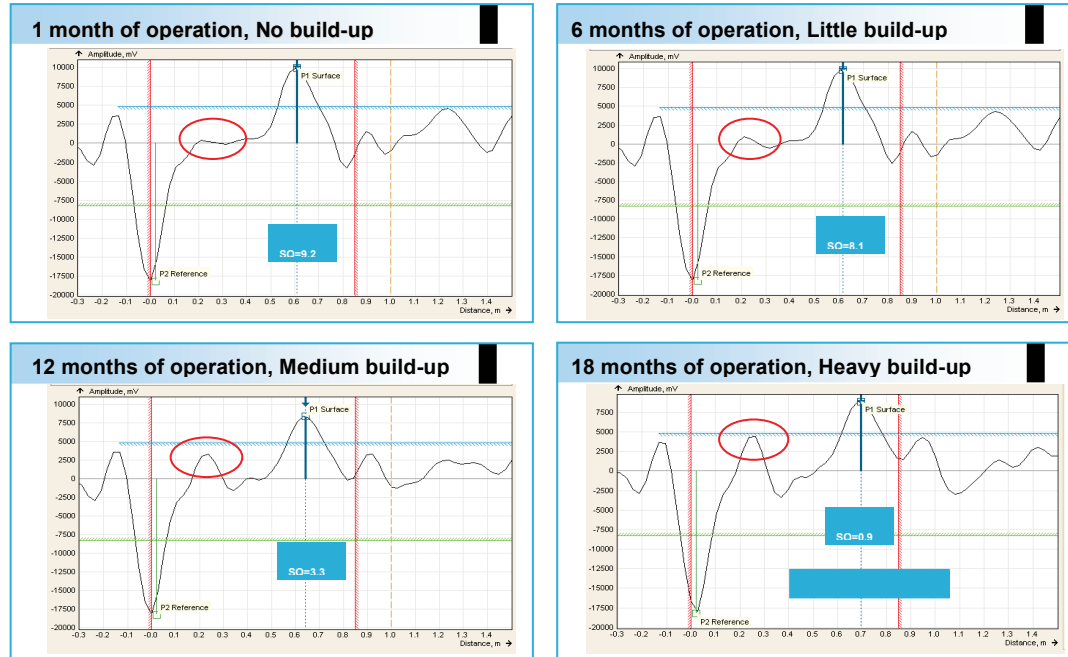

Emulsion Layers

One of the challenges of this measurement is the presence of a wide emulsion layer between the oil and the water. In applications using a stilling well, the pipe may create a settling effect and cause the emulsion to be reduced. In applications where the probe is installed without a stilling well, the probe may see the entire emulsion layer. This emulsion can cause the interface layer to be less distinct than normal. Since the interface peak tends to be smaller than normal, some manual setting of the transmitter thresholds may be required. By comparing the manual tap samples and the interface measurement, it can be verified that the Guided Wave Radar transmitter will read the top of the emulsion layer. Repeatable measurement of the emulsion layer can provide good interface control of the desalter. In some cases, it may be possible to see the bottom of the emulsion layer however this needs to be determined on a case by case basis as the results depend on the crude oil properties.

Emerson Process Management

Rosemount Inc.
8200 Market Boulevard
Chanhassen, MN 55317 USA
T (U.S.) 1-800-999-9307
T (International) (952) 906-8888
F (952) 949-7001

www.rosemount.com



White paper: Improve Reliability of Desalter Interface Measurement while Reducing Maintenance with the use of Guided Wave Radar

June, 2009 – Page 6

Results

Efficient operation of the desalting unit can minimize the effects of corrosion and fouling in downstream process units. Additionally, controlling the percentage of water in oil can reduce the potential of over-pressuring of the crude distillation column.

With reliable interface level control, a desalter is able to operate more efficiently with reduced water and salt carryover to the crude unit. Effective separation of the oil improves its quality and reduces oil contamination to downstream water treatment plant. The need for maintenance and associated downtime is eliminated.

The contents of this publication are presented for informational purposes only, and while effort has been made to ensure their accuracy, they are not to be construed as warranties or guarantees, express or implied, regarding the products or services described herein or their use or applicability. All sales are governed by our terms and conditions, which are available on request. We reserve the right to modify or improve the designs or specifications of our products at any time without notice.

Rosemount and the Rosemount logotype are registered trademarks of Rosemount Inc.
All other marks are the property of their respective owners.

Emerson Process Management

Rosemount Inc.
8200 Market Boulevard
Chanhassen, MN 55317 USA
T (U.S.) 1-800-999-9307
T (International) (952) 906-8888
F (952) 949-7001

www.rosemount.com