

Rosemount 648 Wireless Temperature Transmitter

Product Discontinued



ROSEMOUNT®

www.rosemount.com

EMERSON™
Process Management

Rosemount 648 Wireless Temperature Transmitter

Rosemount 648 Hardware Revision	1
HART® Device Revision	1
Field Communicator Field Device Revision	Dev v1, DD v4

NOTICE

Read this manual before working with the product. For personal and system safety, and for optimum product performance, make sure to thoroughly understand the contents before installing, using, or maintaining this product.

The United States has two toll-free assistance numbers and one international number.

Customer Central

1-800-999-9307 (7:00 a.m. to 7:00 P.M. CST)

National Response Center

1-800-654-7768 (24 hours a day)

Equipment service needs

International

1-(952) 906-8888

⚠ CAUTION

The products described in this document are NOT designed for nuclear-qualified applications.

Using non-nuclear qualified products in applications that require nuclear-qualified hardware or products may cause inaccurate readings.

For information on Rosemount nuclear-qualified products, contact a Emerson Process Management Sales Representative.

Rosemount 648 Wireless Temperature Transmitter may be protected by one or more U.S. Patents pending. Other foreign patents pending.

⚠ WARNING

Explosions could result in death or serious injury:

Installation of this transmitter in an explosive environment must be in accordance with the appropriate local, national, and international standards, codes, and practices. Please review the approvals section of the 648 reference manual for any restrictions associated with a safe installation.

- Before connecting a Field Communicator in an explosive atmosphere, ensure the instruments are installed in accordance with intrinsically safe or non-incendive field wiring practices.

Process leaks may cause harm or result in death.

- Install and tighten process connectors before applying pressure.

Electrical shock can result in death or serious injury.

- Avoid contact with the leads and terminals. High voltage that may be present on leads can cause electrical shock.

NOTICE

The Rosemount 648 and all other wireless devices should be installed only after the 1420 Wireless Gateway has been installed and is functioning properly. Wireless devices should also be powered up in order of proximity from the 1420 Wireless Gateway, beginning with the closest. This will result in a simpler and faster network installation.

NOTICE

Shipping considerations for wireless products (Lithium Batteries):

The unit was shipped to you without the battery installed. Please remove the battery pack from the unit prior to shipping.

Primary lithium batteries are regulated in transportation by the U. S. Department of Transportation, and are also covered by IATA (International Air Transport Association), ICAO (International Civil Aviation Organization), and ARD (European Ground Transportation of Dangerous Goods). It is the responsibility of the shipper to ensure compliance with these or any other local requirements. Please consult current regulations and requirements before shipping.

The battery pack with the wireless unit contains two “C” size primary lithium/thionyl chloride batteries. Each battery contains approximately 2.5 grams of lithium, for a total of 5 grams in each pack. Under normal conditions, the battery materials are self-contained and are not reactive as long as the batteries and the pack integrity are maintained. Care should be taken to prevent thermal, electrical or mechanical damage. Contacts should be protected to prevent premature discharge.

Battery hazards remain when cells are discharged.

Batteries should be stored in a clean and dry area. For maximum battery life, storage temperature should not exceed 30° C.

Table of Contents

Shipping considerations for wireless products (Lithium Batteries):. 0-2

SECTION 1 Overview

Safety Messages	1-1
Warnings	1-1
Overview	1-2
Manual	1-2
Transmitter	1-2
Considerations	1-3
General	1-3
Commissioning	1-3
Mechanical	1-3
Electrical	1-3
Environmental	1-4
Return of Materials	1-5

SECTION 2 Configuration

Safety Messages	2-1
Warnings	2-1
Sensor Connections	2-2
Device Sensor Configuration	2-6
Device Network Configuration	2-6
HART Menu Tree	2-8
Fast Key Sequence	2-9
Calibration	2-9
Alerts	2-12
Remove Battery	2-13

SECTION 3 Mounting

Safety Messages	3-1
Warnings	3-1
Mounting	3-2
Direct Mount	3-2
Remote Mount	3-4
LCD Display	3-5
Ground the Transmitter	3-5

SECTION 4 Commissioning

Safety Messages	4-1
Warnings	4-1
Verify Operation	4-2

SECTION 5 Operation and Maintenance

Safety Messages	5-1
Warnings	5-1
LCD Screen Messages	5-2
Startup Screen Sequence	5-2
Diagnostic Button Screen Sequence	5-3
Network Diagnostic Status Screens	5-4
Device Diagnostic Screens	5-6
Battery Replacement	5-9

APPENDIX A
Specifications and
Reference Data

Specifications A-1
 Functional Specifications A-1
 Physical Specifications A-1
 Performance Specifications A-2
 Accuracy A-3
 Ambient Temperature Effect A-4
Dimensional Drawings A-5
Ordering Information A-6

APPENDIX B
Product Certifications

Approved Manufacturing Locations B-1
Telecommunication Compliance B-1
FCC and IC B-1
European Union Directive Information B-1
Ordinary Location Certification for FM B-2
Hazardous Locations Certificates B-2

Section 1 Overview

Safety Messages	page 1-1
Overview	page 1-2
Considerations	page 1-3
Return of Materials	page 1-5

SAFETY MESSAGES

Instructions and procedures in this section may require special precautions to ensure the safety of the personnel performing the operations. Information that potentially raises safety issues is indicated by a warning symbol (⚠). Please refer to the following safety messages before performing an operation preceded by this symbol.

Warnings

⚠ WARNING

Failure to follow these installation guidelines could result in death or serious injury.

- Make sure only qualified personnel perform the installation.

Explosions could result in death or serious injury.

- Before connecting a 375 Field Communicator in an explosive atmosphere, make sure the instruments are installed in accordance with intrinsically safe or non-incendive field wiring practices.
- Verify that the operating atmosphere of the transmitter is consistent with the appropriate hazardous locations certifications.

Process leaks could result in death or serious injury.

- Do not remove the thermowell while in operation.
- Install and tighten thermowells and sensors before applying pressure

Electrical shock could cause death or serious injury.

- Use extreme caution when making contact with the leads and terminals.

OVERVIEW

Manual

This manual is designed to assist in the installation, operation, and maintenance of Rosemount 648.

Section 1: Overview

- Manual and Transmitter Overview
- Considerations
- Return of Materials

Section 2: Configuration

- Device Sensor Configuration
- Device Network Configuration

Section 3: Mounting

- Mount the Sensor
- Sensor Assembly/Leads
- Grounding
- LCD Rotation

Section 4: Commissioning

- Network Status
- Verify Operation

Section 5: Operation and Maintenance

- LCD Screen Messages
- LCD Rotation
- Battery Replacement

Appendix A: Specifications and Reference Data

- Specifications
- Dimensional drawings
- Ordering Information

Appendix B: Approvals

- Product Certifications
- Installation Drawings

Transmitter

Features of the Rosemount 648 include:

- An installation-ready solution that provides a variety of mounting options, transmitter configurations, and sensors/thermowells
- 4 user configurable alerts
- Flexibility to meet your most demanding applications
- Wireless output with >99% data reliability delivers rich HART data, protected by industry leading security
- The Transmitter-Sensor Matching feature improves temperature measurement accuracy by up to 75% when compared to unmatched assemblies.

- The integral LCD conveniently displays the primary sensor input and diagnostics of the transmitter
- Simple and easy installation practices already used today for robust installations

Refer to the following literatures for a full range of compatible connection heads, sensors, and thermowells provided by Emerson Process Management.

- English Temperature Sensors and Assemblies Product Data Sheet, Volume 1 (document number 00813-0100-2654)
- Temperature Sensors and Accessories (Metric Sensors) Product Data Sheet, Volume 2 (document number 00813-0200-2654)

CONSIDERATIONS

General

Electrical temperature sensors such as RTDs and thermocouples produce low-level signals proportional to their sensed temperature. With simple HART configuration, the Rosemount 648 converts the low-level sensor signal to a wireless-enabled signal.

Commissioning

The transmitter can be commissioned before or after installation. It may be useful to commission it on the bench, before installation, to ensure proper operation and to become familiar with its functionality. When applicable, make sure the instruments are installed in accordance with intrinsically safe or non-incendive field wiring practices. The device will be powered whenever the battery is installed. To avoid depleting the battery, make sure it is removed when the device is not in use.

Mechanical

Location

When choosing an installation location and position, take into account the need for access to the transmitter. For best performance, the antenna should be vertical with some space between objects in a parallel metal plane such as a pipe or metal framework, as the pipes or framework may adversely affect the performance of the antenna.

Electrical

Battery

The Rosemount 648 Wireless Temperature transmitter is battery powered. The battery pack with the wireless unit contains 2 "C" size primary lithium/thionyl chloride batteries. Each battery contains approximately 2.5 grams of lithium, for a total of 5 grams in each pack. Under normal conditions, the battery materials are self-contained and are not reactive as long as the batteries and the battery pack are maintained. Care should be taken to prevent thermal, electrical or mechanical damage. Contacts should be protected to prevent premature discharge.

 Use caution when handling the battery pack. The battery pack may be damaged if dropped from heights in excess of 20 feet.

Sensor

Make sensor connections through the cable entry in the side of the connection head. Be sure to provide adequate clearance for cover removal.

Environmental

Verify that the operating atmosphere of the transmitter is consistent with the appropriate hazardous locations certifications.

Temperature Effects

The transmitter will operate within specifications for ambient temperatures between -40 and 185 °F (-40 and 85 °C). Heat from the process is transferred from the thermowell to the transmitter housing. If the expected process temperature is near or beyond specification limits, consider the use of additional thermowell and extension, or remote mounting the transmitter to thermally isolate it from the process.

Figure 1-1 provides an example of the relationship between transmitter housing temperature rise and thermowell extension length.

Figure 1-1. 648 Transmitter Connection Head Temperature Rise vs. Extension Length

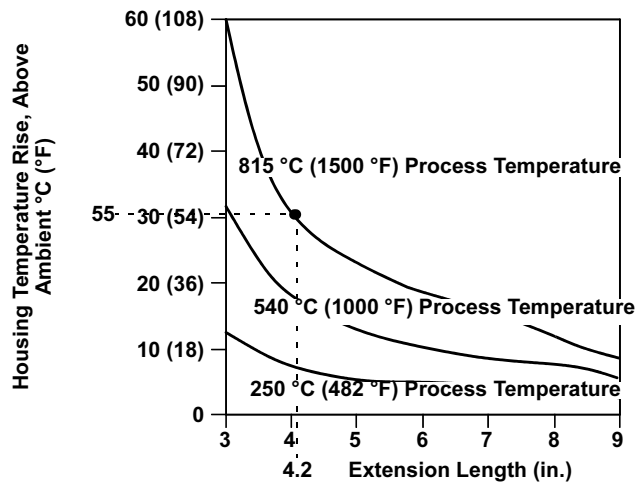

Example

The transmitter specification limit is 85 °C. If the ambient temperature is 55 °C and the max process temperature to be measured is 815 °C, the maximum permissible connection head temperature rise is the transmitter specification limit minus the ambient temperature (moves 85 to 55 °C), or 30 °C.

In this case, an extension of 5” meets this requirement, but 6” provides an additional margin of thermowell protection, thereby reducing risk of ambient thermal damage.

Temperature Limits

	Operating Limit	Storage Limit
With LCD Display	-4 to 175 °F -20 to 80 °C	-40 to 185 °F -40 to 85 °C
Without LCD Display	-40 to 185 °F -40 to 85 °C	-40 to 185 °F -40 to 85 °C

RETURN OF MATERIALS

To expedite the return process in North America, call the Emerson Process Management National Response Center toll-free at 800-654-7768. This center, available 24 hours a day, will assist you with any needed information or materials.

 The center will ask for the following information:

- Product model
- Serial numbers
- The last process material to which the product was exposed

The center will provide

- A Return Material Authorization (RMA) number
- Instructions and procedures that are necessary to return goods that were exposed to hazardous substances

For other locations outside North America, please contact an Emerson Process Management sales representative for further instructions.

NOTE

If the device has been exposed to a hazardous substance, a Material Safety Data Sheet (MSDS) must be included with the returned materials. An MSDS is required by law to be available to people exposed to specific hazardous substances.

SHIPPING CONSIDERATIONS FOR WIRELESS PRODUCTS (LITHIUM BATTERIES):

The unit was shipped to you without the battery installed. Please remove the battery pack prior to shipping the unit.

Primary lithium batteries (charged or discharged) are regulated in transportation by the U.S. Department of Transportation, and are also covered by IATA (International Air Transport Association), ICAO (International Civil Aviation Organization), and ARD (European Ground Transportation of Dangerous Goods). It is the responsibility of the shipper to ensure compliance with these or any other local requirements. Please consult current regulations and requirements before shipping.

Section 2 Configuration

Safety Messages	page 2-1
Device Sensor Configuration	page 2-6
Device Network Configuration	page 2-6
Fast Key Sequence	page 2-9
Remove Battery	page 2-13

SAFETY MESSAGES

Instructions and procedures in this section may require special precautions to ensure the safety of the personnel performing the operations. Information that potentially raises safety issues is indicated by a warning symbol (⚠). Please refer to the following safety messages before performing an operation preceded by this symbol.

Warnings

⚠ WARNING

Failure to follow these installation guidelines could result in death or serious injury.

- Make sure only qualified personnel perform the installation.

Explosions could result in death or serious injury.

- Before connecting a 375 Field Communicator in an explosive atmosphere, make sure the instruments are installed in accordance with intrinsically safe or non-incendive field wiring practices.
- Verify that the operating atmosphere of the transmitter is consistent with the appropriate hazardous locations certifications.

Process leaks could result in death or serious injury.

- Do not remove the thermowell while in operation.
- Install and tighten thermowells and sensors before applying pressure

Electrical shock could cause death or serious injury.

- Use extreme caution when making contact with the leads and terminals.

This device complies with Part 15 of the FCC Rules. Operation is subject to the following conditions: This device may not cause harmful interference, this device must accept any interference received, including interference that may cause undesired operation.

This device must be installed to ensure a minimum antenna separation distance of 20 cm from all persons.

Sensor Connections

The 648 is compatible with a number of RTD and thermocouple sensor types. Figure 2-1 shows the correct input connections to the sensor terminals on the transmitter. To ensure a proper sensor connection, anchor the sensor lead wires into the appropriate compression terminals and tighten the screws.

Thermocouple or Millivolts Inputs

The thermocouple can be connected directly to the transmitter. Use appropriate thermocouple extension wire if mounting the transmitter remotely from the sensor. Make millivolt inputs connections with copper wire. Use shielding for long runs of wire.

RTD or Ohm Inputs

The transmitters will accept a variety of RTD configurations, including 2-wire, 3-wire, 4-wire. If the transmitter is mounted remotely from a 3-wire or 4-wire RTD, it will operate within specifications, without recalibration, for lead wire resistances of up to 5 ohms per lead (equivalent to 500 feet of 20 AWG wire). In this case, the leads between the RTD and transmitter should be shielded. If using only two leads, both RTD leads are in series with the sensor element, so significant errors can occur if the lead lengths exceed three feet of 20 AWG wire (approximately 0.05 °C/ft.). For longer runs, attach a third or fourth lead as described above.

Sensor Lead Wire Resistance Effect—RTD Input

When using a 4-wire RTD, the effect of lead resistance is eliminated and has no impact on accuracy. However, a 3-wire sensor will not fully cancel lead resistance error because it cannot compensate for imbalances in resistance between the lead wires. Using the same type of wire on all three lead wires will make a 3-wire RTD installation as accurate as possible. A 2-wire sensor will produce the largest error because it directly adds the lead wire resistance to the sensor resistance. For 2- and 3-wire RTDs, an additional lead wire resistance error is induced with ambient temperature variations. The table and the examples shown below help quantify these errors.

Table 2-1. Examples of Approximate Basic Error

Sensor Input	Approximate Basic Error
4-wire RTD	Negligible (independent of lead wire resistance up to 5 Ω per lead)
3-wire RTD	± 1.0 Ω in reading per ohm of unbalanced lead wire resistance (Unbalanced lead wire resistance = maximum imbalance between any two leads.)
2-wire RTD	1.0 Ω in reading per ohm of lead wire resistance

Figure 2-1. Sensor Wiring Diagrams

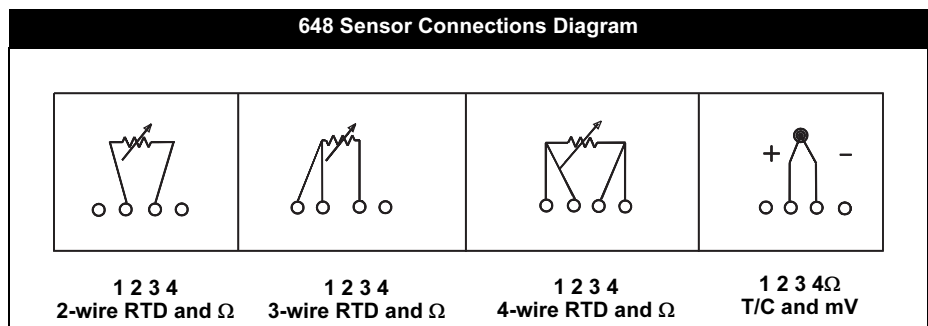
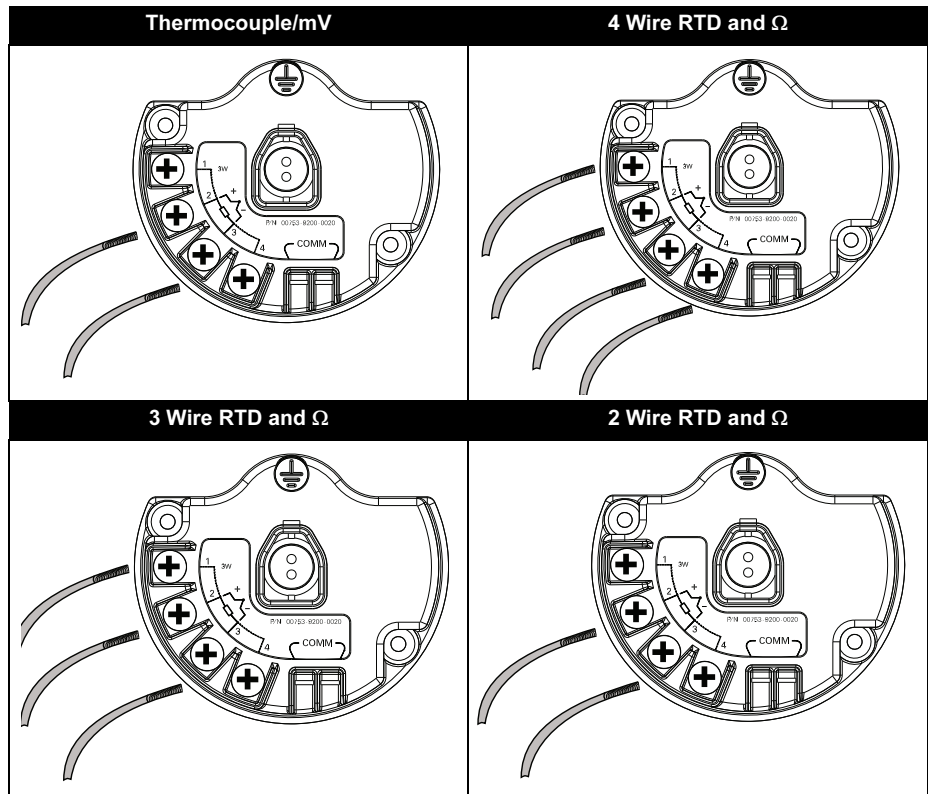

**Emerson Process Management provides 4-wire sensors for all single element RTDs. Use these RTDs in 3-wire configurations by leaving the unneeded leads disconnected and insulated with electrical tape.*

Figure 2-2. Rosemount 68Q, 78 Standard Temperature Range, and 58C RTD Sensor Lead Wire Configurations



Figure 2-3. Rosemount 65, 78 High Temp, 68 RTD Lead Wire Configurations

Single Element

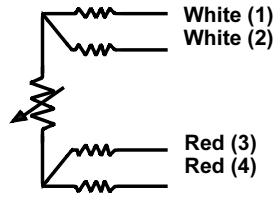

Figure 2-4. Rosemount 183 Thermocouple Lead Wire Configuration

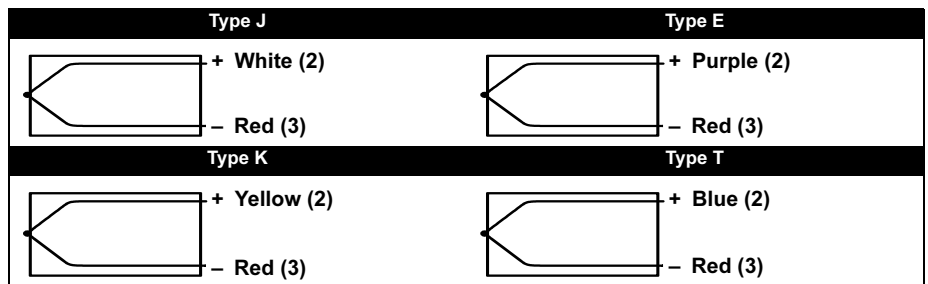
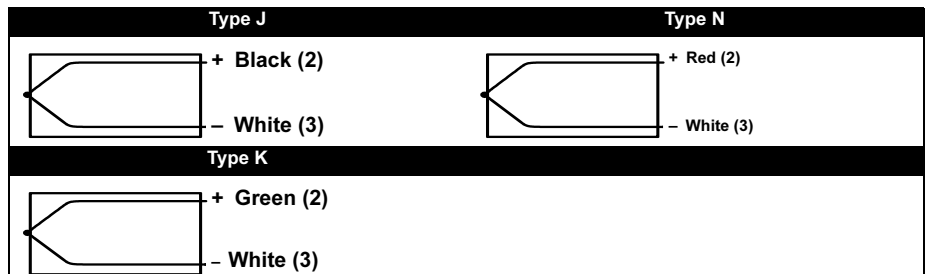

Figure 2-5. Rosemount 185 Thermocouple Lead Wire Configurations



Note:
Wire color examples apply to Emerson sensors, but will vary by manufacturer.

Examples of Approximate Lead Wire Resistance Effect Calculations

Given:

Total cable length	150 m
Imbalance of the lead wires at 20 °C	0.5 Ω
Resistance/length (18 AWG Cu):	0.025 Ω/m
Temperature coefficient of Cu (α_{Cu})	0.039 Ω/Ω °C
Temperature coefficient of Pt (α_{Pt})	0.00385 Ω/Ω °C
Change in Ambient Temperature (ΔT_{amb})	25 °C
RTD Resistance at 0 °C (R_0)	100 Ω (for Pt 100 RTD)

- **Pt100 4-wire RTD: No lead wire resistance effect**
- **Pt100 3-wire RTD:**

$$\text{Basic Error} = \frac{\text{Imbalance of Lead Wires}}{(\alpha_{Pt} \times R_0)}$$

$$\text{Error due to amb. temperature variation} = \frac{(\alpha_{Cu}) \times (\Delta T_{amb}) \times (\text{Imbalance of Lead Wires})}{(\alpha_{Pt} \times R_0)}$$

Lead wire imbalance seen by the transmitter = 0.5 Ω

$$\text{Basic Error} = \frac{0.5 \Omega}{(0.00385 \Omega / \Omega \text{ } ^\circ\text{C}) \times (100 \Omega)} = 1.3 \text{ } ^\circ\text{C}$$

$$\begin{aligned} \text{Error due to amb. temp. var. of } \pm 25 \text{ } ^\circ\text{C} &= \\ \frac{(0.0039 \Omega / \Omega \text{ } ^\circ\text{C}) \times (25 \text{ } ^\circ\text{C}) \times (0.5 \Omega)}{(0.00385 \Omega / \Omega \text{ } ^\circ\text{C}) \times (100 \Omega)} &= \pm 0.1266 \text{ } ^\circ\text{C} \end{aligned}$$

- **Pt100 2-wire RTD:**

$$\text{Basic Error} = \frac{\text{Imbalance of Lead Wires}}{(\alpha_{Pt} \times R_0)}$$

$$\text{Error due to amb. temp. variation} = \frac{(\alpha_{Cu}) \times (\Delta T_{amb}) \times (\text{Lead Wires Resistance})}{(\alpha_{Pt} \times R_0)}$$

Lead wire resistance seen by the transmitter = 150 m x 2 wires x 0.025 Ω/m = 7.5 Ω

$$\text{Basic Error} = \frac{7.5 \Omega}{(0.00385 \Omega / \Omega \text{ } ^\circ\text{C}) \times (100 \Omega)} = 19.5 \text{ } ^\circ\text{C}$$

$$\begin{aligned} \text{Error due to amb. temp. var. of } \pm 25 \text{ } ^\circ\text{C} &= \\ \frac{(0.0039 \Omega / \Omega \text{ } ^\circ\text{C}) \times (25 \text{ } ^\circ\text{C}) \times (7.5 \Omega)}{(0.00385 \Omega / \Omega \text{ } ^\circ\text{C}) \times (100 \Omega)} &= \pm 1.9 \text{ } ^\circ\text{C} \end{aligned}$$

Sensor Leads

 If the sensor is installed in a high-voltage environment and a fault condition or installation error occurs, the sensor leads and transmitter terminals could carry lethal voltages. Use extreme caution when making contact with the leads and terminals.

Use the following steps to wire the sensor and supply power to the transmitter:

1. Remove the transmitter enclosure cover (if applicable).
2. Attach the sensor leads according to the wiring diagrams.
3. Connect the battery.
4. Verify the connection by observing the LCD.
5. Reattach and tighten the cover (if applicable).

DEVICE SENSOR CONFIGURATION

Every temperature sensor has unique characteristics. In order to ensure the most accurate measurement, the Rosemount 648 should be configured to match the specific sensor that it will be connected to.

Begin by removing the battery-side housing cover. This will expose the terminal block and HART communication terminals. Connect the battery to supply power for configuration.

The Rosemount 648 will receive any HART communications from a handheld Field Communicator, or AMS. When using a Field Communicator, any configuration changes must be sent to the transmitter by using the **Send** key (F2). AMS configuration changes are implemented when the **Apply** button is clicked.

AMS Wireless and Direct Connections

AMS is capable of connecting to devices either directly, using a HART modem, or wirelessly via the 1420. When configuring on the bench using a HART modem, double click the device icon (or right click and select Configure/Setup), then choose the Configure/Setup tab. Configure the device settings using the Direct Connection menu. When configuring wirelessly via the 1420, double click the device icon (or right click and select Configure/Setup), then choose the Configure/Setup tab. Configure the device settings using the Wireless Connection menu.

To check or change sensor configuration using a 375 Field Communicator, enter the following Fast Key Sequence: 1, 3, 2, 1.

When the device configuration is 2 wire or 3 wire, terminal 4 of the device must be left disconnected. If connected, a configuration error may be indicated, which then prevents the device from providing process temperature measurements.

DEVICE NETWORK CONFIGURATION

In order to communicate with the 1420 Wireless Gateway, and ultimately the Information System, the transmitter must be configured to communicate with the wireless network. This step is the wireless equivalent of connecting wires from a transmitter to the information system.

Using a Field Communicator or AMS, enter the Network ID and Join Key so that they match the Network ID and Join Key of the gateway and other devices in the network. If the Network ID and Join Key are not identical, the transmitter will not communicate with the network. The Network ID and Join Key may be obtained from the 1420 Wireless Gateway on the **Setup>Network>Settings** page on the web server.

The final device network configuration piece is the Update Rate. This by default is 5 minutes. This may be changed at commissioning, or at any time via AMS or the 1420 Wireless Gateway's web server. The Update Rate should be between 15 seconds and 60 minutes. For networks of up to 100 wireless devices, fastest Update Rate is 60 seconds. For networks of 50 or fewer devices, the fastest Update Rate is 15 seconds

When device configuration is completed, remove the battery and replace the battery cover. Tighten the cover to the proper tension for safety approvals.

To access the Network Settings using a 375 Field Communicator, enter the following Fast Key Sequence: 1, 3, 3.

Figure 2-6. 648 Terminal Block

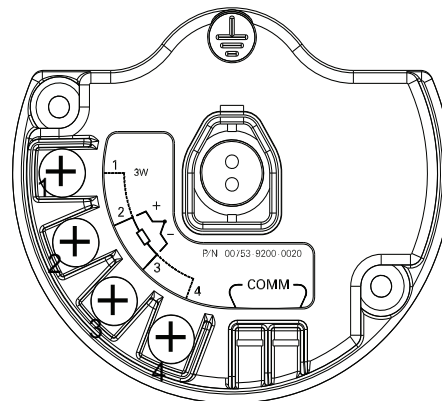

Connect the HART communication leads to the COMM terminals on the terminal block.

Figure 2-7. 375 Field Communicator Connections

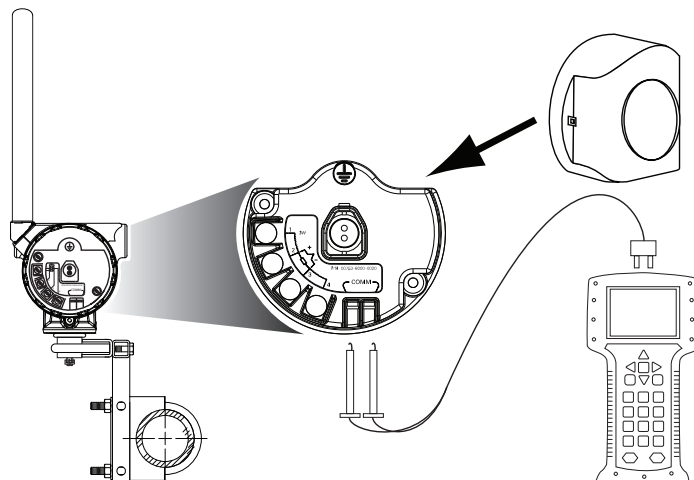

For HART communication, a 648 DD is required.

HART Menu Tree

Options listed in bold type indicate that a selection provides other options. For ease of operation, changing calibration and setup, such as sensor type, number of wires, and range values, can be completed in several locations.

Figure 2-8. Field Communicator Menu Tree

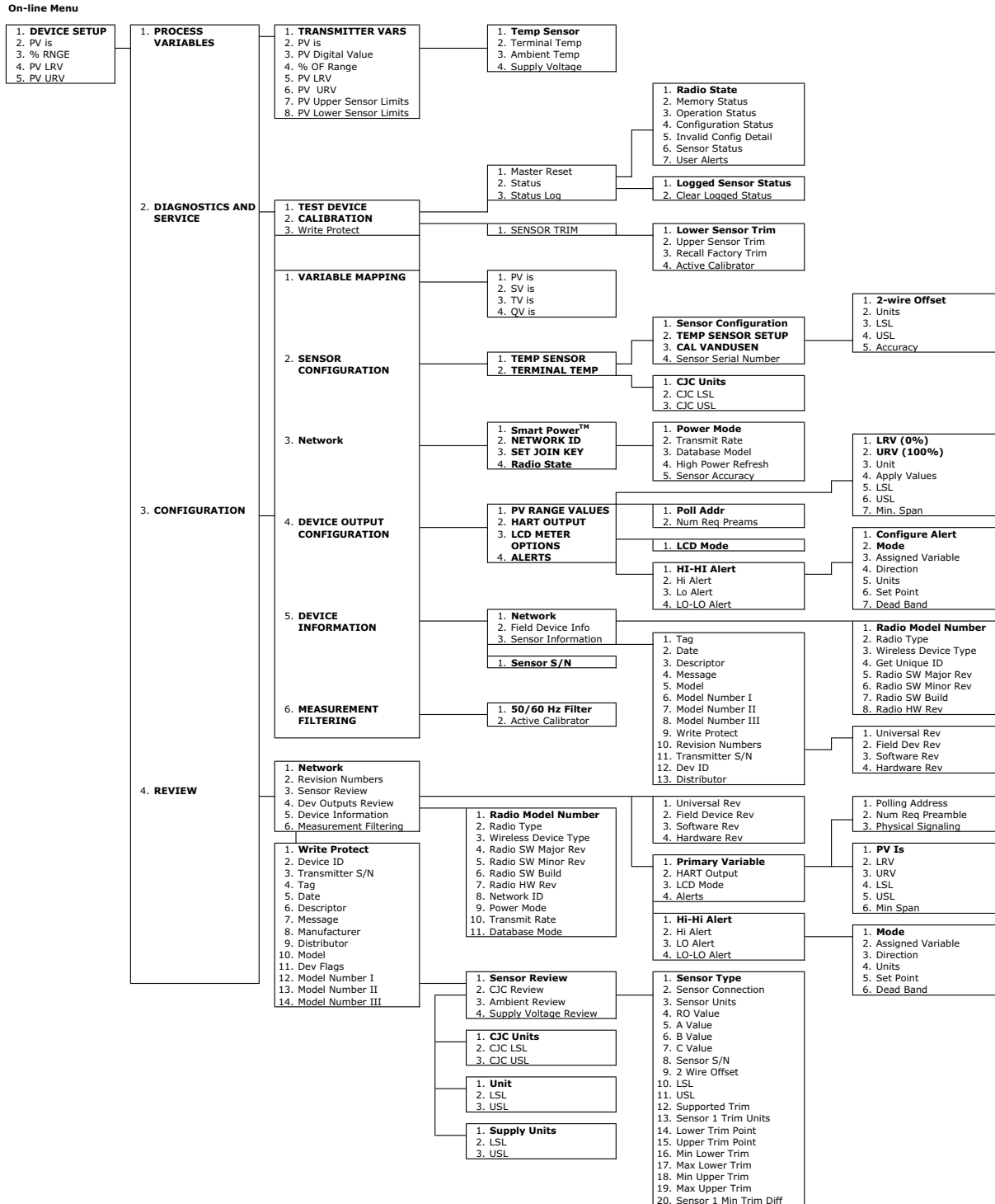

Fast Key Sequence

Table 2-2 lists the fast key sequences for common transmitter functions.

NOTE:

The fast key sequences assume that DD Dev v1, DD v4 is being used.

Table 2-2. 648 Fast Key Sequence

Function	Key Sequence	Menu Items
Device Information	1, 3, 5	Network, Field Device Info, Sensor Information
PV Range Values	1, 3, 4, 1	PV LRV, PV URV, PV Units, Apply Values, PV LSL, PV USL, PV Minimum Span
LRV (0%)	1, 3, 4, 1, 1	Sets the temperature for the 0% point to configure the Percent of Range
URV (100%)	1, 3, 4, 1, 2	Sets the temperature for the 100% point to configure the Percent of Range
Sensor Trim	1, 2, 2, 1	Lower Sensor Trim, Upper Sensor Trim, Sensor Trim-Fact, Active Calibrator
Network	1, 3, 3	Smart Power™, Network ID, Set Join Key, Radio State
Sensor Configuration	1, 3, 2, 1	Sensor Configuration, Temp Sensor Setup, Cal VanDusen, Sensor S/N

Calibration

Calibrating the transmitter increases the measurement precision by allowing corrections to be made to the factory-stored characterization curve by digitally altering the transmitter’s interpretation of the sensor input.

To understand calibration, it is necessary to understand that smart transmitters operate differently from analog transmitters. An important difference is that smart transmitters are factory-characterized, meaning that they are shipped with a standard sensor curve stored in the transmitter firmware. In operation, the transmitter uses this information to produce a process variable output, in engineering units, dependent on the sensor input.

Calibration of the 648 may include the following procedures:

- Sensor Input Trim: digitally alter the transmitter’s interpretation of the input signal
- Transmitter Sensor Matching: generates a special custom curve to match that specific sensor curve, as derived from the Callendar-Van Dusen constants

Trim the Transmitter

One or more of the trim functions may be used when calibrating. The trim functions are as follows:

- Sensor Input Trim
- Transmitter Sensor Matching

Sensor Input Trim

Fast Key Sequence	1, 2, 2, 1
-------------------	------------

Perform a sensor trim if the transmitters digital value for the primary variable does not match the plant's standard calibration equipment. The sensor trim function calibrates the sensor to the transmitter in temperature units or raw units. Unless your site-standard input source is NIST-traceable, the trim functions will not maintain the NIST-traceability of the system.

The *Sensor Input Trim* command allows the transmitter's interpretation of the input signal to be digitally altered. The sensor reference command trims, in engineering ($^{\circ}\text{F}$, $^{\circ}\text{C}$, $^{\circ}\text{R}$, K) or raw (Ω , mV) units, the combined sensor and transmitter system to a site standard using a known temperature source. Sensor trimming is suitable for validation procedures or for applications that require calibrating the sensor and transmitter together.

Use the following procedure to perform a sensor trim with a 648:

1. Connect the calibration device or sensor to the transmitter. Refer to Figure 2-1 on page 2-3 or on the device terminal block for sensor wiring diagrams.
2. Connect the communicator to the transmitter.
3. From the Home screen, select *1 Device Setup, 2 Diagnostics and Service, 2 Calibration, 1 Sensor Trim* to prepare to trim the sensor.
4. Select *1 Lower Sensor Trim* or *2 Upper Sensor Trim*. (Note: It is recommended to perform lower offset trims first, before performing upper slope trims).
5. Answer the question about using an active calibrator or not.
6. Adjust the calibration device to the desired trim value (must be within the selected sensor limits). If a combined sensor and transmitter system are being trimmed, expose the sensor to a known temperature and allow the temperature reading to stabilize. Use a bath, furnace or isothermal block, measured with a site-standard thermometer, as the known temperature source.
7. Select **OK** once the temperature stabilizes. The communicator displays the output value the transmitter associates with the input value provided by the calibration device.
8. Select the appropriate sensor trim units at the prompt.
9. Enter the trim point.

AMS

For AMS, configure the sensor as indicated above.

Right click on the device and select "Methods>Calibrate>Sensor Calibration" from the menu. Select "Lower Input Trim" or "Upper Limit Trim."

The *wizard* will continue through the process.

The transmitter may be restored to the factory default by selecting: "Methods>Calibrate>Sensor Calibration>Revert to Factory Trim."

The *wizard* will recall the factory trim for a given sensor.

Apply changes

Transmitter-Sensor Matching

Perform the *Transmitter Sensor Matching* procedure to enhance the temperature measurement accuracy of the system (see the comparison below) and if you have a sensor with Callendar-Van Dusen constants. When ordered from Emerson Process Management, sensors with Callendar-Van Dusen constants are NIST-traceable.

The 648 accepts Callendar-Van Dusen constants from a calibrated RTD schedule and generates the actual curve to match that specific sensor curve.

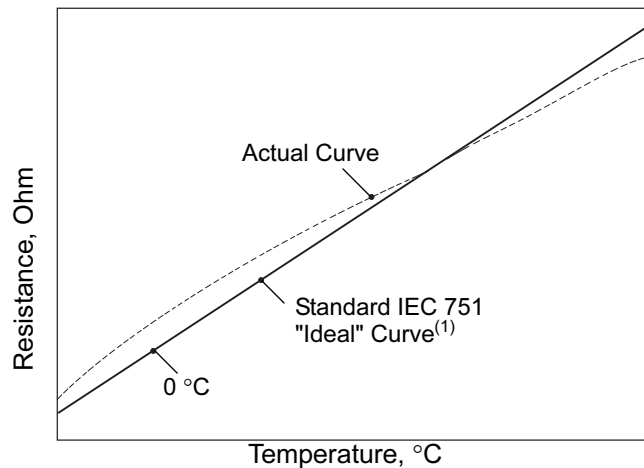

(1) The Actual Curve is identified from the Callendar-Van Dusen equation.

System Accuracy Comparison at 150 °C Using a PT 100 (A=0.00385) RTD with a Span of 0 to 200 °C			
Standard RTD		Matched RTD	
648	±0.45 °C	648	±0.45 °C
Standard RTD	±1.05 °C	Matched RTD	±0.018°C
Total System ⁽¹⁾	±1.14 °C	Total System ⁽¹⁾	±0.048 °C

(1) Calculated using root-summed-squared (RSS) statistical method.

$$\text{Total System Accuracy} = \sqrt{(\text{Transmitter Accuracy})^2 + (\text{Sensor Accuracy})^2}$$

Callendar-Van Dusen equation:

$$R_t = R_o + R_{o\alpha} [t - \delta(0.01t-1)(0.01t) - \beta(0.01t - 1)(0.01t)^3]$$

The following input variables, included with specially-ordered Rosemount temperature sensors, are required:

- R_o = Resistance at Ice Point
- Alpha = Sensor Specific Constant
- Beta = Sensor Specific Constant
- Delta = Sensor Specific Constant

To input Callendar-Van Dusen constants, perform the following procedure:

1. From the **HOME** screen, select *1 Device Setup, 3 Configuration, 2 Sensor Configuration, 1 Temp Sensor, 1 Sensor Configuration*.
2. Select *Cal VanDusen* at the **ENTER SENSOR TYPE** prompt.
3. Select the appropriate number of wires at the **ENTER SENSOR CONNECTION** prompt.
4. Enter the R_0 , Alpha, Delta, and Beta values from the stainless steel tag attached to the special-order sensor when prompted.

To disable the transmitter-sensor matching feature from the **HOME** screen select *1 Device Setup, 3 Configuration, 2 Sensor Configuration, 1 Temp Sensor, 1 Sensor Configuration*. Choose the appropriate sensor type from the **ENTER SENSOR TYPE** prompt.

NOTE

When the transmitter-sensor matching is disabled, the transmitter reverts to factory trim. Make certain the transmitter engineering units default correctly before placing the transmitter into service.

Alerts

Fast Keys	1, 3, 4, 4
-----------	------------

Alerts allow the user to configure the transmitter to output a HART message when the configured data point is exceeded. A process alert will be transmitter continuously if the set points are exceeded and the alert mode is **ON**. An alert will be displayed on a Field Communicator, AMS status screen or in the error section of the LCD display. The alert will reset once the value returns within range.

NOTE

HI alert value must be higher than the LO alert value. Both alert values must be within the temperature sensor limits.

Example 1: Rising Alert

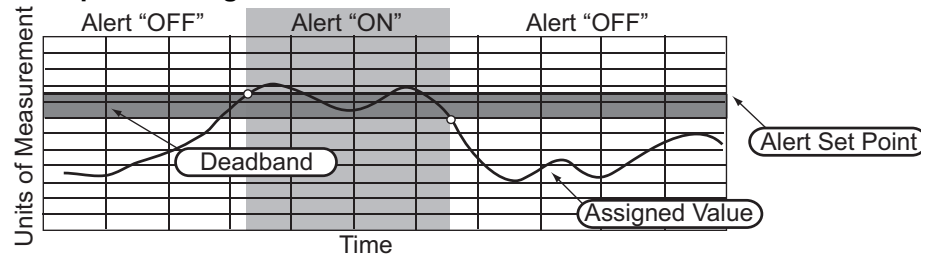

Example 2: Falling Alert

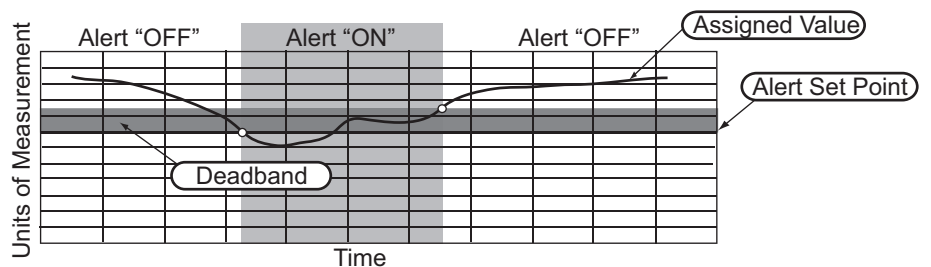

Field Communicator

To configure the process alerts with a Field Communicator, perform the following procedure:

1. From the **HOME** screen, follow the fast key sequence “Alerts” (1 Device Setup, 3 Configuration, 4 Device Output Configuration, 4 Alerts).
2. Select 1 for HI-HI Alert.
Select 2 for HI Alert
Select 3 for LO Alert
Select 4 for LO-LO Alert
3. Select 1 to configure the alert.

AMS

Right click on the device and select “Configure/Setup” from the menu.

1. On the “Alerts” Page, press the “Configure Alert” button for each of the process alerts desires (1 per tab). Follow the prompts from the alert configuration wizard.

REMOVE BATTERY

After the sensor and network have been configured, remove the battery pack and replace the transmitter cover. The battery pack should be inserted only when the device is ready to be commissioned.

Section 3 Mounting

Safety Messages	page 3-1
Mounting	page 3-2
Direct Mount	page 3-2
Remote Mount	page 3-4
LCD Display	page 3-5
Ground the Transmitter	page 3-5

SAFETY MESSAGES

Instructions and procedures in this section may require special precautions to ensure the safety of the personnel performing the operations. Information that potentially raises safety issues is indicated by a warning symbol (⚠). Please refer to the following safety messages before performing an operation preceded by this symbol.

Warnings

⚠ WARNING

Failure to follow these installation guidelines could result in death or serious injury.

- Make sure only qualified personnel perform the installation.

Explosions could result in death or serious injury.

- Before connecting a 375 Field Communicator in an explosive atmosphere, make sure the instruments are installed in accordance with intrinsically safe or non-incendive field wiring practices.
- Verify that the operating atmosphere of the transmitter is consistent with the appropriate hazardous locations certifications.

Process leaks could result in death or serious injury.

- Do not remove the thermowell while in operation.
- Install and tighten thermowells and sensors before applying pressure

Electrical shock could cause death or serious injury.

- Use extreme caution when making contact with the leads and terminals.

MOUNTING

The Rosemount 648 can be installed in one of two configurations: Direct Mount, where the sensor is connected directly to the 648 housing's conduit entry, or Remote Mount, where the sensor is mounted separate from the 648 housing, then connected to the 648 via conduit. Choose the installation sequence that corresponds to the mounting configuration.

Figure 3-1 provides an example of the relationship between transmitter housing temperature rise and extension length.

Figure 3-1. 648 Transmitter Connection Head Temperature Rise vs. Extension Length

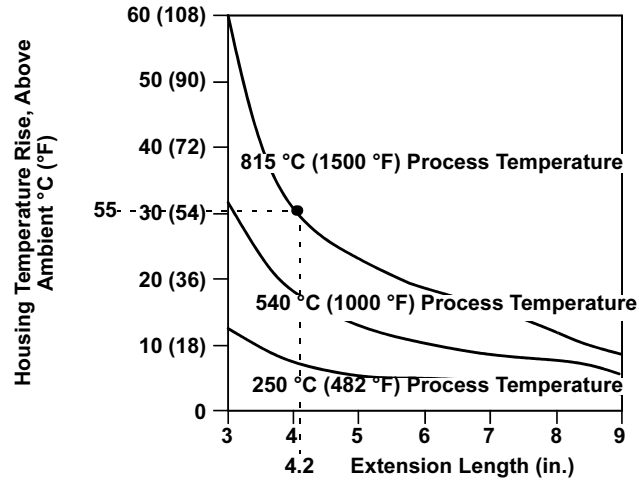

Example

The transmitter specification limit is 85 °C. If the ambient temperature is 55 °C and the max process temperature to be measured is 815 °C, the maximum permissible connection head temperature rise is the transmitter specification limit minus the ambient temperature (moves 85 to 55 °C), or 30 °C.

In this case, an extension of 5” meets this requirement, but 6” provides an additional margin of thermowell protection, thereby reducing risk of ambient thermal damage.

Direct Mount

The direct mount installation should not be used when installing with a Swagelok® fitting.

1. Install the sensor/thermocouple according to standard installation practices. Be sure to use thread sealant on all connections.
2. Attach the 648 housing to the sensor/thermocouple using the threaded conduit entry.
3. Attach the sensor/thermocouple wiring to the terminals as indicated on the wiring diagram.
4. Connect the battery pack if commissioning the device.

NOTE

Use caution when handling the battery pack. The battery pack may be damaged if dropped from heights in excess of 20 feet.

NOTE:

Wireless devices should be powered up after the 1420 Wireless Gateway and in order of proximity from the 1420, beginning with the closest device to the 1420. This will result in a simpler and faster network installation.

5. Close the housing cover and tighten to safety specification. Always ensure a proper seal by installing the electronics housing covers so that metal touches metal, but do not over tighten.
6. Position the antenna such that it is **vertical**, typically straight up (antenna may be pointed straight down as well).

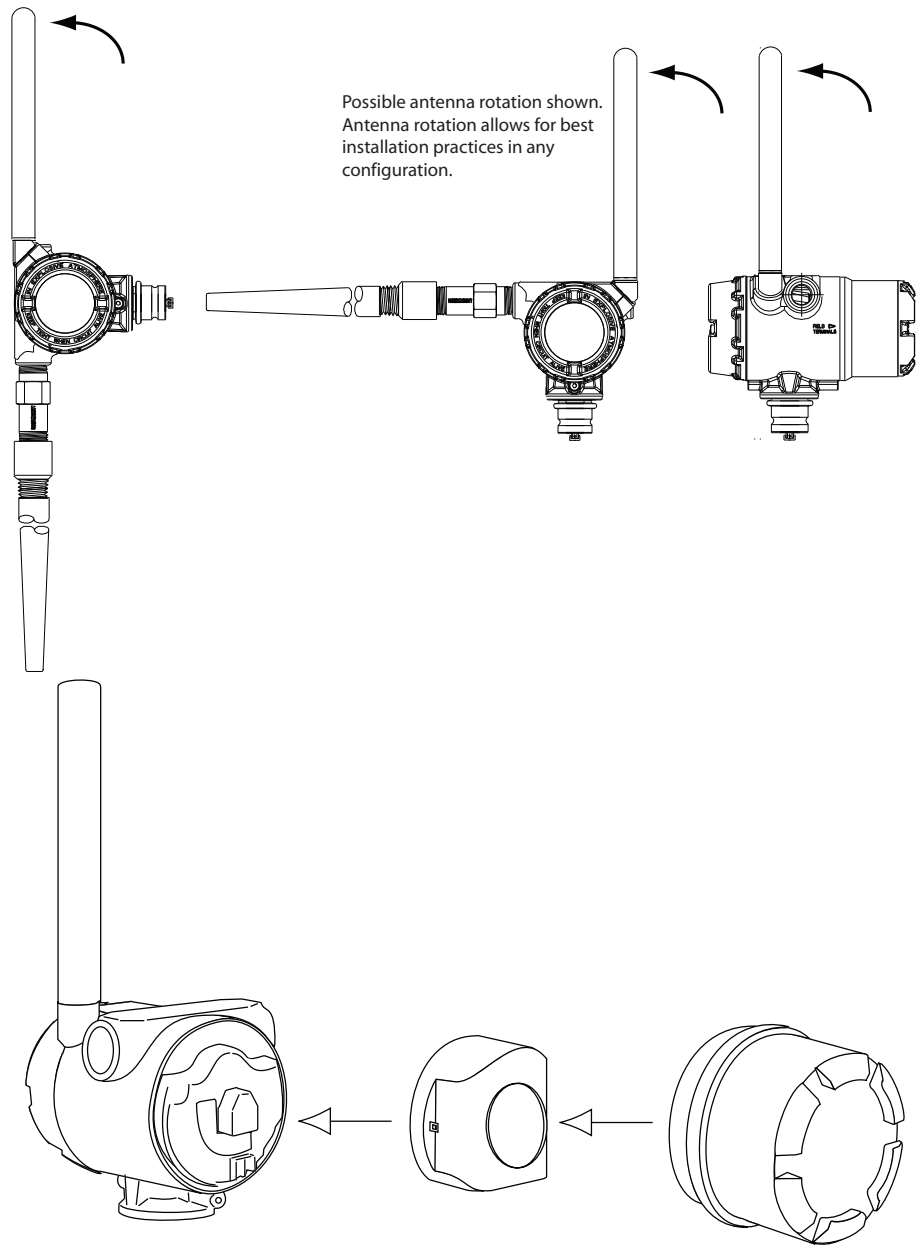

Remote Mount

1. Install the sensor/thermocouple according to standard installation practices. Be sure to use thread sealant on all connections.
2. Run wiring (and conduit if necessary) from the sensor/thermocouple to the 648.
3. Pull the wiring through the threaded conduit entry of the 648.
4. Attach the sensor/thermocouple wiring to the terminals as indicated on the wiring diagram.
5. Connect the battery pack if commissioning.

NOTE

Use caution when handling the battery pack. The battery pack may be damaged if dropped from heights in excess of 20 feet.

NOTE:

Wireless devices should be powered up after the 1420 Wireless Gateway and in order of proximity from the 1420, beginning with the closest device to the 1420. This will result in a simpler and faster network installation.

6. Close the housing cover and tighten to safety specification. Always ensure a proper seal by installing the electronics housing covers so that metal touches metal, but do not over tighten.
7. Position the antenna such that it is **vertical**, typically straight up (antenna may be pointed straight down as well).

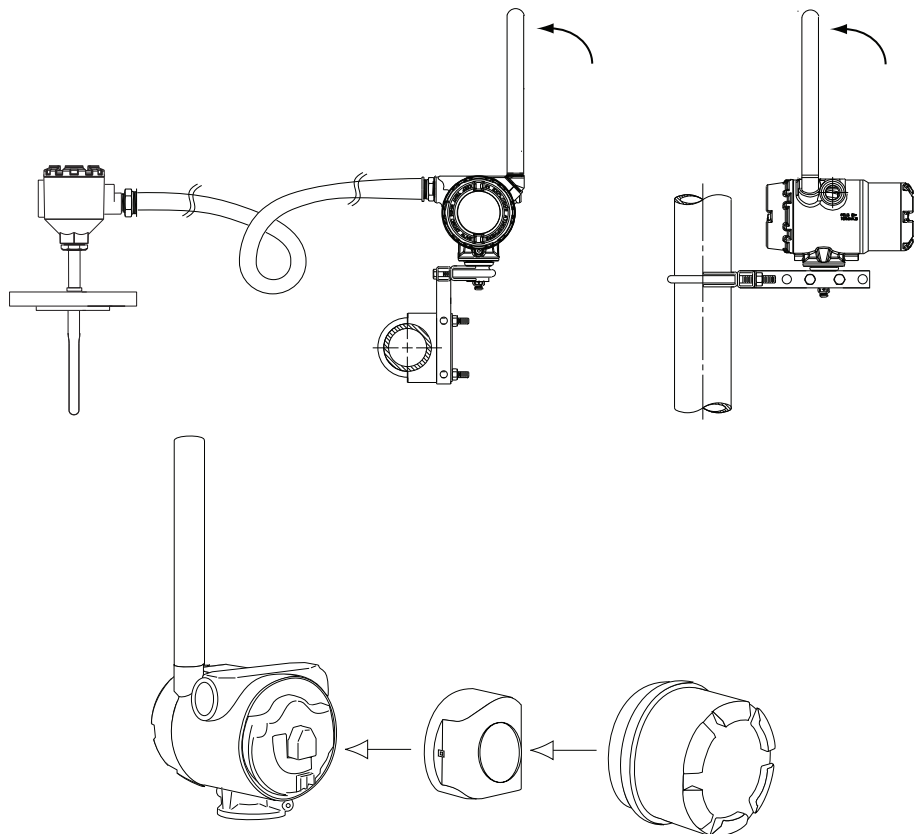

LCD Display

Transmitters ordered with the LCD display will be shipped with the display installed.

The optional LCD display can be rotated in 90-degree increments by squeezing the two tabs, pulling out, rotating and snapping back into place.

If LCD pins are inadvertently removed from the interface board, carefully re-insert the pins before snapping the LCD display back into place.

Use the following procedure and Figure 3-2 to install the LCD display:

1. Remove the LCD cover. Do not remove the instrument covers in explosive environments when the circuit is live.
2. Put the four-pin connector into the LCD display, rotate to the desired position and snap into place.

Note the following LCD temperature limits:

Operating: -4 to 175 °F (-20 to 80 °C)

Storage: -40 to 185 °F (-40 to 85 °C)

3. Replace the transmitter cover.

NOTE

Only use Rosemount Wireless LCD Part Number: 00753-9004-0002.

Figure 3-2. Optional LCD Display

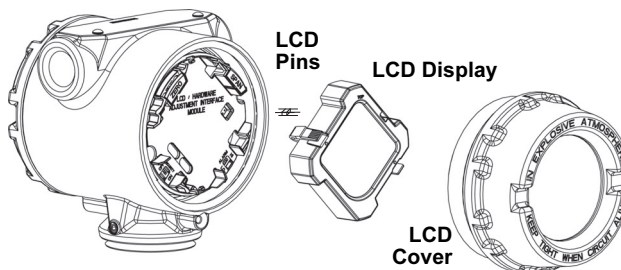

Ground the Transmitter

The transmitter will operate with the housing either floating or grounded. However, the extra noise in floating systems affects many types of readout devices. If the signal appears noisy or erratic, grounding the transmitter at a single point may solve the problem.

The electronics enclosure should be grounded in accordance with local and national installation codes. This can be accomplished via the process connection, via the internal case grounding terminal, or via the external grounding terminal.

Thermocouple, mV, and RTD/Ohm Inputs

Each process installation has different requirements for grounding. Use the grounding options recommended by the facility for the specific sensor type, or begin with grounding Option 1 (the most common).

Option 1:

1. Connect sensor wiring shield to the transmitter housing (only if the housing is grounded).
2. Ensure the transmitter housing is electrically isolated from the sensor wiring.

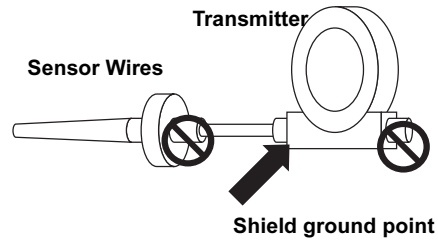

Option 2:

1. Ground sensor wiring shield at the sensor.
2. Ensure that the sensor wiring and shield is electrically isolated from the transmitter housing.

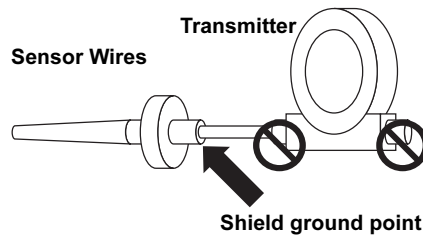

NOTE:

Always use facility recommended wiring practices.

Section 4 Commissioning

Safety Messages	page 4-1
Verify Operation	page 4-2

SAFETY MESSAGES

Instructions and procedures in this section may require special precautions to ensure the safety of the personnel performing the operations. Information that potentially raises safety issues is indicated by a warning symbol (⚠). Please refer to the following safety messages before performing an operation preceded by this symbol.

Warnings

⚠ WARNING

Failure to follow these installation guidelines could result in death or serious injury.

- Make sure only qualified personnel perform the installation.

Explosions could result in death or serious injury.

- Before connecting a 375 Field Communicator in an explosive atmosphere, make sure the instruments are installed in accordance with intrinsically safe or non-incendive field wiring practices.
- Verify that the operating atmosphere of the transmitter is consistent with the appropriate hazardous locations certifications.

Process leaks could result in death or serious injury.

- Do not remove the thermowell while in operation.
- Install and tighten thermowells and sensors before applying pressure

Electrical shock could cause death or serious injury.

- Use extreme caution when making contact with the leads and terminals.

NOTE

The Rosemount 648 and all other wireless devices should be installed only after the 1420 Wireless Gateway has been installed and is functioning properly. Wireless devices should also be powered up in order of proximity from the 1420 Wireless Gateway, beginning with the closest device to the 1420. This will result in a simpler and faster network installation.

VERIFY OPERATION

Operation can be verified in three locations, at the device via the Local Display, using the 375 Field Communicator, or at the Gateway via the 1420 Wireless Gateway’s integrated web server.

Local Display

During normal operation, the LCD will display the PV value at the wireless transmit rate up to as fast as 1 minute intervals. Refer to LCD Screen Messages on page 5-2 for error codes and other LCD messages. Press the **Diagnostic** button to display the **TAG, Device ID, Network ID, Network Join Status** and **Device Status** screens. For Device Status screens, see LCD Screen Messages on page 5-2

Figure 4-1. Diagnostic Screen Sequence

Tag	Device ID	Network ID	Network Status	Device Variables

Figure 4-2. Network Status Screens

Searching for Network	Joining Network	Connected with 1 Parent	Connected with 2 Parents

375 Field Communicator

To verify device operation using a HART Field Communicator, a 648 DD is required.

Function	Key Sequence	Menu Items
Network	1, 3, 3	Smart Power, Network ID, Set Join Key, Radio State

1420 Wireless Gateway

To verify device operation using the 1420 Wireless Gateway’s integrated web server, navigate to the **Explorer>Status** page. This page will show whether the device has joined the network and if it is communicating properly.

If the Rosemount 648 was configured with the Network ID and Join Key and sufficient time for network polling has passed, the transmitter will be connected to the network. To verify connectivity, open the 1420 Wireless Gateway's integral web interface and navigate to the **Explorer>Status** page.

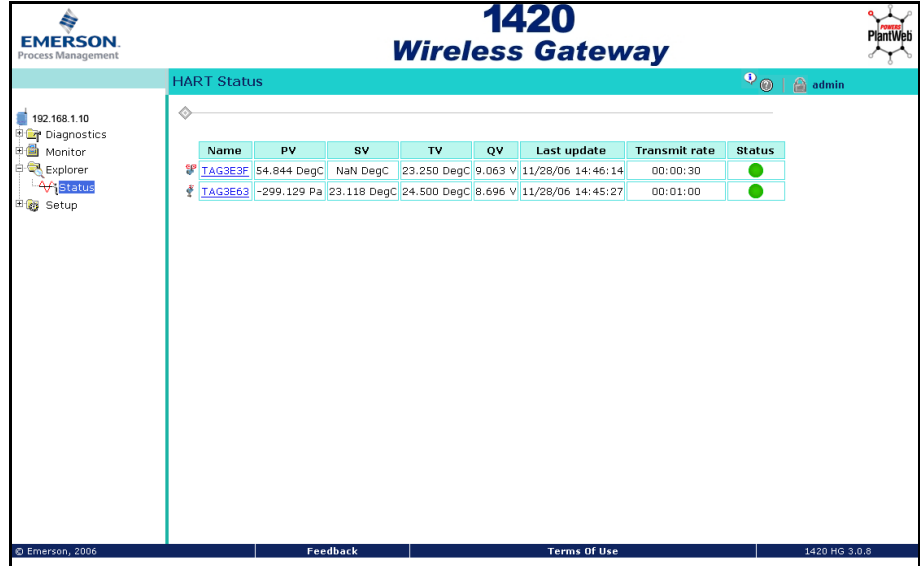

This page will display the transmitter's tag, PV, SV, TV, QV, Last Update, Update Rate, Battery Voltage, and Status. A green status indicator means that the device is working properly. A red indicator means that there is a problem with either the device or its communication path. For more detail on a specific device, click on the tag name.

Troubleshooting

The most common cause of incorrect operation is the Network ID and Join Key. The Network ID and Join Key in the device must match that of the 1420 Wireless Gateway. The Network ID and Join Key may be obtained from the 1420 Wireless Gateway on the **Setup>Network>Settings** page on the web server.

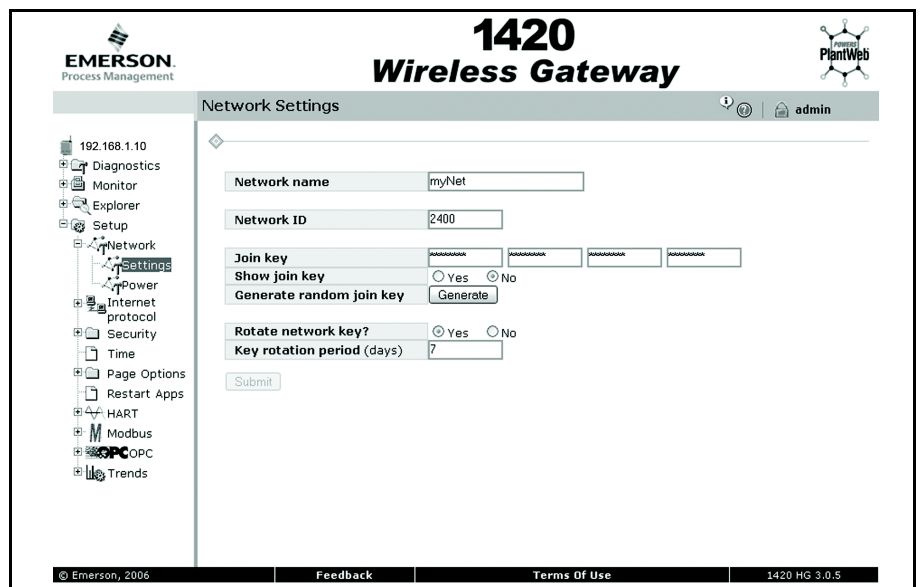

Section 5 Operation and Maintenance

Safety Messages	page 5-1
LCD Screen Messages	page 5-2
Battery Replacement	page 5-9

SAFETY MESSAGES

Instructions and procedures in this section may require special precautions to ensure the safety of the personnel performing the operations. Information that potentially raises safety issues is indicated by a warning symbol (⚠). Please refer to the following safety messages before performing an operation preceded by this symbol.

Warnings

⚠ WARNING
<p>Failure to follow these installation guidelines could result in death or serious injury.</p> <ul style="list-style-type: none">• Make sure only qualified personnel perform the installation.
<p>Explosions could result in death or serious injury.</p> <ul style="list-style-type: none">• Before connecting a 375 Field Communicator in an explosive atmosphere, make sure the instruments are installed in accordance with intrinsically safe or non-incendive field wiring practices.• Verify that the operating atmosphere of the transmitter is consistent with the appropriate hazardous locations certifications.
<p>Process leaks could result in death or serious injury.</p> <ul style="list-style-type: none">• Do not remove the thermowell while in operation.• Install and tighten thermowells and sensors before applying pressure
<p>Electrical shock could cause death or serious injury.</p> <ul style="list-style-type: none">• Use extreme caution when making contact with the leads and terminals.

Rosemount 648

LCD SCREEN MESSAGES

Startup Screen Sequence

The following screens will display when the battery is first connected to the Rosemount 648.

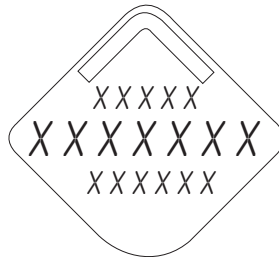

All Segments On: used to visually determine if there are any bad segments on the LCD

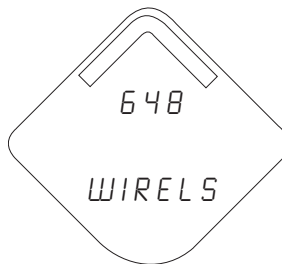

Device Identification: used to determine Device Type.

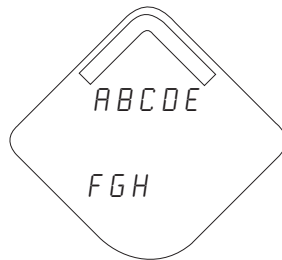

Device Information - Tag: user entered tag which is 8 characters long - will not display if all characters are blank



PV Screen - process temperature, ohms or mV value depending on how the device is configured

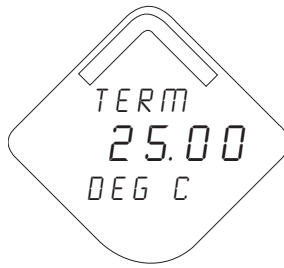

SV Screen - terminal temperature value



TV Screen - feature board temperature value

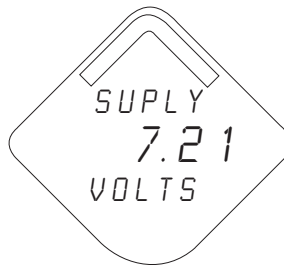

QV Screen - voltage reading at the power supply terminals



Alert Screen - at least one alert is present - this screen will not display if no alerts are present

Diagnostic Button Screen Sequence

The following five screens will display when the device is operating properly and the Diagnostic Button has been pressed.

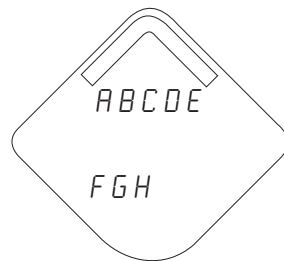

Device Information - Tag: user entered tag which is 8 characters long - will not display if all characters are blank

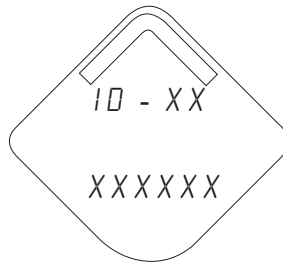

Device Identification: used to determine Device ID

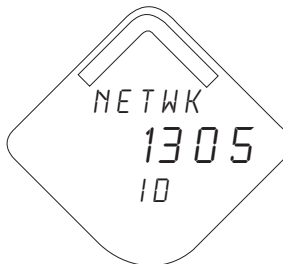

Diagnostic Button Screen 3: assuming the device has the correct join key, this ID tells the user what network the device can connect with

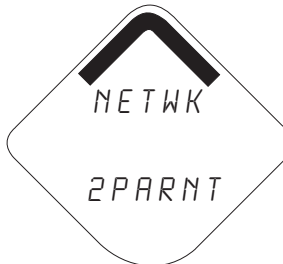

Diagnostic Button Screen 4.11: the device has joined a network and has been fully configured and has multiple parents

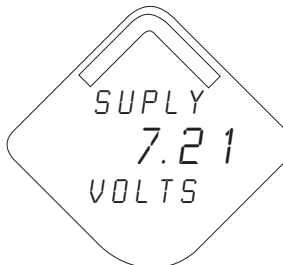

Diagnostic Button Screen 5: voltage reading at the power supply terminals

Network Diagnostic Status Screens

These screens display the network status of the device. Only one will be shown during the startup sequence or diagnostic sequence.

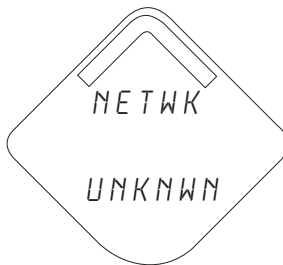

Diagnostic Button Screen 4.1: the device has yet to retrieve the information from the 1420 and is still in the process of being activated



Diagnostic Button Screen 4.2: the device has received the ACTIVATE command from the 1420, but is in the process of being configured to the wireless network

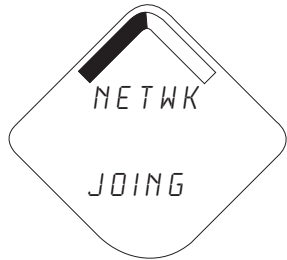

Diagnostic Button Screen 4.3: the device has sent JOIN request and is waiting for the ACTIVATE command

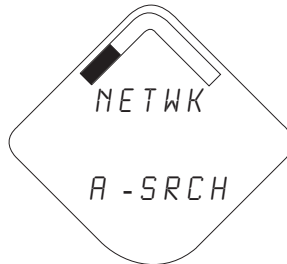

Diagnostic Button Screen 4.4: the device is in active search

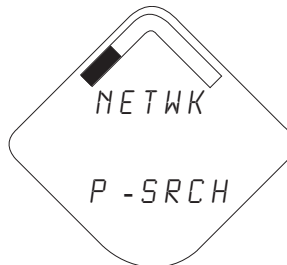

Diagnostic Button Screen 4.5: the device is in passive search

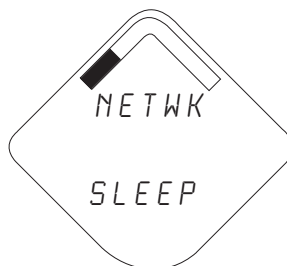

Diagnostic Button Screen 4.6: the device couldn't find the network and is in deep sleep mode to preserve battery power

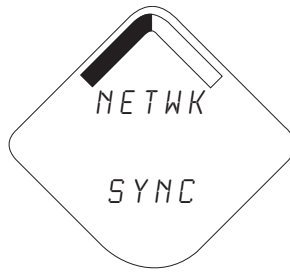

Diagnostic Button Screen 4.7: the device synchronized to a network

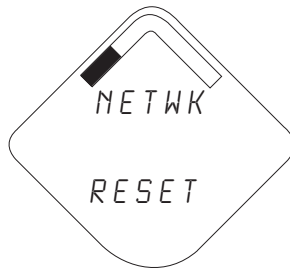

Diagnostic Button Screen 4.8: the device will reset

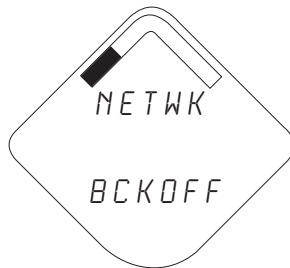

Diagnostic Button Screen 4.9: the device couldn't join because of dropped packets and will reset

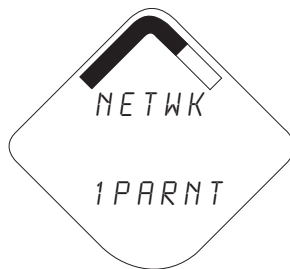

Diagnostic Button Screen 4.10: the device has joined a network and has been fully configured but has only 1 parent device

Device Diagnostic Screens

The following screens will show the device diagnostics depending on the state of the device.

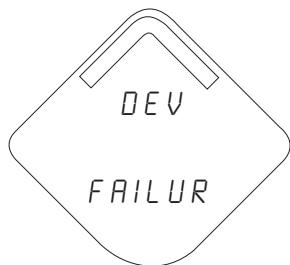

Device Information - Status: there is a critical error which may prevent the device from operating correctly. Check additional status screens for more information.

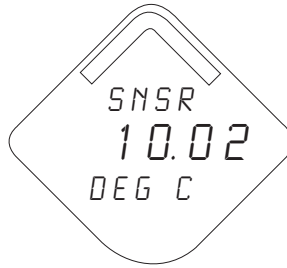

PV Screen - process temperature, ohms or mV value depending on how the device is configured

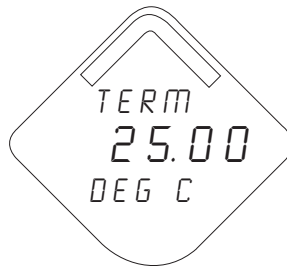

SV Screen - terminal temperature value

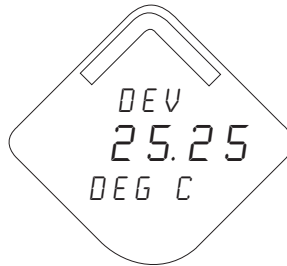

TV Screen - feature board temperature value

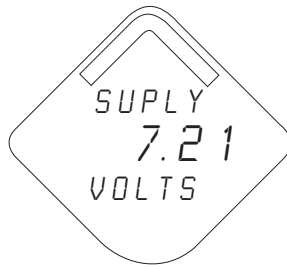

QV Screen - voltage reading at the power supply terminals

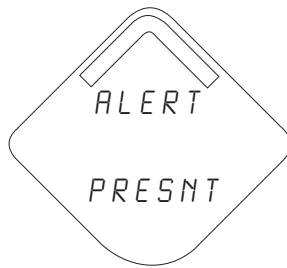

Alert Screen - at least one alert is present - this screen will not display if no alerts are present

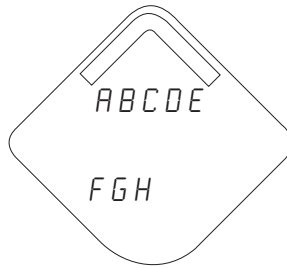

Diagnostic Button Screen 1 - Tag: user entered tag which is 8 characters long - will not display if all characters are blank

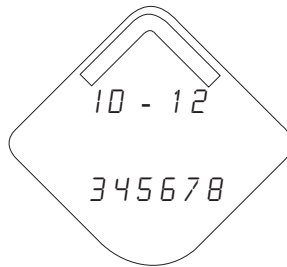

Diagnostic Button Screen 2: the device's identifier that is used to make up the HART long address - the 1420 Wireless Gateway may use this to help identify devices if no unique user tag is available

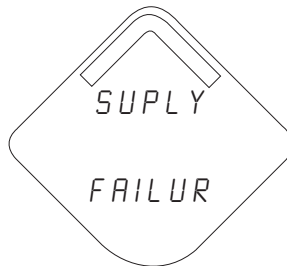

Diagnostic Button Screen 7.1: the terminal voltage has dropped below level of operating limit. Replace the battery (Part Number: 00753-9220-XXXX)

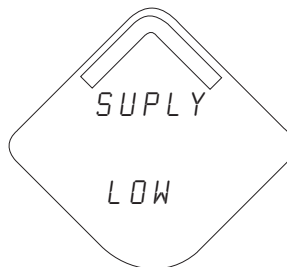

Diagnostic Button Screen 7.2: the terminal voltage is below the recommended operating range - if this is a battery operated device, the battery should be replaced - for line powered devices, the supply voltage should be increased



Diagnostic Button Screen 8: the device cannot retrieve information from the radio in the device - the device may still be operational and publishing HART data

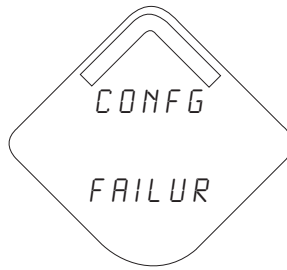

Diagnostic Button Screen 9.1: configuration of the transmitter is invalid such that critical operation of the device may be affected - check the extended configuration status to identify which configuration item(s) need to be corrected

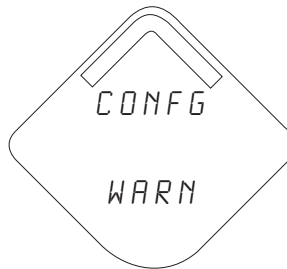

Diagnostic Button Screen 9.2: configuration of the transmitter is invalid such that non-critical operation of the device may be affected - check the extended configuration status to identify which configuration item(s) need to be corrected

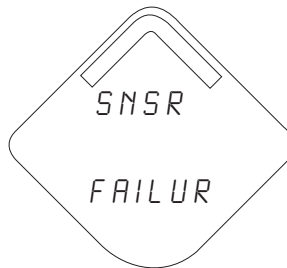

Diagnostic Button Screen 10.1: a sensor attached to the transmitter has failed, and valid readings from that sensor are no longer possible - check the sensor and sensor wiring connections - check additional status for more detailed information of the failure source

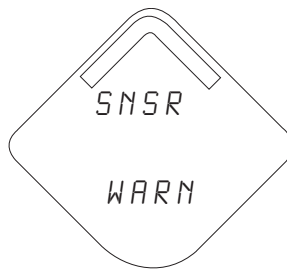

Diagnostic Button Screen 10.2: a sensor attached to the transmitter is degraded, readings from that sensor may not be within accuracy specifications - check the process, and sensor wiring connections - check additional status for more detailed information of the warning source

NOTE

Use the Rosemount Wireless LCD Part Number: 00753-9004-0002.

**BATTERY
REPLACEMENT**

Expected battery life is eight years at reference conditions.⁽¹⁾

When battery replacement is required, remove the battery cover and remove the battery pack. Replace the pack (part number 00753-9220-XXXX) and replace the cover. Tighten to specification and verify operation.

(1) Reference conditions are 70° F (21° C), transmit rate of once per minute, and routing data for three additional network devices.

Handling Considerations

The battery pack with the wireless unit contains 2 “C” size primary lithium/thionyl chloride batteries. Each battery contains approximately 2.5 grams of lithium, for a total of 5 grams in each pack. Under normal conditions, the battery materials are self-contained and are not reactive as long as the batteries and the battery pack integrity are maintained. Care should be taken to prevent thermal, electrical or mechanical damage. Contacts should be protected to prevent premature discharge.

Use caution when handling the battery pack. The battery pack may be damaged if dropped from heights in excess of 20 feet.

 Battery hazards remain when cells are discharged.

Environmental Considerations

As with any battery, local environmental rules and regulations should be consulted for proper management of spent batteries. If no specific requirements exist, recycling through a qualified recycler is encouraged. Consult the materials safety data sheet for battery specific information.

Shipping Considerations

The unit is shipped to you without the battery installed. Unless specifically instructed to do otherwise, remove the battery pack from the unit prior to shipping.

Primary lithium batteries are regulated in transportation by the U.S. Department of Transportation, and are also covered by International Air Transport Association (IATA), International Civil Aviation Organization (ICAO), and European Ground Transportation of Dangerous Goods (ARD). It is the responsibility of the shipper to ensure compliance with these or any other local requirements. Please consult current regulations and requirements before shipping.

Appendix A Specifications and Reference Data

Specifications	page A-1
Dimensional Drawings	page A-5
Ordering Information	page A-6

SPECIFICATIONS

Functional Specifications

Input

Supports Thermocouple, RTD, millivolt and ohm input types. See Accuracy on page A-3 for sensor options.

Output

Wireless enabled, linear with temperature or input.

Local Display

The optional five-digit integral LCD Display can display engineering units (°F, °C, °R, K, Ω, and millivolts). Display updates at transmit rate up to once per minute.

Humidity Limits

0–100% relative humidity

Transmit Rate

User selectable, 15 sec. to 60 min.

Accuracy

(PT 100 @ reference conditions: 20 °C)
±0.45 °C (±0.81 °F)

Physical Specifications

Electrical Connections / Battery

- Replaceable, non-rechargeable, Intrinsically Safe Lithium-Thionyl Chloride battery pack with PBT enclosure.
- Eight year battery life at reference conditions.⁽¹⁾
- 4 Screw Terminals for sensor connection.

Field Communicator Connections

Communication Terminals

Clips permanently fixed to terminal block

⁽¹⁾ Reference conditions are 70° F (21° C), transmit rate of once per minute, and routing data for three additional network devices.

Materials of Construction

Enclosure

Housing

- Low-copper aluminum

Paint

- Polyurethane

Cover O-ring

- Buna-N

Terminal Block and Battery Pack

- PBT

Antenna

- PBT/PC integrated omnidirectional antenna

Mounting

Transmitters may be attached directly to the sensor. Mounting brackets also permit remote mounting. See "Dimensional Drawings" on page A-5.

Weight

648 without LCD - 4.6 lbs. (2 kg)

648 with M5 LCD - 4.7 lbs (2.1 kg)

Enclosure Ratings (648)

Housing option code D is NEMA 4X, and IP66.

Performance Specifications

EMC (ElectroMagnetic Compatibility)

The 648 meets all requirements listed under IEC 61326.

Transmitter Stability

The 648 has a stability of $\pm 0.3\%$ of output reading or $0.3\text{ }^{\circ}\text{C}$ (whichever is greater) for 24 months

Self Calibration

The analog-to-digital measurement circuitry automatically self-calibrates for each temperature update by comparing the dynamic measurement to extremely stable and accurate internal reference elements.

Vibration Effect

Less than $\pm 0.1\%$ of URL when tested per the requirements of IEC60770-1 field with general application or pipeline with low vibration level (10-60 Hz 0.15 mm displacement peak amplitude/60-500 Hz 2g).

Accuracy

TABLE 1. Rosemount 648 Input Options and Accuracy.

Sensor Options	Sensor Reference	Input Ranges		Digital Accuracy ⁽¹⁾	
		°C	°F	°C	°F
2-, 3-, 4-wire RTDs					
Pt 50 ($\alpha = 0.003910$)	GOST 6651-94	-200 to 550	-328 to 990	± 0.9	± 1.62
Pt 100 ($\alpha = 0.00385$)	IEC 751, 1995 ($\alpha = 0.00385$)	-200 to 850	-328 to 1562	± 0.45	± 0.81
Pt 100 ($\alpha = 0.003910$)	GOST 6651-94	-200 to 550	-328 to 990	± 0.45	± 0.81
Pt 100 ($\alpha = 0.003916$)	JIS 1604, 1981 ($\alpha = 0.003916$)	-200 to 645	-328 to 1193	± 0.45	± 0.81
Pt 200 ($\alpha = 0.00385$)	IEC 751, 1995 ($\alpha = 0.00385$)	-200 to 850	-328 to 1562	± 0.81	± 1.458
Pt 200 ($\alpha = 0.003916$)	JIS 1604, 1981 ($\alpha = 0.003916$)	-200 to 645	-328 to 1193	± 0.81	± 1.458
Pt 500	IEC 751, 1995 ($\alpha = 0.00385$)	-200 to 850	-328 to 1562	± 0.57	± 1.026
Pt 1000	IEC 751, 1995 ($\alpha = 0.00385$)	-200 to 300	-328 to 572	± 0.57	± 1.026
Ni 120	Edison Curve No. 7	-70 to 300	-94 to 572	± 0.45	± 0.81
Cu 10	Edison Copper Winding No. 15	-50 to 250	-58 to 482	± 4.16	± 7.488
Cu 50 ($\alpha = 426$)	GOST 6651-94	-50 to 200	-122 to 392	± 1.44	± 2.592
Cu 50 ($\alpha = 428$)	GOST 6651-94	-185 to 200	-365 to 392	± 1.44	± 2.592
Cu 100 ($\alpha = 426$)	GOST 6651-94	-50 to 200	-122 to 392	± 0.72	± 1.296
Cu 100 ($\alpha = 428$)	GOST 6651-94	-185 to 200	-365 to 392	± 0.72	± 1.296
Thermocouples⁽²⁾					
Type B ⁽³⁾	NIST Monograph 175, IEC 584	100 to 1820	212 to 3308	± 2.25	± 4.05
Type E	NIST Monograph 175, IEC 584	-50 to 1000	-58 to 1832	± 0.60	± 1.08
Type J	NIST Monograph 175, IEC 584	-180 to 760	-292 to 1400	± 1.05	± 1.89
Type K ⁽⁴⁾	NIST Monograph 175, IEC 584	-180 to 1372	-292 to 2502	± 1.46	± 2.628
Type N	NIST Monograph 175, IEC 584	-200 to 1300	-328 to 2372	± 1.46	± 2.628
Type R	NIST Monograph 175, IEC 584	0 to 1768	32 to 3214	± 2.25	± 4.05
Type S	NIST Monograph 175, IEC 584	0 to 1768	32 to 3214	± 2.1	± 3.78
Type T	NIST Monograph 175, IEC 584	-200 to 400	-328 to 752	± 1.05	± 1.89
GOST L	GOST R 8.585-2001	-200 to 800	-392 to 1472	± 1.80	± 3.24
DIN Type L	DIN 43710	-200 to 900	-328 to 1652	± 1.05	± 1.89
DIN Type U	DIN 43710	-200 to 600	-328 to 1112	± 1.05	± 1.89
Type W5Re/W26Re	ASTM E 988-96	0 to 2000	32 to 3632	± 2.1	± 3.78
Millivolt Input		-10 to 100 mV		± 0.045 mV	
2-, 3-, 4-wire Ohm Input		0 to 2000 ohms		± 1.35 ohm	

(1) The published digital accuracy applies over the entire sensor input range. Digital output can be accessed by HART Communications or wireless protocol.

(2) Total digital accuracy for thermocouple measurement: sum of digital accuracy +0.8 °C. (cold junction accuracy)

(3) Digital accuracy for NIST Type B T/C is ± 9.0 °C (± 16.2 °F) from 100 to 300 °C (212 to 572 °F).

(4) Digital accuracy for NIST Type K T/C is ± 2.1 °C (± 3.79 °F) from -180 to -90 °C (-292 to -130 °F).

Ambient Temperature Effect

TABLE 2. Ambient Temperature Effect

Sensor Options	Temperature Effects per 1.0 °C (1.8 °F) Change in Ambient Temperature ⁽¹⁾	Range
2-, 3-, 4-wire RTDs		
Pt 50 ($\alpha = 0.003910$)	0.018 °C (0.0324 °F)	Entire Sensor Input Range
Pt 100 ($\alpha = 0.00385$)	0.009 °C (0.0162 °F)	Entire Sensor Input Range
Pt 100 ($\alpha = 0.003910$)	0.009 °C (0.0162 °F)	Entire Sensor Input Range
Pt 100 ($\alpha = 0.003916$)	0.009 °C (0.0162 °F)	Entire Sensor Input Range
Pt 200 ($\alpha = 0.00385$)	0.012 °C (0.0216 °F)	Entire Sensor Input Range
Pt 200 ($\alpha = 0.003916$)	0.012 °C (0.0216 °F)	Entire Sensor Input Range
Pt 500	0.009 °C (0.0162 °F)	Entire Sensor Input Range
Pt 1000	0.009 °C (0.0162 °F)	Entire Sensor Input Range
Ni 120	0.009 °C (0.0162 °F)	Entire Sensor Input Range
Cu 10	0.06 °C (0.162 °F)	Entire Sensor Input Range
Cu 50 ($\alpha = 426$)	0.012 °C (0.0216 °F)	Entire Sensor Input Range
Cu 50 ($\alpha = 428$)	0.012 °C (0.0216 °F)	Entire Sensor Input Range
Cu 100 ($\alpha = 426$)	0.009 °C (0.0162 °F)	Entire Sensor Input Range
Cu 100 ($\alpha = 428$)	0.009 °C (0.0162 °F)	Entire Sensor Input Range
Thermocouples		
Type B	0.0435 °C	$R \geq 1000^{\circ}\text{C}$
	0.096 °C – (0.0075% of (R – 300))	$300^{\circ}\text{C} \leq R < 1000^{\circ}\text{C}$
	0.162 °C – (0.033% of (R – 100))	$100^{\circ}\text{C} \leq R < 300^{\circ}\text{C}$
Type E	0.015 °C + (0.00129% of R)	All
Type J	0.0162 °C + (0.00087% of R)	$R \geq 0^{\circ}\text{C}$
	0.0162 °C + (0.0075% of absolute value R)	$R < 0^{\circ}\text{C}$
Type K	0.0183 °C + (0.0027% of R)	$R \geq 0^{\circ}\text{C}$
	0.0183 °C + (0.0075% of absolute value R)	$R < 0^{\circ}\text{C}$
Type N	0.0204 °C + (0.00108% of R)	All
Type R, S, W5Re/W26Re	0.048 °C	$R \geq 200^{\circ}\text{C}$
	0.069 °C – (0.0108% of R)	$R < 200^{\circ}\text{C}$
Type T	0.0192 °C	$R \geq 0^{\circ}\text{C}$
	0.0192 °C + (0.0129% of absolute value R)	$R < 0^{\circ}\text{C}$
GOST L	0.021 °C	$R \geq 0^{\circ}\text{C}$
	0.0105 °C + (0.0045% of absolute value R)	$R < 0^{\circ}\text{C}$
DIN Type L	0.0162 °C + (0.00087% of R)	$R \geq 0^{\circ}\text{C}$
	0.0162 °C + (0.0075% of absolute value R)	$R < 0^{\circ}\text{C}$
DIN Type U	0.0192 °C	$R \geq 0^{\circ}\text{C}$
	0.0192 °C + (0.0129% of absolute value R)	$R < 0^{\circ}\text{C}$
Millivolt Input	0.0015 mV	Entire Sensor Input Range
2-, 3-, 4-wire Ohm	0.0252 Ω	Entire Sensor Input Range

(1) Change in ambient is with reference to the calibration temperature of the transmitter 68 °F (20 °C) from factory.

Transmitters can be installed in locations where the ambient temperature is between –40 and 85 °C (–40 and 185 °F). In order to maintain excellent accuracy performance, each transmitter is individually characterized over this ambient temperature range at the factory.

Temperature Effects Example

When using a Pt 100 ($\alpha = 0.00385$) sensor input at 30 °C ambient temperature:

- Digital Temperature Effects: $0.009^{\circ}\text{C} \times (30 - 20) = 0.09^{\circ}\text{C}$
- Worst Case Error: Digital + Digital Temperature Effects = $0.45^{\circ}\text{C} + 0.09^{\circ}\text{C} = 0.54^{\circ}\text{C}$
- Total Probable Error: $\sqrt{0.45^2 + 0.09^2} = 0.46$

DIMENSIONAL DRAWINGS

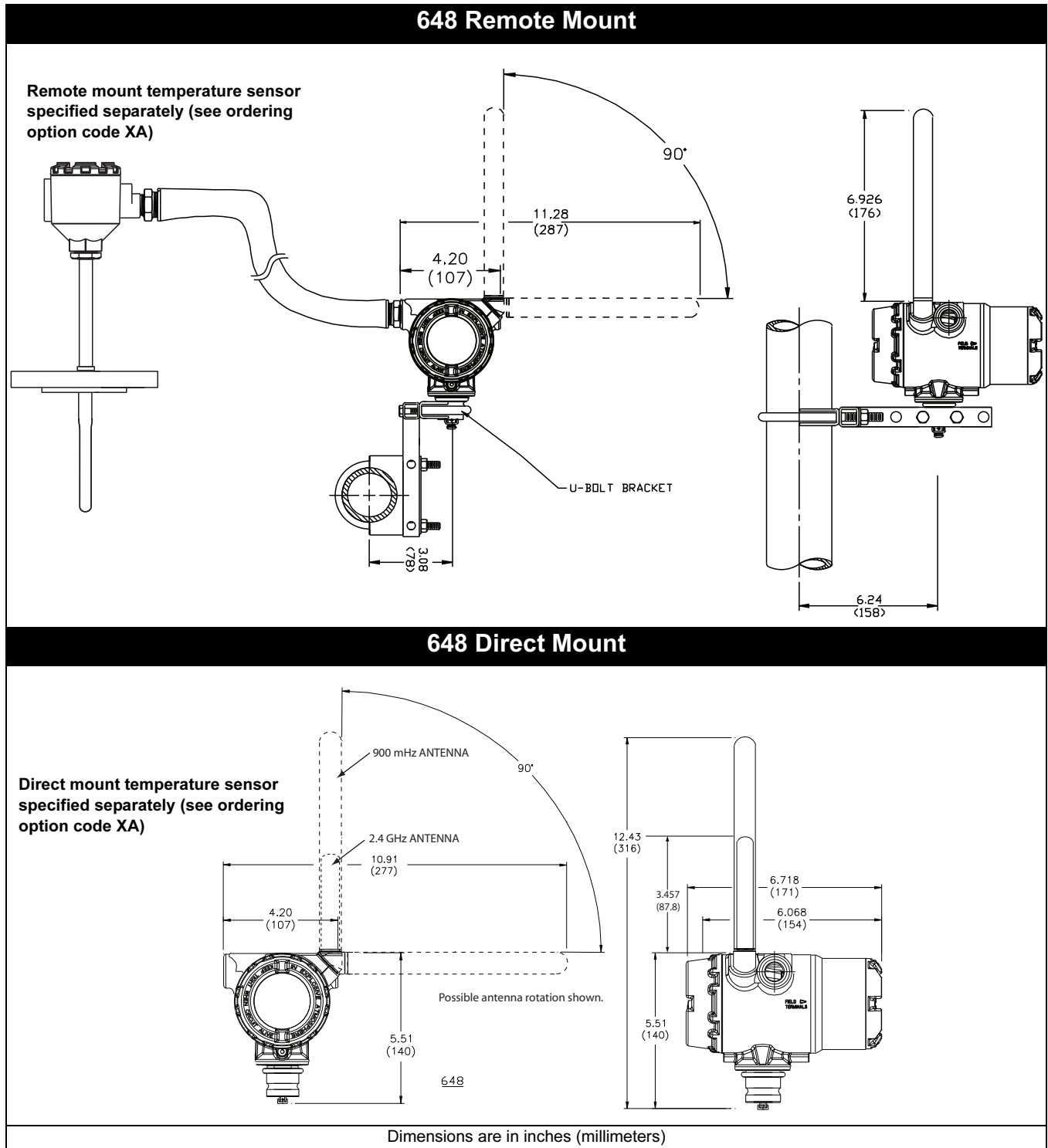

Rosemount 648

ORDERING INFORMATION

Model	Product Description	
648	Temperature Transmitter	
Code	Transmitter Type	
D	Wireless Field Mount	
Code	Output	
X	Wireless	
Code	Measurement	
1	Single Sensor	
Code	Housing	Metal
D	Dual Compartment Housing - Aluminum	AL
Code	Conduit Threads	
1	1/2-14 NPT	
Code	Certifications	
I5	FM Intrinsically Safe, Non-incendive	
I6	CSA Intrinsically Safe	
I1	ATEX Intrinsically Safe	
I7	IECEX Intrinsically Safe	
NA	No Approval	
Code	Wireless Options	
Wireless Transmit Rate		
WA	User Configurable Transmit Rate	
Operating Frequency and Protocol		
1	2.4 GHz DSSS, HART	
2	900 MHz FHSS, HART	
Antenna		
WK	Omnidirectional, Integral Antenna	
SmartPower™		
1	Long-life Intrinsically Safe Battery Pack	
Meter		
M5	LCD Meter	
Configuration		
C1	Factory Configure Date, Descriptor, & Message Fields	
Filter		
F6	60 Hz Line Voltage Filter	
F5	50 Hz Line Voltage Filter	
Trim		
C2	Transmitter-Sensor Matching - Trim to specific Rosemount RTD Calibration Schedule (CVD Constants)	
5-Point Calibration		
C4	5-Point Calibration (requires Q4 option code to generate a calibration certificate)	
Calibration Certificate		
Q4	Calibration Certificate (3-Point Calibration with Certificate)	
Cable Gland		
G2	Cable Gland (7.5 mm - 11.9 mm)	
G4	Thin Wire Cable Gland (3 mm - 8 mm)	
Sensor Options		
XA	Assemble to Transmitter, Sensor Specified Separately	
Typical Model Number: 648 D X 1 D 1 NA WA 2 WK 1 M5 C1 F6		

Appendix B Product Certifications

Approved Manufacturing Locations	page B-1
Telecommunication Compliance	page B-1
European Union Directive Information	page B-1
Ordinary Location Certification for FM	page B-2
Hazardous Locations Certificates	page B-2

Approved Manufacturing Locations

Rosemount Inc. - Chanhassen, Minnesota, USA
Emerson Process Management GmbH & Co. - Karlstein, Germany
Emerson Process Management Asia Pacific Private Limited - Singapore

Telecommunication Compliance

All wireless devices require certification to ensure that they adhere to regulations regarding the use of the RF spectrum. Nearly every country requires this type of product certification. Emerson is working with governmental agencies around the world to supply fully compliant products and remove the risk of violating country directives or laws governing wireless device usage. To see which countries our devices have received certification for use in, see www.rosemount.com/smartwireless.

FCC and IC

This device complies with Part 15 of the FCC Rules. Operation is subject to the following conditions: This device may not cause harmful interference, this device must accept any interference received, including interference that may cause undesired operation.

This device must be installed to ensure a minimum antenna separation distance of 20 cm from all persons.

European Union Directive Information

The EC declaration of conformity for all applicable European directives for this product can be found on the Rosemount website at www.rosemount.com. A hard copy may be obtained by contacting your local sales representative.

ATEX Directive (94/9/EC)

Emerson Process Management complies with the ATEX Directive.

Electro Magnetic Compatibility (EMC) (89/336/EEC)

EN 50081-1: 1992; EN 50082-2: 1995;
EN 61326-1: 1997 — Industrial

Radio and Telecommunications Terminal Equipment Directive (R&TTE) (1999/5/EC)

Emerson Process Management complies with the R&TTE Directive.

Rosemount 648

Ordinary Location Certification for FM

As standard, the transmitter has been examined and tested to determine that the design meets basic electrical, mechanical, and fire protection requirements by FM, a nationally recognized testing laboratory (NRTL) as accredited by the Federal Occupational Safety and Health Administration (OSHA).

Hazardous Locations Certificates

North American Certifications

Factory Mutual (FM) Approvals

- I5 FM Intrinsic Safety and Non-incendive
Intrinsically Safe for Class I/II/III, Division 1, Groups A, B, C, D, E, F, and G.
Zone Marking: Class I, Zone 0, AEx ia IIC
Temperature Codes T4 ($T_{amb} = -50$ to $70^{\circ}C$)
T5 ($T_{amb} = -50$ to $40^{\circ}C$)
Non-incendive for Class I, Division 2, Groups A, B, C, and D.
Dust Ignitionproof for Class II/III, Division 1, Groups E, F, and G.
Ambient temperature limits: -50 to $85^{\circ}C$
Intrinsically Safe and non-incendive when installed in accordance with Rosemount drawing 00648-1000.
For use with Rosemount battery pack P/N 753-9220-XXXX only.
Enclosure Type 4X / IP66

CSA - Canadian Standards Association

- I6 CSA Intrinsic Safety
Intrinsically Safe for Class I, Division 1, Groups A, B, C, and D.
Temp Code T3C
Enclosure Type 4X / IP66
For use with Rosemount battery pack P/N 753-9220-XXXX only
Intrinsically Safe when installed per Rosemount drawing 00648-1020

European Certifications

- I1 ATEX Intrinsic Safety
Certificate No.: Baseefa07ATEX0011  II 1G
Ex ia IIC T5 ($T_a = -60^{\circ}C$ to $40^{\circ}C$)
Ex ia IIC T4 ($T_a = -60^{\circ}C$ to $70^{\circ}C$)
IP66
For use with Rosemount battery pack P/N 753-9220-XXXX only

 1180

Table B-1. Sensor Parameters

Sensor
$U_o = 6.6 V$
$I_o = 3.6 mA$
$P_o = 23.3 mW$
$C_o = 11 \mu F$
$L_o = 500 mH$

IECEX Certifications

- 17 IECEX Intrinsic Safety
 Certificate No.: IECEX BAS 07.0007
 Ex ia IIC T6 ($T_{amb} = -60\text{ }^{\circ}\text{C}$ to $50\text{ }^{\circ}\text{C}$)
 Ex ia IIC T5 ($T_{amb} = -60\text{ }^{\circ}\text{C}$ to $75\text{ }^{\circ}\text{C}$)
 IP66
 For use with Rosemount battery pack P/N 753-9220-XXXX only

Table B-2. Sensor Parameters

Sensor
$U_o = 6.6\text{ V}$
$I_o = 3.6\text{ mA}$
$P_o = 23.3\text{ mW}$
$C_o = 11\text{ }\mu\text{F}$
$L_o = 500\text{ mH}$



Table 1.

Country	Restriction
Bulgaria	General authorization required for outdoor use and public service
France	Outdoor use limited to 10mW e.i.r.p.
Italy	If used outside of own premises, general authorization is required.
Norway	May be restricted in the geographical area within a radius of 20 km from the center of Ny-Alesund.
Romania	Use on a secondary basis. Individual license required.

Radio Power Label - see Figure B1- indicates output power configuration of the radio. Devices with this label are configured for output power less than 10 mW e.i.r.p. At time of purchase the customer must specify ultimate country of installation and operation.

Figure B-1.

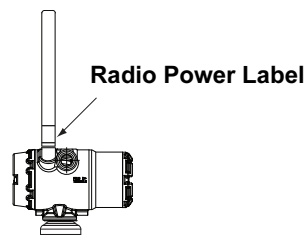

Figure B-2. Rosemount 648 Intrinsically Safe Installation Drawing

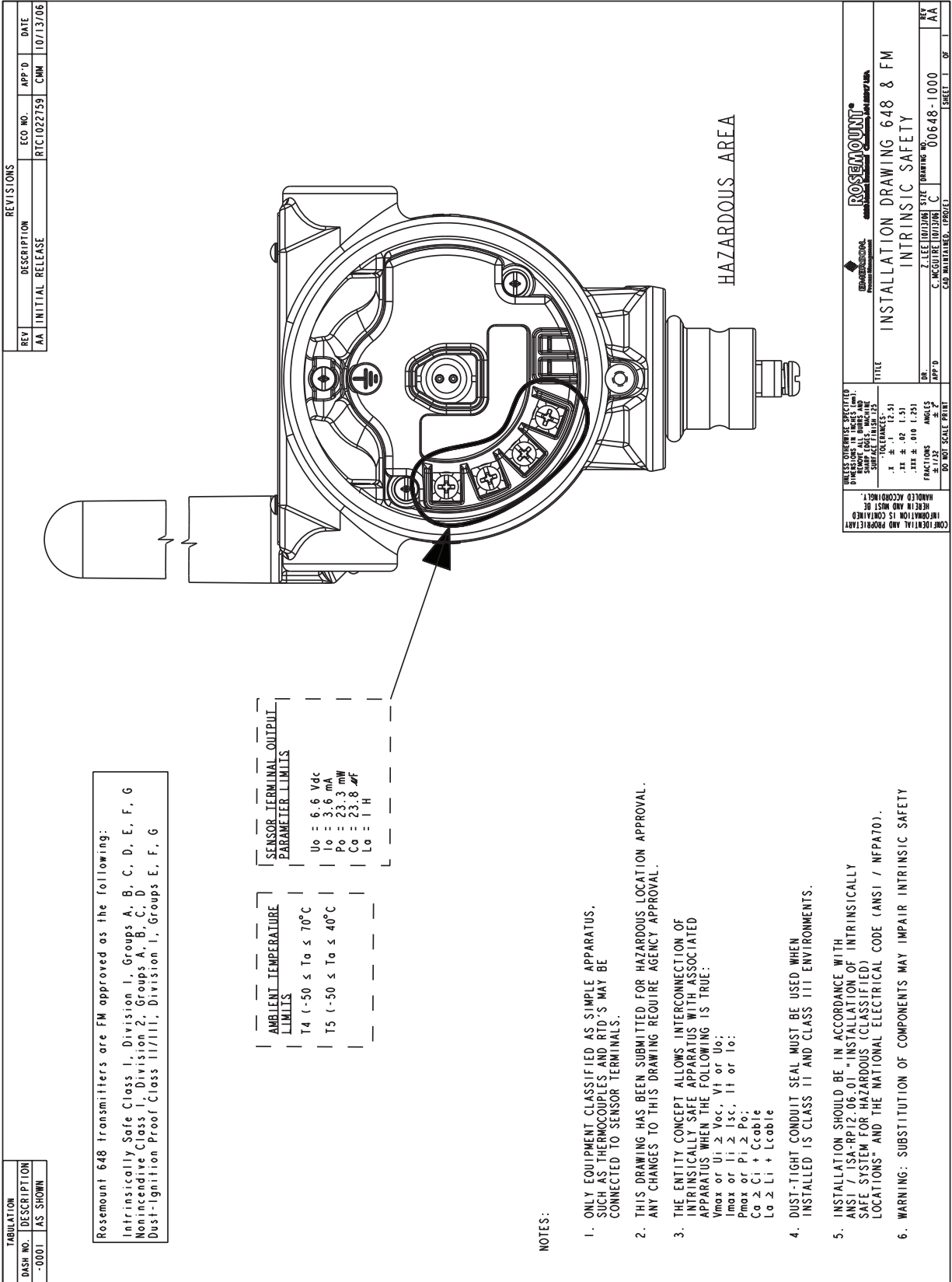
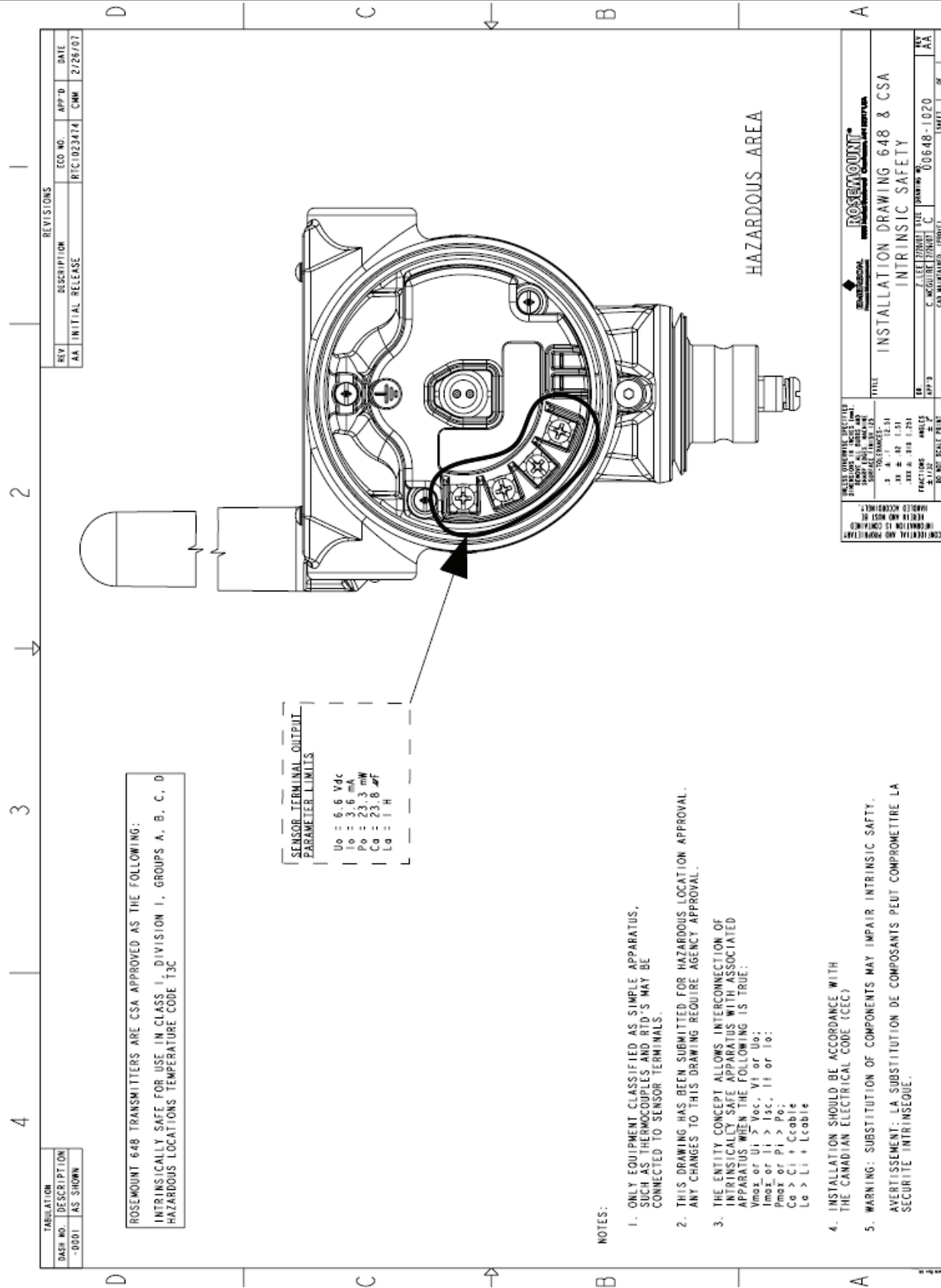

Figure B-3. CSA Installation Drawing



*The Emerson logo is a trade mark and service mark of Emerson Electric Co.
Rosemount and the Rosemount logotype are registered trademarks of Rosemount Inc.
PlantWeb is a registered trademark of one of the Emerson Process Management group of companies.
HART is a registered trademark of the HART Communication Foundation.
Lexan and Noryl are registered trademark of General Electric.
All other marks are the property of their respective owners.*

Emerson Process Management

Rosemount Inc.

8200 Market Boulevard
Chanhassen, MN 55317 USA
T (U.S.) 1-800-999-9307
T (International) (952) 906-8888
F (952) 949-7001

www.rosemount.com



Emerson Process Management

Heath Place
Bognor Regis
West Sussex PO22 9SH
England
T 44 (1243) 863 121
F 44 (1243) 867 554

**Emerson Process Management Asia
Pacific Private Limited**

1 Pandan Crescent
Singapore 128461
T (65) 6777 8211
F (65) 6777 0947
AP.RMT-Specialist@emersonprocess.com



EMERSON™
Process Management