

Smart Wireless THUM™ Adapter



WirelessHART

ROSEMOUNT®

www.rosemount.com



EMERSON™
Process Management

Smart Wireless THUM™ Adapter

| | |
|--|----------------|
| Smart Wireless THUM™ Adapter Hardware Revision | 1 |
| HART® Device Revision | 1 |
| Field Communicator Field Device Revision | Dev v2.5 DD v4 |

NOTICE

Read this manual before working with the product. For personal and system safety, and for optimum product performance, make sure to thoroughly understand the contents before installing, using, or maintaining this product.

The United States has two toll-free assistance numbers and one international number.

Customer Central

1 800 999 9307 (7:00 a.m. to 7:00 p.m. CST)

National Response Center

1 800 654 7768 (24 hours a day)

Equipment service needs

International

1 952 906 8888

⚠ CAUTION

The products described in this document are NOT designed for nuclear-qualified applications.

Using non-nuclear qualified products in applications that require nuclear-qualified hardware or products may cause inaccurate readings.

For information on Rosemount nuclear-qualified products, contact an Emerson Process Management Sales Representative.

⚠ WARNING

Explosions could result in death or serious injury:

Installation of this transmitter in an explosive environment must be in accordance with the appropriate local, national, and international standards, codes, and practices. Please review the Product Certifications section for any restrictions associated with a safe installation.

- Before connecting a Field Communicator in an explosive atmosphere, ensure the instruments are installed in accordance with intrinsically safe or non-incendive field wiring practices.

Electrical shock can result in death or serious injury:

- Avoid contact with the leads and terminals. High voltage that may be present on leads can cause electrical shock.

This device complies with Part 15 of the FCC Rules. Operation is subject to the following conditions. This device may not cause harmful interference. This device must accept any interference received, including interference that may cause undesired operation.

This device must be installed to ensure a minimum antenna separation distance of 20 cm from all persons.

NOTICE

The THUM and all other wireless devices should be installed only after the Smart Wireless Gateway has been installed and is functioning properly. Wireless devices should also be powered up in order of proximity from the Smart Wireless Gateway, beginning with the closest. This will result in a simpler and faster network installation.

NOTICE

During normal operation, or in fault condition, the THUM will cause a 2.5 V drop in the connected loop. It is important to ensure that the power supply can provide at least 2.5 V more than the lift off voltage of the wired device to make sure it works properly with the THUM installed. To determine the lift off voltage for the wired device, review the wired device operation and installation manual.

Table of Contents

| | |
|--------------------------------------|--|
| SECTION 1 | |
| Introduction | |
| | Safety Messages 1-1 |
| | Overview 1-2 |
| | Considerations 1-3 |
| | Temperature Limits 1-3 |
| | Power Up Sequence 1-3 |
| | THUM Adapter Position 1-3 |
| | Conduit Entry 1-4 |
| | M20 Conduit Adapter 1-4 |
| | Field Communicator Connections 1-4 |
| | Power Supply 1-4 |
| | Load Resistor 1-4 |
| | Service Support 1-5 |
| | Product Recycling/Disposal 1-5 |
| | |
| SECTION 2 | |
| Configuration | |
| | Safety Messages 2-1 |
| | Connections 2-2 |
| | Device Sensor Configuration 2-2 |
| | Field Communicator 2-2 |
| | AMS Wireless Configurator 2-2 |
| | Connection Diagrams 2-2 |
| | Bench Hook-up 2-2 |
| | Field Hook-Up 2-2 |
| | Device Network Configuration 2-3 |
| | HART Tree 2-5 |
| | |
| SECTION 3 | |
| Mounting | |
| | Safety Messages 3-1 |
| | Mounting 3-2 |
| | Loop Current Test 3-14 |
| | AMS 3-14 |
| | Field Communicator 3-14 |
| | AMS 3-15 |
| | Field Communicator 3-15 |
| | |
| SECTION 4 | |
| Commissioning | |
| | Safety Messages 4-1 |
| | Device Network Configuration 4-2 |
| | AMS 4-2 |
| | Field Communicator 4-2 |
| | Field Communicator 4-3 |
| | Smart Wireless Gateway 4-3 |
| | AMS Wireless Configurator 4-4 |
| | Troubleshooting 4-4 |
| | Reference Information 4-4 |
| | |
| SECTION 5 | |
| Operation and Maintenance | |
| | Safety Messages 5-1 |
| | Startup Sequence 5-2 |
| | Advanced Setup 5-2 |

Smart Wireless THUM Adapter

| | | |
|-------------------------------|--|-----|
| SECTION 6 | Overview | 6-1 |
| Troubleshooting | | |
| APPENDIX A | Functional Specifications | A-1 |
| Reference Data | Physical Specifications | A-1 |
| | Performance Specifications | A-2 |
| | Dimensional Drawings | A-3 |
| | Ordering Information | A-5 |
| | Accessories and Spare Parts | A-5 |
| APPENDIX B | North American Certifications | B-1 |
| Product Certifications | CSA - Canadian Standards Association | B-2 |
| | European Certifications | B-2 |
| | IECEX Certifications | B-3 |
| | INMETRO Certifications | B-3 |
| | China (NEPSI) Certifications | B-3 |
| | CCoE Certifications | B-3 |
| | KOSHA Certifications | B-3 |
| | GOST Certifications | B-3 |

Section 1 Introduction

| | |
|---|-----------------|
| Safety Messages | page 1-1 |
| Overview | page 1-2 |
| Considerations | page 1-3 |
| Service Support | page 1-5 |
| Product Recycling/Disposal | page 1-5 |

SAFETY MESSAGES

Instructions and procedures in this section may require special precautions to ensure the safety of the personnel performing the operations. Information that potentially raises safety issues is indicated by a warning symbol (⚠). Please refer to the following safety messages before performing an operation preceded by this symbol.

Warnings

⚠ WARNING

Failure to follow these installation guidelines could result in death or serious injury.

- Make sure only qualified personnel perform the installation.

Explosions could result in death or serious injury.

- Before connecting a Field Communicator in an explosive atmosphere, make sure the instruments are installed in accordance with intrinsically safe or non-incendive field wiring practices.
- Verify that the operating atmosphere of the transmitter is consistent with the appropriate hazardous locations certifications.

Electrical shock could cause death or serious injury.

- Use extreme caution when making contact with the leads and terminals.

Smart Wireless THUM Adapter

OVERVIEW

Manual

This manual is designed to assist in the installation, operation, and maintenance of the Smart Wireless THUM™ Adapter.

Section 1: Introduction

- Manual and Transmitter Overview
- Considerations
- Return of Materials

Section 2: Configuration

- Device Sensor Configuration
- Device Network Configuration

Section 3: Mounting

- Mount the Sensor
- Sensor Assembly/Leads
- Grounding

Section 4: Commissioning

- Network Status
- Verify Operation

Section 5: Operation and Maintenance

- Startup Sequence
- Advanced Setup

Appendix A: Reference Data

- Specifications
- Dimensional Drawings
- Ordering Information

Appendix B: Product Certifications

- Product Certifications
- Installation Drawings

Features

- An installation-ready solution that provides rich wireless HART® data
- Works with any 2- or 4-wire HART devices
- Flexibility to meet your most demanding applications
- Wireless output with >99% data reliability delivers rich HART data, protected by industry leading security
- Gain access to additional HART information, such as diagnostics or multi-variable data
- Add wireless to almost any measurement point without affecting the approval of the sub-device
- IEC 62591 (WirelessHART™) capabilities extend the full benefits of PlantWeb® to previously inaccessible locations

CONSIDERATIONS

General

The Smart Wireless THUM Adapter is connected to a HART sub-device. With simple HART configuration, the THUM transmits the HART information from the sub-device into the Wireless network.

Commissioning

The THUM can be commissioned before or after installation. It may be useful to bench commission the THUM before installation to ensure proper operation and to become familiar with the functionality. The instruments should be installed in accordance with intrinsically safe or non-incendive field wiring practices, when required. The THUM Adapter is powered when connected to a powered loop.

Mechanical

When choosing an installation location and position for the transmitter, take into account access to the device. For best performance, the antenna should be vertical and have some space between objects in a parallel metal plane such as a pipe or metal framework, as the pipes or framework may adversely affect the performance of the antenna.

Electrical

The THUM Adapter is connected into a powered 4–20 mA loop, powering itself by scavenging power. The THUM Adapter causes a voltage drop across the loop. The drop is linear from 2.25 volts at 3.5 mA to 1.2 volts at 25 mA, but does not effect the 4–20 mA signal on the loop. Under fault conditions, the maximum voltage drop is 2.5 volts.

Environmental

Verify that the operating environment of the transmitter is consistent with the appropriate hazardous locations certifications.

Temperature Limits

| Operating Limit | Storage Limit |
|-----------------|---------------|
| –40 to 185 °F | –40 to 185 °F |
| –40 to 85 °C | –40 to 85 °C |

Wireless Considerations

Power Up Sequence

Power should not be applied to any wireless device until the Smart Wireless Gateway (“Gateway”) is installed and functioning properly. Wireless devices should also be powered up in order of proximity from the Gateway, beginning with the closest. This will result in a simpler and faster network installation. Enable Active Advertising on the Gateway to ensure that new devices join the network faster. For more information see the Smart Wireless Gateway Manual (Doc. No. 00809-0200-4420).

THUM Adapter Position

If possible, the THUM Adapter should be positioned vertically, either straight up or straight down, and it should be approximately 3 ft. (1 m) from any large structure, building, or conductive surface to allow for clear communication to other devices. If the THUM Adapter is mounted horizontally, wireless communication range may be decreased.

Smart Wireless THUM Adapter

Figure 1-1. THUM Adapter Position

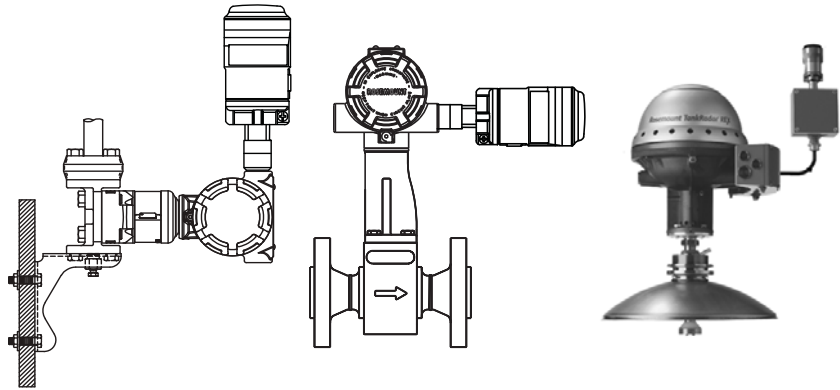

Conduit Entry

When installing the THUM Adapter into the conduit entry of a wired device, use an approved thread sealant. Thread sealant provides a water tight seal. The thread sealant also provides a lubrication to ensure easy removal of the THUM Adapter.

M20 Conduit Adapter

When using the M20 Conduit Adapter on the THUM Adapter, use an approved thread sealant and tighten wrench tight to the THUM Adapter. When installing the M20 conduit adapter into a conduit tighten to 32.5 Nm/25 ft-lb. to ensure water tight seal.

Field Communicator Connections

In order for the Field Communicator to interface with the THUM Adapter, the wired device must be powered. The Field Communicator must be put into poll mode and should use the THUM Adapter address of 63.

Power Supply

Minimum loop load of 250 Ohms.
The THUM Adapter communicates and derives power from a standard 4-20 mA/HART loop. The THUM Adapter causes a small voltage drop on the loop which is linear from 2.25 V at 3.5 mA to 1.2 V at 25 mA. Under fault conditions, the maximum voltage drop is 2.5 V. The THUM Adapter will not affect the 4-20 mA signal under normal or fault conditions as long as the loop has at least a 2.5 V margin at the maximum loop current (25 mA for a typical 4-20 mA/HART device).

Limit the power supply to 0.5 Amps maximum, and voltage to 55 Vdc.

| Loop Current | THUM Adapter voltage drop |
|--------------|---------------------------|
| 3.5 mA | 2.25 V |
| 25 mA | 1.2 V |

Load Resistor

If required, add a load resistor as shown in Figure 3-20, 3-22, and 3-24. The resistor should be adequately rated for the application (1W minimum) and be compatible with the supplied splice connector which accepts wire sizes from 14 to 22 AWG.

When adding a load resistor, ensure that uninsulated conductors do not contact the enclosure and/or other exposed metal parts.

SERVICE SUPPORT

To expedite the return process outside of North America, contact your Emerson Process Management representative.

Within the United States, call the Emerson Process Management Response Center toll-free number 1 800 654 7768. The center, which is available 24 hours a day, will assist you with any needed information or materials.

The center will ask for product model and serial numbers, and will provide a Return Material Authorization (RMA) number. The center will also ask for the process material to which the product was last exposed.

⚠ CAUTION

Individuals who handle products exposed to a hazardous substance can avoid injury if they are informed of, and understand, the hazard. If the product being returned was exposed to a hazardous substance as defined by OSHA, a copy of the required Material Safety Data Sheet (MSDS) for each hazardous substance identified must be included with the returned goods.

PRODUCT RECYCLING/DISPOSAL

Recycling of equipment and packaging should be taken into consideration and disposed of in accordance with local and national legislation/regulations.

Smart Wireless THUM Adapter

Section 2 Configuration

| | |
|------------------------------------|----------|
| Safety Messages | page 2-1 |
| Connections | page 2-2 |
| Device Sensor Configuration | page 2-2 |
| Connection Diagrams | page 2-2 |
| Device Network Configuration | page 2-3 |
| HART Tree | page 2-5 |

SAFETY MESSAGES

Instructions and procedures in this section may require special precautions to ensure the safety of the personnel performing the operations. Information that potentially raises safety issues is indicated by a warning symbol () . Please refer to the following safety messages before performing an operation preceded by this symbol.

Warnings

WARNING

Failure to follow these installation guidelines could result in death or serious injury:

- Only qualified personnel should perform the installation

Explosions could result in death or serious injury.

- Before connecting a Field Communicator in an explosive atmosphere, make sure that the instruments are installed in accordance with intrinsically safe or non-incendive field wiring practices
- Verify that the operating atmosphere of the transmitter is consistent with the appropriate hazardous locations certifications

Electrical shock could cause death or serious injury.

- Use extreme caution when making contact with the leads and terminals

This device complies with Part 15 of the FCC Rules. Operation is subject to the following conditions: This device may not cause harmful interference. This device must accept any interference received, including interference that may cause undesired operation.

This device must be installed to ensure a minimum antenna separation distance of 20 cm from all persons.

Smart Wireless THUM Adapter

CONNECTIONS

Section 2 details wiring the THUM Adapter to the different types of compatible sub-devices.

DEVICE SENSOR CONFIGURATION

The THUM Adapter, attached to a powered sub-device, receives HART[®] communication from a handheld Field Communicator or AMS[®].

Field Communicator

In order to communicate with the THUM Adapter, polling must be activated on the Field Communicator. The default address for the THUM Adapter is 63. Also, note that any configuration changes must be sent to the transmitter using the **Send** key (F2).

AMS Wireless Configurator

AMS is capable of connecting devices directly using a HART modem or the Gateway. For configuring through AMS Wireless Configurator, double click the device icon and choose the Configure/Setup tab. AMS configuration changes are implemented when the **Apply** button is selected.

CONNECTION DIAGRAMS

Bench Hook-up

Connect the bench equipment as shown in either Figure 2-1 or Figure 2-2, and turn on the Field Communicator by pressing the **ON/OFF** key or log into AMS. The Field Communicator or AMS will search for a HART-compatible device and indicate when the connection is made. If the Field Communicator or AMS fail to connect, it indicates that no device was found. If this occurs, refer to Section 4: Commissioning.

Field Hook-Up

Section 2: Configuration details the field hook-up requirements in Figure 2-1 and Figure 2-2.

Figure 2-1. THUM Adapter Only, Powered by a Current Source

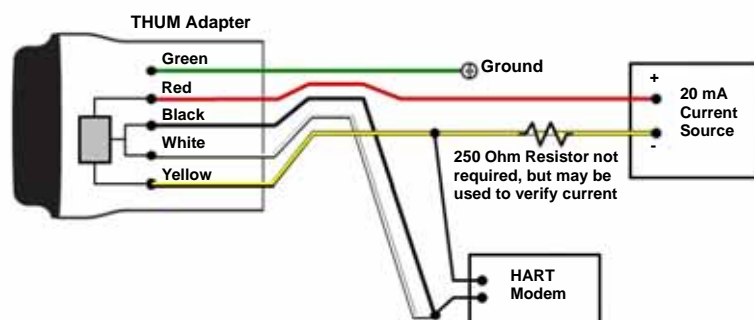
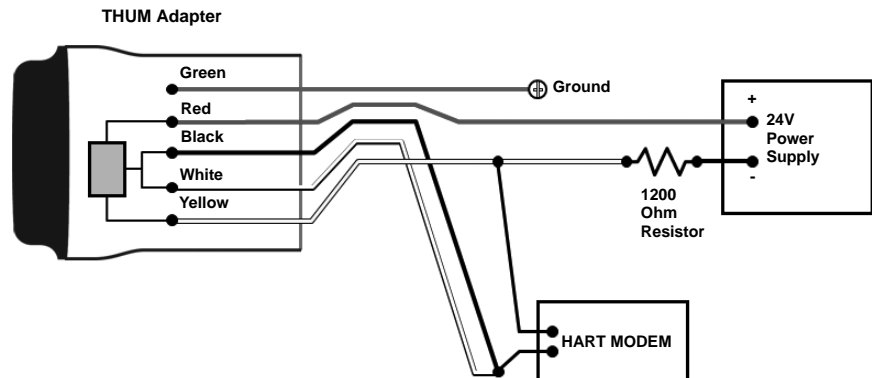

Figure 2-2. THUM Adapter Only, Powered by a 24 V Power Supply with 1200 Ohm resistor to limit current to 20 mA



The 1200 Ohm resistor should be adequately rated for the application (3W minimum).

DEVICE NETWORK CONFIGURATION

Join Device to Network

| | |
|-----------|---------|
| Fast Keys | 2, 1, 1 |
|-----------|---------|

In order to communicate with the Smart Wireless Gateway, and ultimately the Host System, the THUM must be configured to communicate over the wireless network. This step is the wireless equivalent of connecting wires from a transmitter to the host system.

1. From the *Home* screen, select **2: Configure**.
2. Select **1: Guided Setup**.
3. Select **1: Join Device to Network**.

Using a Field Communicator or AMS, enter the Network ID and Join Key so that they match the Network ID and Join Key of the Smart Wireless Gateway and other devices in the network. If the Network ID and Join Key are not identical to those set in the Gateway, the THUM will not communicate with the network. The Network ID and Join Key may be obtained from the Smart Wireless Gateway on the **Setup>Network>Settings** page on the web server.

Configure Update Rate

| | |
|-----------|---------|
| Fast Keys | 2, 1, 2 |
|-----------|---------|

The Update Rate is the frequency at which a new measurement is taken and transmitted over the wireless network. This by default is 1 minute. This may be changed at commissioning, or at any time via AMS Wireless Configurator. The Update Rate is user selectable from 8 seconds to 60 minutes.

1. From the Home screen, select **2: Configure**.
2. Select **1: Guided Setup**.
3. Select **2: Configure Update Rate**.

Smart Wireless THUM Adapter

Configure THUM Long Tag

| | |
|-----------|------------|
| Fast Keys | 2, 2, 4, 2 |
|-----------|------------|

The Long Tag is how the THUM Adapter will show up in the Smart Wireless Gateway web interface. By setting this parameter to a unique value it will be easier to determine which THUM Adapter you are communicating with. One way to do this is to use the tag number of the wired device that the THUM adapter is connected to followed by THUM (HARTTAG-THUM).

1. From the Home screen, select **2: Configure**.
2. Select **1: Manual Setup**.
3. Select **2: Device Information tab**.
4. Enter the Long Tag.

Wired Device Tag

For HART 5 devices the THUM Adapter uses the message field when reporting the HART tag to the Smart Wireless Gateway. To ensure that you can identify the wired device in the Gateway make sure to write the tag information into the message field for all HART 5 devices. For HART 6 or newer devices the THUM reports the long tag as the HART tag to the Gateway.

HART TREE

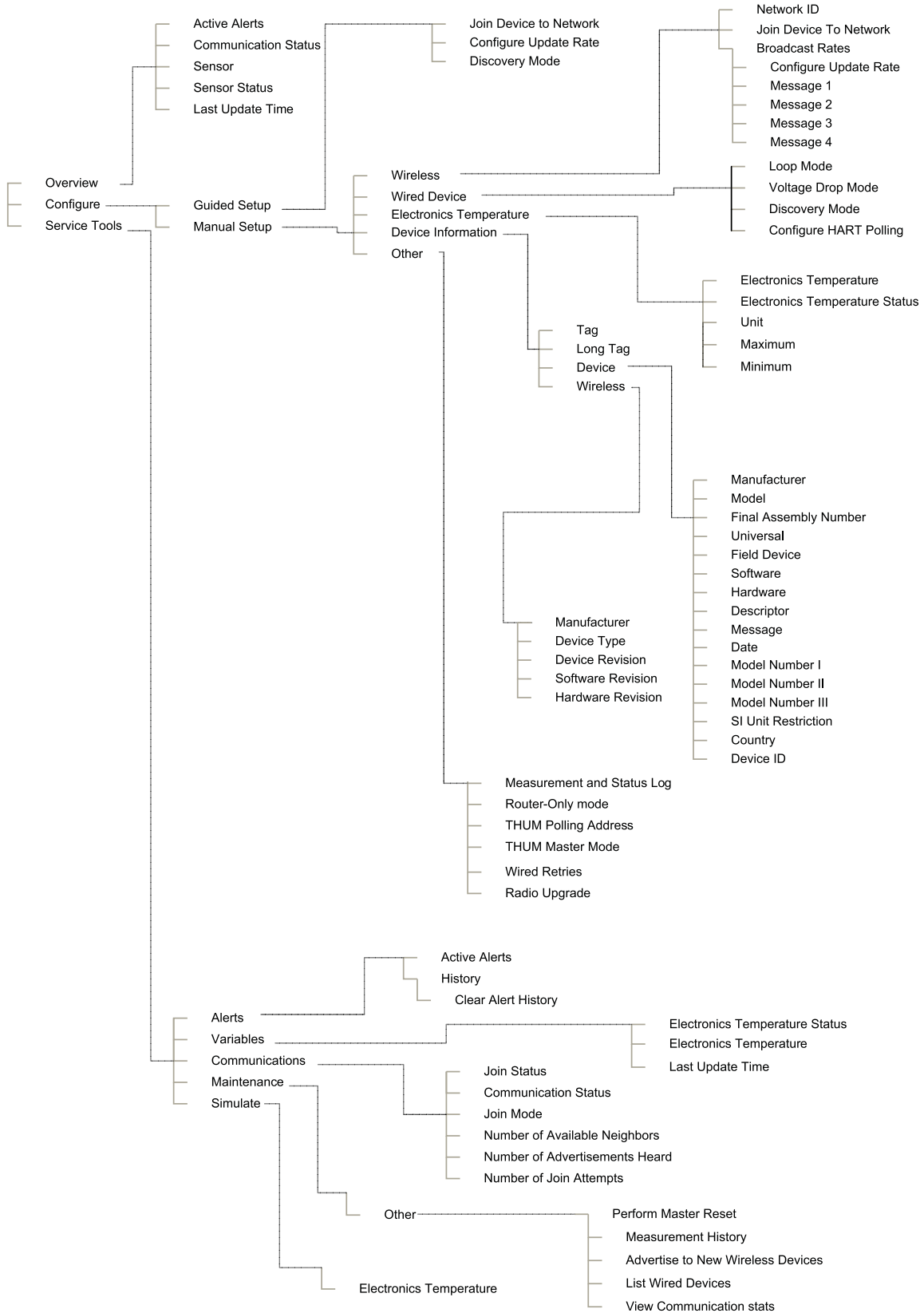

Smart Wireless THUM Adapter

Reference Manual
00809-0100-4075, Rev BA
October 2010

Section 3 Mounting

| | |
|--------------------------------|------------------|
| Safety Messages | page 3-1 |
| Mounting | page 3-2 |
| Loop Current Test | page 3-14 |

SAFETY MESSAGES

Instructions and procedures in this section may require special precautions to ensure the safety of the personnel performing the operations. Information that potentially raises safety issues is indicated by a warning symbol (⚠). Please refer to the following safety messages before performing an operation preceded by this symbol.

Warnings

⚠ WARNING

Failure to follow these installation guidelines could result in death or serious injury:

- Only qualified personnel should perform the installation

Explosions could result in death or serious injury.

- Before connecting a Field Communicator in an explosive atmosphere, make sure that the instruments are installed in accordance with intrinsically safe or non-incendive field wiring practices
- Verify that the operating atmosphere of the transmitter is consistent with the appropriate hazardous locations certifications

Electrical shock could cause death or serious injury.

- Use extreme caution when making contact with the leads and terminals

This device complies with Part 15 of the FCC Rules. Operation is subject to the following conditions: This device may not cause harmful interference. This device must accept any interference received, including interference that may cause undesired operation.

This device must be installed to ensure a minimum antenna separation distance of 20 cm from all persons.

Smart Wireless THUM Adapter

MOUNTING

The THUM can be installed in one of two configurations:

Direct Mount: The THUM Adapter is connected directly to the conduit entry of the wired device.

Figure 3-1. Direct Mount

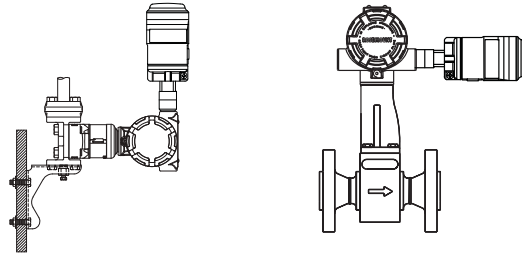

Direct Mount

1. Install the HART® device according to standard installation practices, being sure to use an approved thread sealant on all connections.
2. Attach the THUM Adapter to the wired device as shown in Figure 3-1. When installing the THUM Adapter into the conduit entry of a wired device, use an approved thread sealant.
3. Connect the THUM Adapter to the HART wired device using the wiring diagrams below. See Figure 3-19 through 3-26 on the following pages.
4. Close the housing cover on the HART wired device, so that metal touches metal, but do not over tighten to prevent damaging the unit.

NOTE

Two splice connectors are included with the THUM Adapter. The first is a two connection splice. The second is a three connection splice for use with a resistor, if there is not enough resistance in the loop. Both of these splice connectors can accept 14 to 22 gauge wire. See wired device reference manual for information on the required loop resistance.

Remote Mount: The THUM Adapter is mounted separate from the wired device housing and then connected to the wired device using conduit.

Figure 3-2. Remote Mount

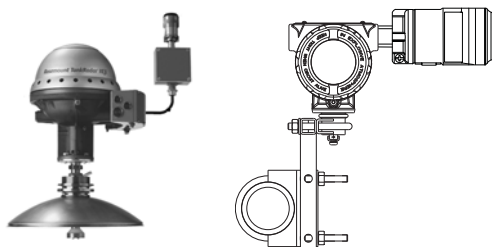

Remote Mount

1. Install the HART device according to standard installation practices, being sure to use an approved thread sealant on all connections.
2. The THUM Adapter should be mounted as shown in Figure 3-2 on page 3-2.
3. Connect the THUM Adapter to the wired device using standard practices. Wire running from the THUM Adapter to the wired device must be shielded or in conduit.
4. Ground the Remote Mount Kit per local practices.
5. Connect the THUM Adapter to the HART wired device using the wiring diagrams below. See Figure 3-19 through 3-26 on the following pages.
6. Close the housing cover on the HART wired device, so that metal touches metal, but do not over tighten to prevent damaging the unit.

NOTE

Two splice connectors are included with the THUM Adapter. The first is a two connection splice. The second is a three connection splice for use with a resistor, if there is not enough resistance in the loop. Both of these splice connectors can accept 14 to 22 gauge wire. See wired device reference manual for information on the required loop resistance.

Power Supply

Minimum loop load of 250 Ohms.

The THUM Adapter communicates and derives power from a standard 4-20 mA/HART loop. The THUM Adapter causes a small voltage drop on the loop which is linear from 2.25 V at 3.5 mA to 1.2 V at 25 mA. Under fault conditions, the maximum voltage drop is 2.5 V. The THUM Adapter will not affect the 4-20 mA signal under normal or fault conditions as long as the loop has at least a 2.5 V margin at the maximum loop current (25 mA for a typical 4-20 mA/HART device).

Limit the power supply to 0.5 Amps maximum, and voltage to 55 Vdc.

| Loop Current | THUM Adapter voltage drop |
|--------------|---------------------------|
| 3.5 mA | 2.25 V |
| 25 mA | 1.2 V |

Load Resistor

If required, add a load resistor as shown in Figure 3-20, Figure 3-22, and Figure 3-24. The resistor should be adequately rated for the application (1W minimum) and be compatible with the supplied splice connector which accepts wire sizes from 14 to 22 AWG.

Smart Wireless THUM Adapter

Wiring

NOTE:

In order for the THUM Adapter to function properly there must be at least 250 Ohms resistance in the loop. If the 4–20 mA loop does not have the required resistance, wire a resistor as shown in Figure 3-20, Figure 3-22, or Figure 3-24 as applicable.

When adding a load resistor ensure that uninsulated conductors do not contact the enclosure and/or other exposed metal parts.

Figure 3-3. Direct Mount Wiring Diagram for 2-Wire Device

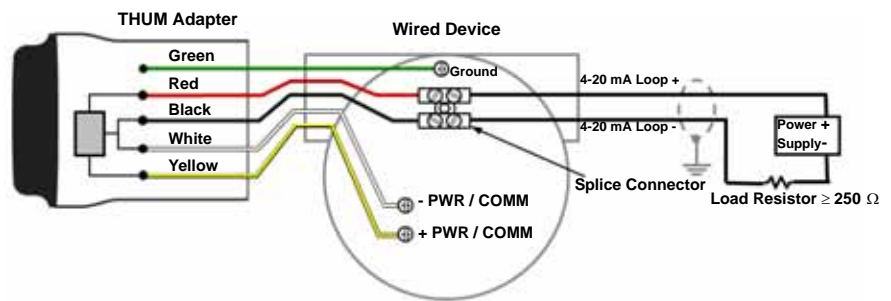

NOTE:

In order for the THUM Adapter to function properly there must be at least 250 Ohms resistance in the loop. If the 4–20 mA loop does not have the required resistance, wire a resistor as shown in Figure 3-6, 3-10, or 3-13 as applicable.

Figure 3-4. Remote Mount Wiring Diagram for 2-Wire Device

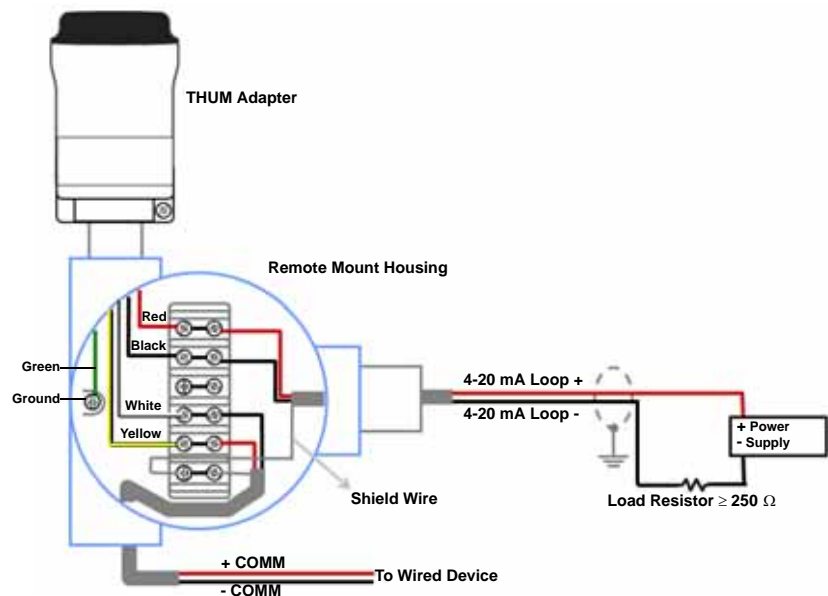

Figure 3-5. Direct Mount Wiring Diagram for 2-Wire Device with Resistor

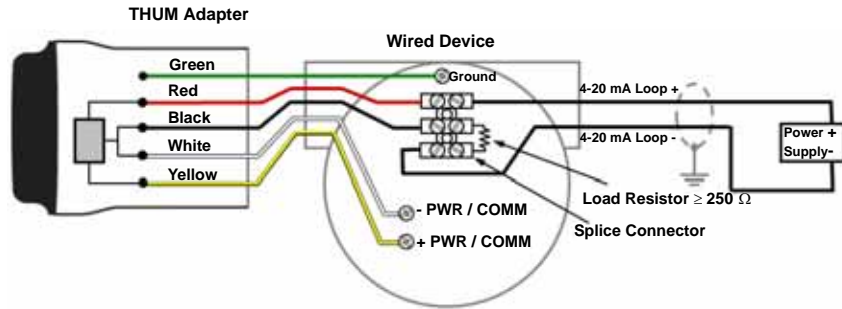
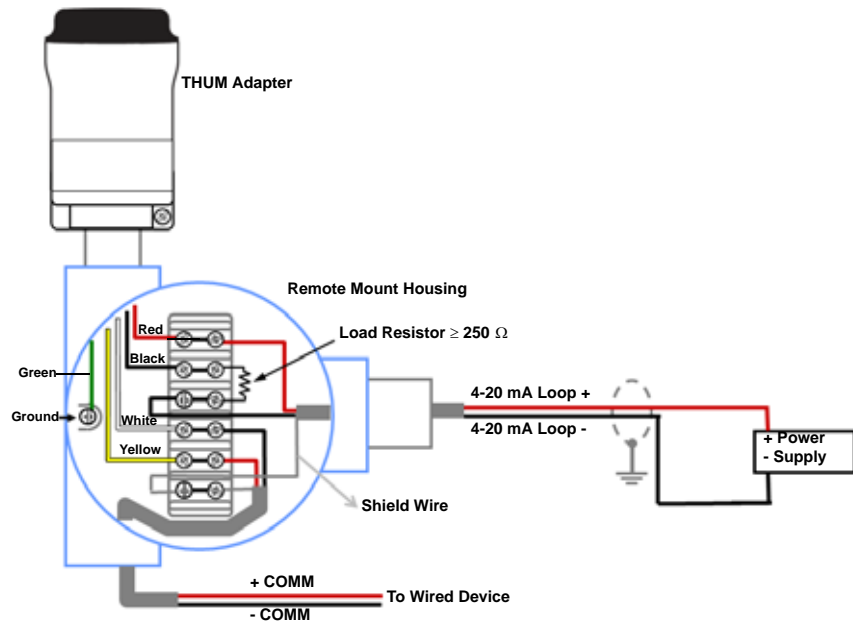
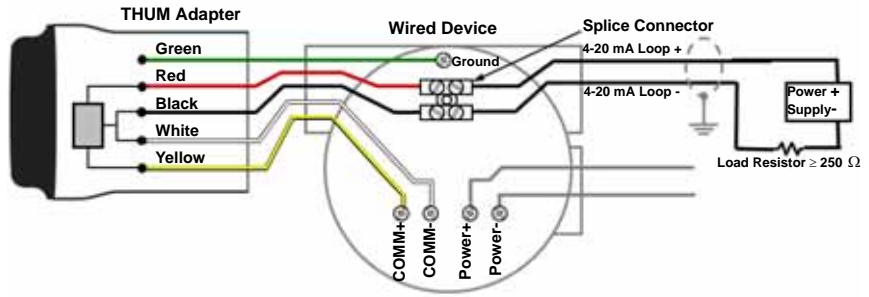

Figure 3-6. Remote Mount Wiring Diagram for 2-Wire Device with Resistor



Smart Wireless THUM Adapter

Figure 3-7. Direct Mount Wiring Diagram for 4-Wire Passive Device



NOTE:

A passive loop exists when the wired device is not supplying power to the 4–20 mA loop. It is important to verify if the wired device is operating in active or passive mode.

Figure 3-8. Remote Mount Wiring Diagram for 4-Wire Passive Device

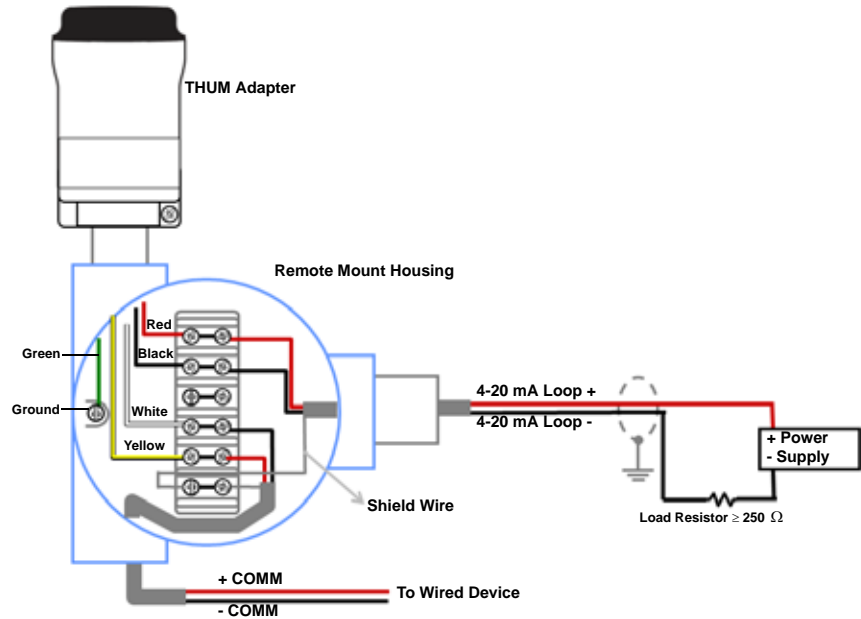

Figure 3-9. Direct Mount Wiring Diagram for 4-Wire Passive Device with Resistor

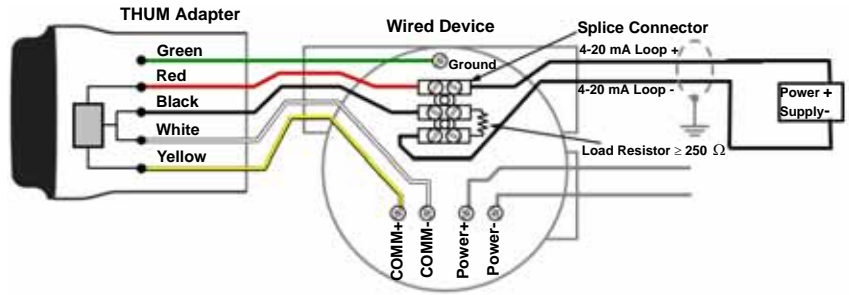
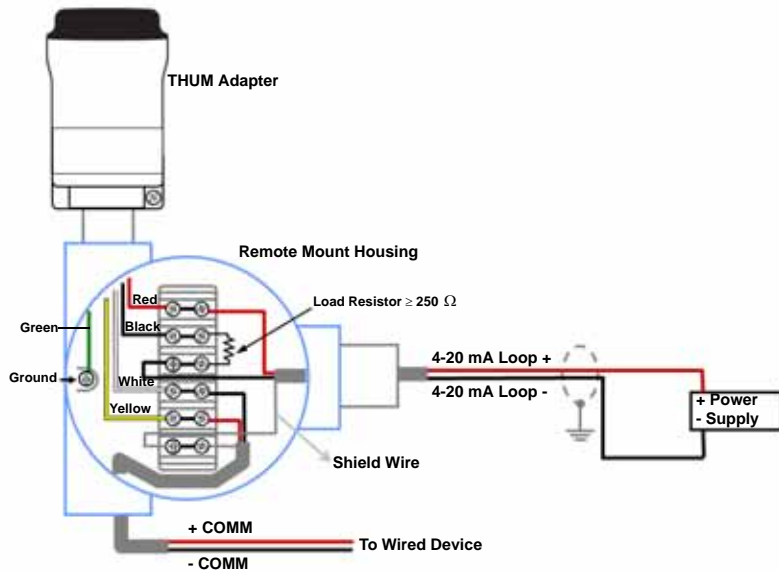
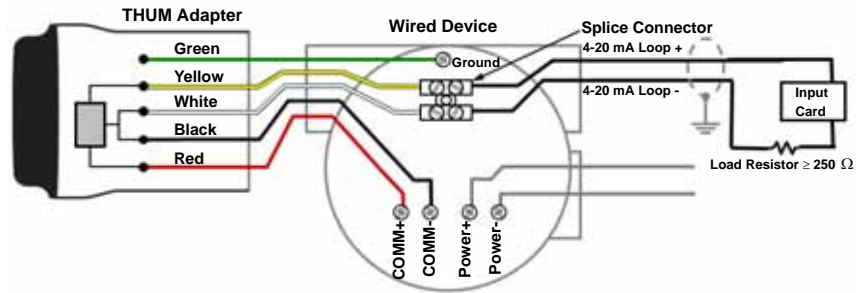

Figure 3-10. Remote Mount Wiring Diagram for 4-Wire Passive Device with Resistor



Smart Wireless THUM Adapter

Figure 3-11. Direct Mount Wiring Diagram for 4-Wire Active Device



NOTE:

An active loop exists when the wired device is supplying the power to the 4-20 mA loop. It is important to verify if the wired device is operating in active or passive mode.

Figure 3-12. Remote Mount Wiring Diagram for 4-Wire Active Device

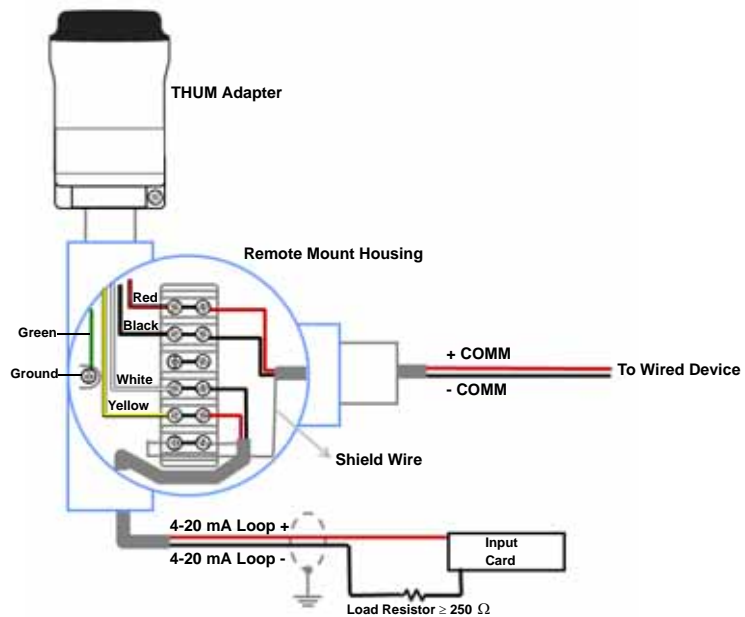

Figure 3-13. Direct Mount Wiring Diagram for 4-Wire Active Device with Resistor

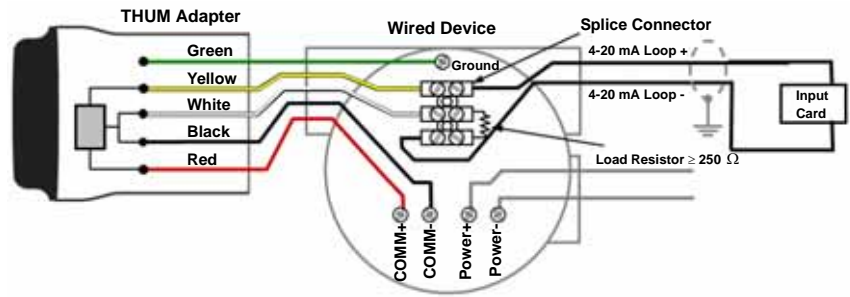
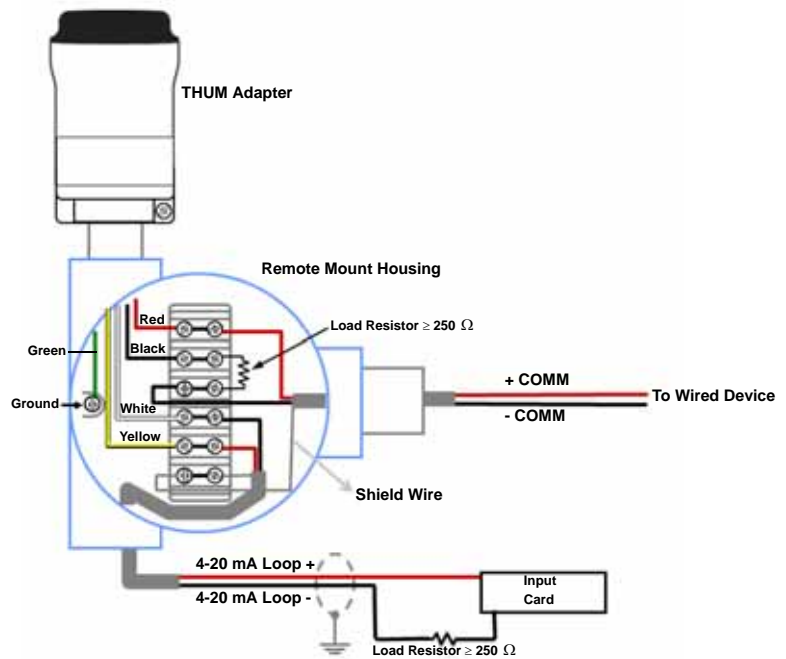

Figure 3-14. Remote Mount Wiring Diagram for 4-Wire Active Device with Resistor



Smart Wireless THUM Adapter

Figure 3-15. Direct Mount Wiring Diagram for 4-Wire Active Device with No 4-20 mA Loop

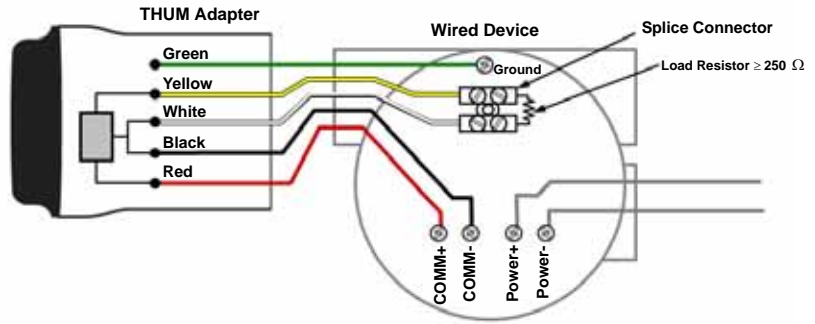
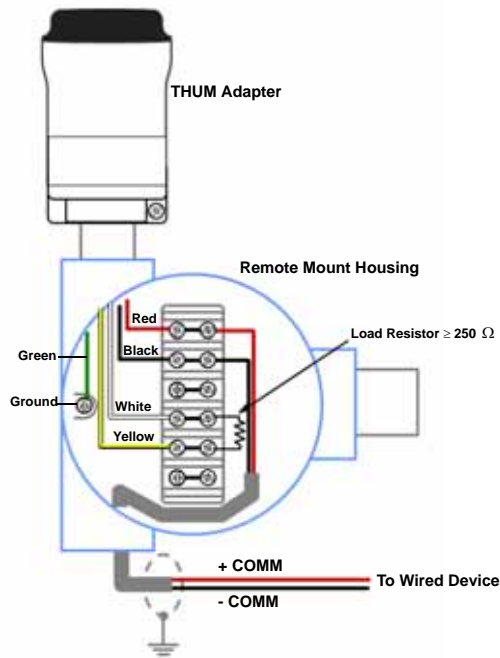

Figure 3-16. Remote Mount Wiring Diagram for 4-Wire Active Device with No 4-20 mA Loop



Reference Manual

00809-0100-4075, Rev BA

October 2010

Smart Wireless THUM Adapter

Figure 3-17. THUM Adapter only, Powered by a 24 V Power Supply with 1200 Ohm resistor to limit current to 20 mA

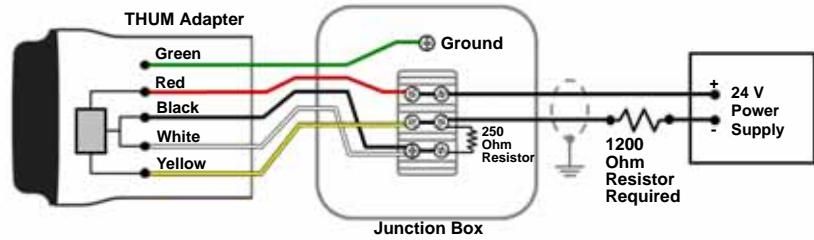

Figure 3-18. THUM Adapter only, Powered by a 24 V Power Supply with 1200 Ohm resistor to limit current to 20 mA

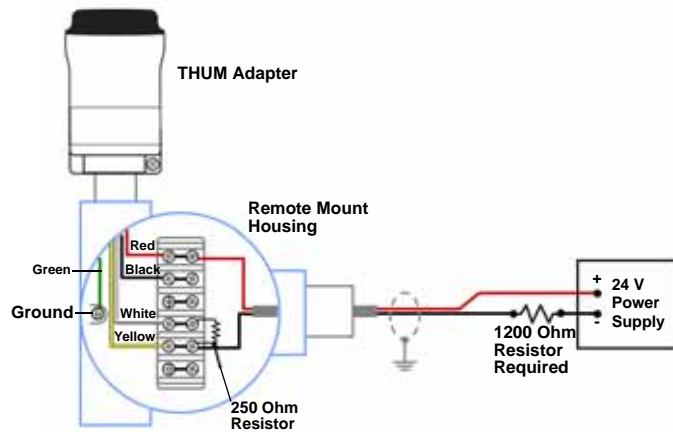
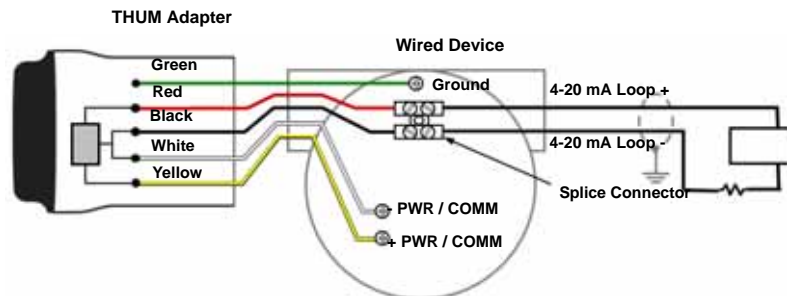
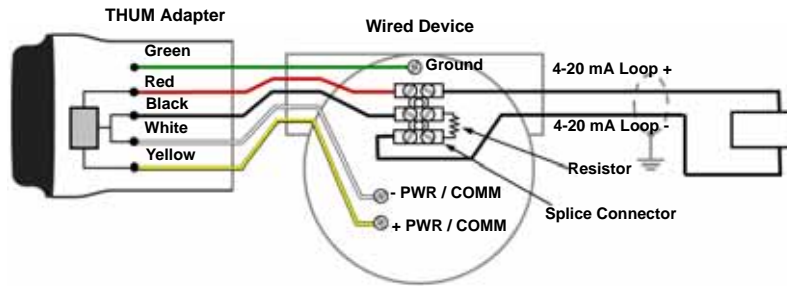

Figure 3-19. Wiring Diagram for 2-Wire Device



Smart Wireless THUM Adapter

Figure 3-20. Wiring Diagram for 2-Wire Device with Resistor



NOTE

A passive loop exists when the wired device is not supplying power to the 4-20 loop. It is important to verify if the wired device is operating in active or passive mode.

Figure 3-21. Wiring Diagram for 4-Wire Passive Device

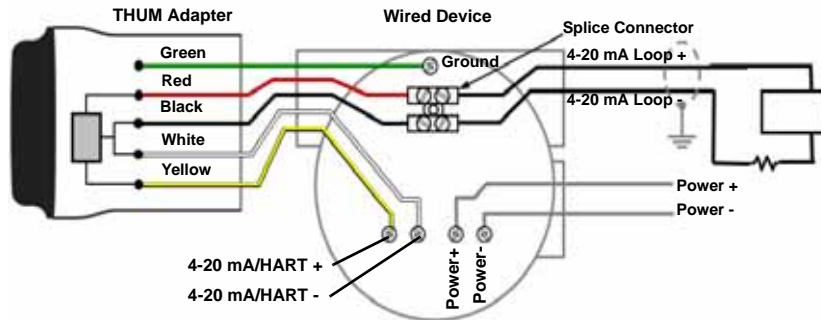
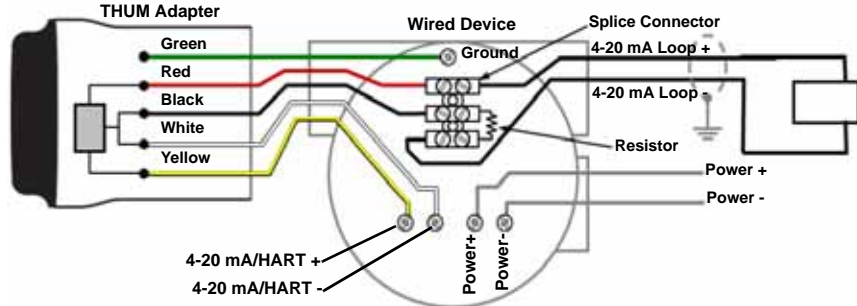

Figure 3-22. Wiring Diagram for 4-Wire Passive Device with Resistor



NOTE

An active loop exists when the wired device is supplying power to the 4-20 mA loop. It is important to verify if the wired device is operating in an active or passive mode.

Figure 3-23. Wiring Diagram for 4-Wire Active Device

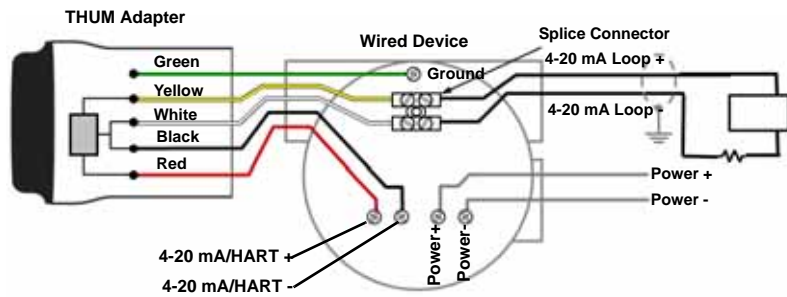

Figure 3-24. Wiring Diagram for 4-Wire Active Device with Resistor

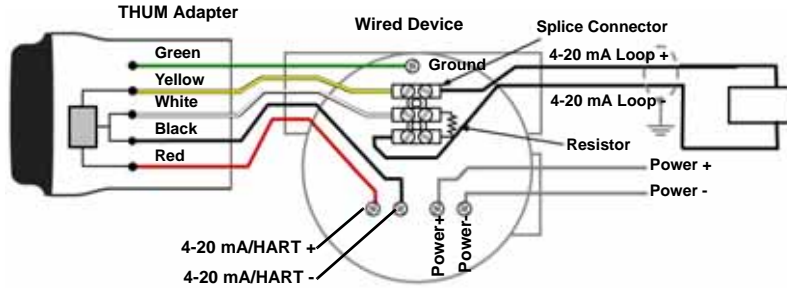
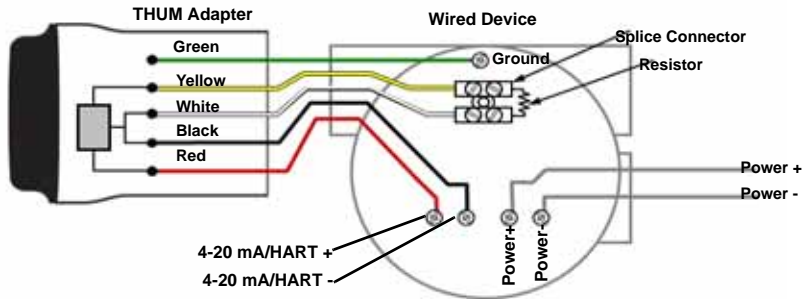
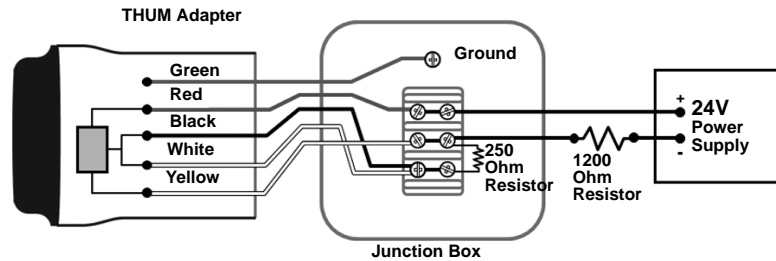

Figure 3-25. Wiring Diagram for 4-Wire Active Device with No 4-20 mA Loop



Smart Wireless THUM Adapter

Figure 3-26. Wiring Diagram for THUM Adapter as Router, no wired device



The 1200 Ohm resistor should be adequately rated for the application (3W minimum).

LOOP CURRENT TEST

To verify that the THUM Adapter will work under all conditions, a loop current test should be performed. This test will exercise the loop under the highest possible voltage drop conditions.

1. Place loop in manual control.
2. Drive loop to high alarm level. For details see wired device instruction manual.
 - When the THUM Adapter is connected to a valve, this will need to be done at the current source and not from the valve.
 - When the THUM Adapter is connected to a transmitter, this will need to be performed at the transmitter.
3. Place the THUM Adapter into fixed voltage drop mode.

AMS

Right click on the THUM Adapter and select **Configure**. When the menu opens, select **Manual Setup** from the window on the left and select the *Wired Device* tab on the top. Make sure that the *Time* drop down menu at the bottom of the page has **Current** selected. Under the *Voltage Drop* drop down menu in the *Smart Power Options* box, select **Fixed Voltage Drop**. Hit the **Apply** button to make any changes. See Figure 3-27 on page 3-15.

Field Communicator

When communicating to the THUM Adapter select: **Configure - Manual setup - Wired Device - Voltage Drop Mode**. In the method choose **Fixed Voltage Drop**.

| Function | Key Sequence | Menu Items |
|--------------|--------------|--------------|
| Voltage Drop | 2,2,2,2 | Voltage Drop |

4. Verify that the current on the loop reaches the high alarm levels.
5. Place the THUM Adapter into variable voltage drop mode.

AMS

Right click on the THUM Adapter and select **Configure**. When the menu opens, select **Manual Setup** from the window on the left and select the *Wired Device* tab on the top. Make sure that the *Time* drop down menu at the bottom of the page has **Current** selected. Under the *Voltage Drop* drop down menu in the *Smart Power Options* box, select **Variable Voltage Drop**. Hit the **Apply** button to make any changes. See Figure 3-27.

Field Communicator

When communicating to the THUM Adapter select: **Configure - Manual setup - Wired Device - Voltage Drop Mode**. In the method choose **Variable Voltage Drop**.

| Function | Key Sequence | Menu Items |
|--------------|--------------|--------------|
| Voltage Drop | 2,2,2,2 | Voltage Drop |

- Remove loop from high alarm value.

Figure 3-27. AMS Configure screen

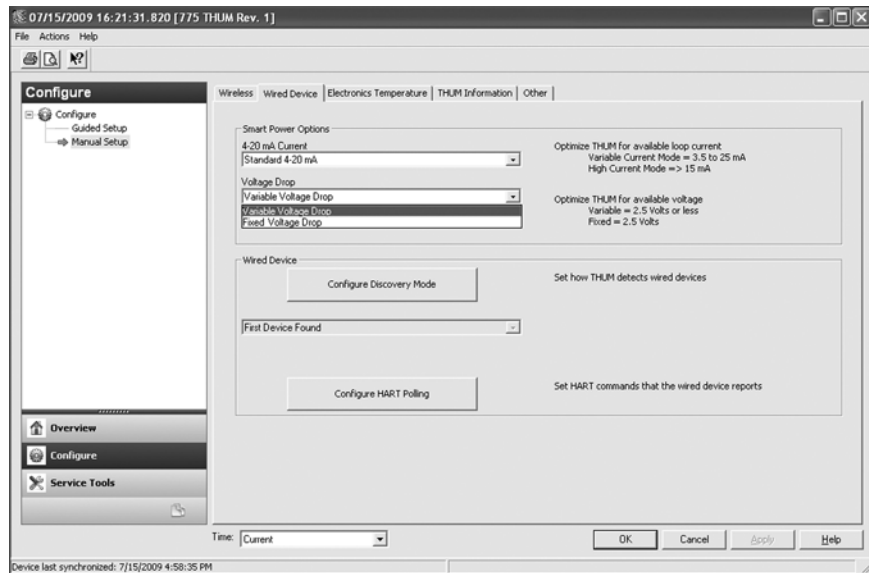

Smart Wireless THUM Adapter

Section 4 Commissioning

| | |
|------------------------------------|----------|
| Safety Messages | page 4-1 |
| Device Network Configuration | page 4-2 |

SAFETY MESSAGES

Instructions and procedures in this section may require special precautions to ensure the safety of the personnel performing the operations. Information that potentially raises safety issues is indicated by a warning symbol () . Please refer to the following safety messages before performing an operation preceded by this symbol.

Warnings

 WARNING

Failure to follow these installation guidelines could result in death or serious injury:

- Only qualified personnel should perform the installation

Explosions could result in death or serious injury.

- Before connecting a Field Communicator in an explosive atmosphere, make sure that the instruments are installed in accordance with intrinsically safe or non-incendive field wiring practices
- Verify that the operating atmosphere of the transmitter is consistent with the appropriate hazardous locations certifications

Electrical shock could cause death or serious injury.

- Use extreme caution when making contact with the leads and terminals

This device complies with Part 15 of the FCC Rules. Operation is subject to the following conditions: This device may not cause harmful interference. This device must accept any interference received, including interference that may cause undesired operation.

This device must be installed to ensure a minimum antenna separation distance of 20 cm from all persons.

Smart Wireless THUM Adapter

DEVICE NETWORK CONFIGURATION

In order to communicate with the Smart Wireless Gateway, and ultimately the Information System, the transmitter must be configured to communicate with the wireless network. This step is the wireless equivalent of connecting wires from a transmitter to the information system. Using a Field Communicator or AMS, enter the Network ID and Join Key so that they match the **Network ID and Join Key** of the gateway and other devices in the network. If the Network ID and Join Key are not identical, the THUM Adapter will not communicate with the network. The Network ID and Join Key may be obtained from the Smart Wireless Gateway on the **Setup>Network>Settings** page on the web server, shown in Figure 4-1.

Figure 4-1. Gateway Network Settings

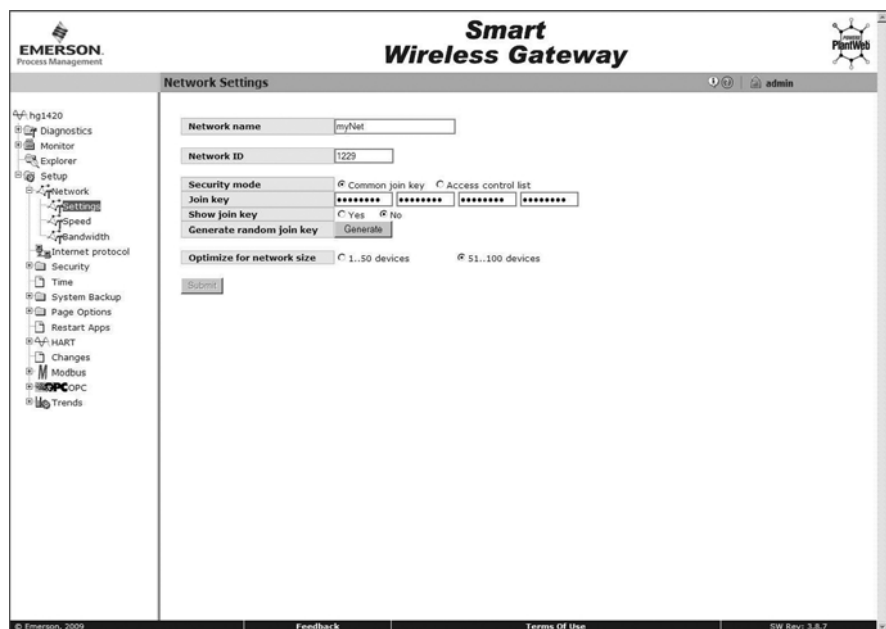

AMS

Right click on the THUM Adapter and select **Configure**. When the menu opens, select **Join Device to Network** and follow the method to enter the Network ID and Join Key.

Field Communicator

The Network ID and Join Key may be changed in the wireless device by using the following Fast Key sequence. Set both Network ID and Join Key.

Operation can be verified in three locations: by using the Field Communicator, at the Gateway via the Smart Wireless Gateway's integrated web server, or via AMS™ Wireless Configurator.

| Function | Key Sequence | Menu Items |
|----------------|--------------|---|
| Wireless Setup | 1,4 | Smart Power, Network ID, Set Join Key, Radio State |

Network Status

If the THUM Adapter was configured with the Network ID and Join Key and sufficient time for network polling has passed, the transmitter should be connected to the network. To verify connectivity, open the Smart Wireless Gateway's integral web interface and navigate to the Explorer page.

The screenshot shows the 'Smart Wireless Gateway' Explorer page. On the left is a navigation menu with options: Diagnostics, Network, Advanced, Monitor, Explorer (selected), and Setup. The main area displays a table with the following data:

| HART Tag | HART status | Last update | PV | SV | TV | QV | Burst rate |
|-------------------|-------------|-------------------|-------------|----------|-------------|------------|------------|
| 5400-1004580 | ● | 08/18/09 15:36:16 | 60.380 ft | 5.236 ft | 23.703 DegC | 756.831 mV | 00:01:00 |
| 5400-1004580-THUM | ● | 08/18/09 15:36:16 | 23.063 DegC | | | | 00:01:00 |

This page will display the THUM Adapter's HART tag, PV, SV, TV, QV, and Update Rate. A green status indicator means that the device is working properly. A red indicator means that there is a problem with either the device or its communication path. For more detail on a specific device, click on the tag name.

Verify Operation

Operation can be verified in three locations: by using the 375 Field Communicator, at the Gateway via the Smart Wireless Gateway's integrated web server, or via AMS™ Wireless Configurator.

Field Communicator

In order for the THUM adapter to communicate with a Field Communicator, a THUM adapter DD is required. The Field Communicator must be put into a polling mode using the THUM adapter address of 63. Connect the Field Communicator to the wired device. The Field Communicator should find both the THUM adapter and the wired device.

Field Communicator Connections

| Function | Key Sequence | Menu Items |
|----------------|--------------|---|
| Communications | 3, 3 | Join Status, Wireless Mode, Join Mode, Number of Available Neighbors, Number of Advertisements Heard, Number of Join Attempts |

Smart Wireless Gateway

If the THUM Adapter was configured with the Network ID and Join Key, and sufficient time has passed for network polling, the transmitter will be connected to the network. To verify device operation and connection to the network with the Smart Wireless Gateway's integrated web server, open the Smart Wireless Gateway's integral web interface and navigate to the **Explorer** page.

NOTE:

It may take several minutes for the device to join the network.

AMS Wireless Configurator

When the device has joined the network, it will appear in the Wireless Configurator as illustrated below.

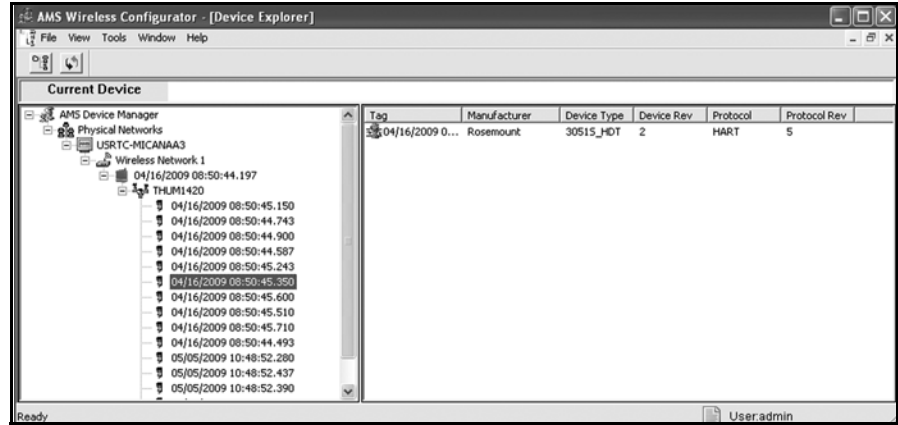

Troubleshooting

If the device is not operating properly, refer to the troubleshooting section of the manual. The most common cause of incorrect operation is the Network ID and Join Key. The Network ID and Join Key in the device must match that of the Smart Wireless Gateway.

The Network ID and Join Key may be obtained from the Smart Wireless Gateway on the **Setup>Network>Settings** page on the web server. The Network ID and Join Key may be changed in the wireless device by using the following Fast Key sequence.

Reference Information

| Function | Key Sequence | Menu Items |
|----------------|--------------|---|
| Wireless Setup | 1, 4 | Smart Power, Network ID, Set Join Key, Radio State |

NOTE

In order to communicate with a Field Communicator, the wired device must be powered.

Table 4-1. THUM Adapter HART Fast Key Sequence

| Function | Key Sequence | Menu Items |
|--------------|--------------|---|
| Device Info | 2, 2, 4, 3 | Manufacturer, Model, Final Assembly Number, Universal, Field Device, Software, Hardware, Descriptor, Message, Date, Model Number I, II, III, SI Unit Restriction, Country |
| Guided Setup | 2, 1 | Configure, Guided Setup, Join Device to Network, Configure Update Rate, Zero Trim, Configure Device Display, Configure Process Alarms |
| Manual Setup | 2, 2 | Configure, Manual Setup, Wireless, Pressure, Device Temperatures, Device Information, Display, Other |
| Wireless | 2, 2, 1 | Network ID, Join Device to Network, Configure Update Rate, Configure Broadcast Power Level, Power Mode, Power Source |

Section 5 Operation and Maintenance

| | |
|-------------------------------|-----------------|
| Safety Messages | page 5-1 |
| Startup Sequence | page 5-2 |
| Advanced Setup | page 5-2 |

SAFETY MESSAGES

Instructions and procedures in this section may require special precautions to ensure the safety of the personnel performing the operations. Information that potentially raises safety issues is indicated by a warning symbol (⚠). Please refer to the following safety messages before performing an operation preceded by this symbol.

Warnings

| ⚠ WARNING |
|--|
| <p>Failure to follow these installation guidelines could result in death or serious injury:</p> <ul style="list-style-type: none">• Only qualified personnel should perform the installation |
| <p>Explosions could result in death or serious injury.</p> <ul style="list-style-type: none">• Before connecting a Field Communicator in an explosive atmosphere, make sure that the instruments are installed in accordance with intrinsically safe or non-incendive field wiring practices• Verify that the operating atmosphere of the transmitter is consistent with the appropriate hazardous locations certifications |
| <p>Electrical shock could cause death or serious injury.</p> <ul style="list-style-type: none">• Use extreme caution when making contact with the leads and terminals |
| <p>This device complies with Part 15 of the FCC Rules. Operation is subject to the following conditions: This device may not cause harmful interference. This device must accept any interference received, including interference that may cause undesired operation.</p> |
| <p>This device must be installed to ensure a minimum antenna separation distance of 20 cm from all persons.</p> |

Smart Wireless THUM Adapter

STARTUP SEQUENCE

Because the THUM is a power scavenging device, different capabilities are available at different times after startup. Configuration is available immediately after startup and includes Update Rate and Discovery method. All network settings including Network ID, Join Key can not be set until the radio is completely initialized. This may take up to three (3) minutes after startup.

After this amount of time has passed, the THUM adapter will start to join the network. Time to join the network depends on network size and number of devices and if active advertising is turned on in the Gateway. After sufficient time to join has passed go to the Explorer page on the Smart Wireless Gateway to see if the THUM has joined.

ADVANCED SETUP

Configure Advanced Update Rate

| | |
|-----------|-----------|
| Fast Keys | 2, 2, 1,3 |
|-----------|-----------|

The “Configure Update Rate” method sets all three update rates based on one user input. The “configure Advanced Update Rate” method allows for each update rate to be set independently of the other two. Values for all update rates are between 8 seconds and 60 minutes. Only one update rate can be set to 8 seconds.

In AMS Select **Manual Setup** and then the **Wireless** tab.

4-20 mA Current

| | |
|-----------|-----------|
| Fast Keys | 2, 2, 2,1 |
|-----------|-----------|

This optimizes the THUM Adapter to the available loop current.

There are two options “Variable Current Mode” and “Fixed Current Mode”. Variable current mode is the default mode and is used when the current on the loop is changing between 3.5 mA to 25 mA.

Fixed Current mode is user selectable. This mode is for when the current on the loop is fixed and will not drop below 15 mA. If the current drops below 15 mA when the THUM Adapter is in fixed current mode, there may be issues with network traffic, and the THUM Adapter may drop off of the wireless network. The HART loop will not be affected.

In AMS Select **Manual Setup** and then the **Wired Device** tab.

Voltage Drop

| | |
|-----------|-----------|
| Fast Keys | 2, 2, 2,2 |
|-----------|-----------|

This optimizes the THUM Adapter to the available voltage on the loop. There are two options: Variable and Fixed. Variable is the default mode. In Variable mode the THUM drops between 2.25 V at 3.5 mA and 1.2 V at 25 mA. In Fixed mode the THUM will always drop 2.25 volts. Fixed mode is used for verifying that there is enough voltage on the loop in the loop check procedure.

In AMS Select **Manual Setup** and then the **Wired Device** tab.

Discovery Mode

| | |
|-----------|-----------|
| Fast Keys | 2, 2, 2,3 |
|-----------|-----------|

The discovery mode is how the THUM Adapter determines which wired device it will update for. There are 3 modes “First Device Found”, “Fixed Polling Address”, and “Fixed Mapping”. The default mode is First Device Found. In First Device Found Mode, the THUM Adapter will update for the first wired device that it finds on the wired bus. This mode is best used when there is only one device on the wired bus. If more than one wired device is found, the THUM Adapter will go into alert.

In Fixed Polling Address mode, the THUM will only update for a wired device at specific HART polling address. Any address can be entered. If no device is found at this address, the THUM Adapter will go into an alarm state.

In Fixed Mapping mode, the user selects the long tag from a list of devices that are currently on the wired bus. If the selected device goes off line, the THUM will not start updating new device, and will go into an alarm state.

In AMS Select **Manual Setup** and then the **Wired Device** tab.

Configure HART Polling

| | |
|-----------|-----------|
| Fast Keys | 2, 2, 2,4 |
|-----------|-----------|

The Configure HART Polling method allows the user to select which commands the THUM Adapter will update for the wired device. The user can select from pre setup information or select custom and enter the HART command that they would like to have the THUM Adapter update for the wired device.

In AMS Select **Manual Setup** and then the **Wired Device**.

Configure Router Only Mode

| | |
|-----------|-----------|
| Fast Keys | 2, 2, 5,2 |
|-----------|-----------|

This mode will set the THUM Adapter up as a router only device. The THUM Adapter will no longer look for wired devices or update for any wired device that is on the HART loop. The THUM Adapter will continue to send updates for itself and will also act as a wireless node in the wireless network.

In AMS Select **Manual Setup** and then the **Other** tab.

HART Address

| | |
|-----------|-----------|
| Fast Keys | 2, 2, 5,3 |
|-----------|-----------|

This is the HART Polling address of the THUM adapter. This can be changed from 0 to 63. This is used when using wired HART communication to talk with the THUM. The THUM Adapter default HART polling address is 63.

In AMS Select **Manual Setup** and then the **Other** tab.

HART Master

| | |
|-----------|-----------|
| Fast Keys | 2, 2, 5,4 |
|-----------|-----------|

Here is where the user can set the THUM Adapter to either a primary or secondary HART master. The THUM is set to primary as default, if another primary master is on the HART loop it may be necessary to change the THUM Adapter to a secondary master. This will not affect the functionality of the THUM Adapter. The number of retries can be set to between 2 and 5.

In AMS Select **Manual Setup** and then the **Other** tab.

Smart Wireless THUM Adapter

Reference Manual
00809-0100-4075, Rev BA
October 2010

Section 6 Troubleshooting

| | |
|---|----------|
| Overview | page 6-1 |
| Troubleshooting Recommended Actions | page 6-2 |

OVERVIEW

Table 6-1 on page 6-2 provides summarized maintenance and troubleshooting suggestions for the most common operating problems.

If you suspect malfunction despite the absence of any diagnostic messages on the Field Communicator display, follow the procedures described here to verify that transmitter hardware and process connections are in good working order. Always deal with the most likely checkpoints first.

Warnings

WARNING

Failure to follow these installation guidelines could result in death or serious injury:

- Only qualified personnel should perform the installation

Explosions could result in death or serious injury.

- Before connecting a Field Communicator in an explosive atmosphere, make sure that the instruments are installed in accordance with intrinsically safe or non-incendive field wiring practices
- Verify that the operating atmosphere of the transmitter is consistent with the appropriate hazardous locations certifications

Electrical shock could cause death or serious injury.

- Use extreme caution when making contact with the leads and terminals

This device complies with Part 15 of the FCC Rules. Operation is subject to the following conditions: This device may not cause harmful interference. This device must accept any interference received, including interference that may cause undesired operation.

This device must be installed to ensure a minimum antenna separation distance of 20 cm from all persons.

Smart Wireless THUM Adapter

Table 6-1. Troubleshooting Recommended Actions

| Symptom | Recommended Action |
|--|---|
| Wired Troubleshooting | |
| Wired device does not turn on when THUM Adapter is added to loop | Check the wiring and connections between THUM Adapter and wired device Verify that enough voltage is being supplied to power both the THUM Adapter and wired device |
| Wired Device does not function properly through loop check | Determine total voltage drop of system assume 2.5 volts for THUM Adapter Verify that enough voltage is on the loop |
| Can not communicate with wired device or THUM Adapter | Verify that wiring is correct Verify that enough voltage is being supplied to power both THUM Adapter and wired device Verify that between 250 and 1100 Ohms resistance is present |
| Can not communicate with THUM Adapter | Verify that wiring is correct Verify that enough voltage is being supplied to power both THUM Adapter and wired device Verify that between 250 and 1100 Ohms resistance is present Verify that Field communicator or AMS is set to poll for THUM Adapter address Power Cycle device to try again |
| Configuration Troubleshooting | |
| Can not configure THUM Adapter with 375 or AMS | Make sure that the correct DD is loaded into the 375 or AMS |
| THUM Adapter does not communicate with wired device | Run the "Configure Discovery Mode" method to connect the THUM Adapter to wired device Check the wiring and connections between THUM Adapter and wired device Verify that between 250 and 1100 Ohms resistance is present for HART communications Verify that the wired device is functioning properly Power Cycle device to try again |
| Duplicate HART Master Detected | Verify that two primary masters are on the loop Then set the THUM Adapter into secondary master mode Power Cycle device to try again If THUM Adapter is in secondary master mode and 375 or AMS is connected to loop this error will occur The error will disappear after the 375 or AMS is removed from the loop. |
| Wireless Network Troubleshooting | |
| THUM Adapter not joining network | Verify network ID and join key Wait longer (30 min.) Verify THUM Adapter is within range of at least one other device Verify network is in active network advertise Power Cycle device to try again Verify device is configured to join. Send the "Force Join" command to the device See troubleshooting section of Smart Wireless Gateway for more information |
| Limited Bandwidth Error | Reduce the Update Rate on THUM Adapter and wired device Increase communication paths by adding more wireless points Check that THUM Adapter has been online for at least an hour Check that THUM Adapter is not routing through a "limited" routing node Create a new network with an additional Smart Wireless Gateway |

Appendix A Reference Data

| | |
|---|----------|
| Functional Specifications | page A-1 |
| Physical Specifications | page A-1 |
| Performance Specifications | page A-2 |
| Dimensional Drawings | page A-3 |
| Ordering Information | page A-5 |

FUNCTIONAL SPECIFICATIONS

Input

Any 2- or 4-wire HART powered device.

Output

IEC 62591 (WirelessHART)

Humidity Limits

0–100% relative humidity

Update Rate

User selectable, 8 sec. to 60 min.

PHYSICAL SPECIFICATIONS

Electrical Connections

The THUM is connected into a powered 4–20 mA loop, powering itself by scavenging power. The THUM causes a voltage drop across the loop. The drop is linear from 2.25 volts at 3.5 mA to 1.2 volts at 25 mA, but does not effect the 4–20 mA signal on the loop. Under fault conditions, the maximum voltage drop is 2.5 volts.

Power Supply

Minimum load on loop 250 Ohms.

To maintain normal operating functions of the sub-device, the power in the loop must have at least a 2.5 V margin at a 250 Ohm load.

Limit power supply to 0.5 Amps maximum.

Limit power supply to 55 Vdc maximum.

Field Communicator Connections

Utilize sub-device HART connections.

Materials of Construction

Housing option D - Low-copper aluminum

Housing option E - 316 SST

Paint - Polyurethane

M20-Conduit Adapter - SST

M20-Conduit Adapter O-ring - Buna-n

Antenna

Poly butadine terephthalate (PBT) / Polycarbonate (PC) integrated omnidirectional antenna

Smart Wireless THUM Adapter

Weight

THUM Adapter only AL - 0.65 lbs. (0.29 kg)

THUM Adapter only SST - 1.1 lbs. (0.5 kg)

AL THUM Adapter with AL remote kit - 3.2 lbs. (1.45 kg)

SST THUM Adapter with SST remote kit - 5.8 lbs. (2.65 kg)

AL THUM Adapter with M20 conduit adapter - 0.85 lbs. (.038 kg)

SST THUM Adapter with M20 conduit adapter - 1.3 lbs. (0.59 kg)

Enclosure Ratings

Housing option code D is NEMA 4X, and IP66.

Mounting

The THUM Adapter may be attached directly to the conduit of any 2- or 4-wire HART device or mounted remotely by using the remote mount kit.

PERFORMANCE SPECIFICATIONS

ElectroMagnetic Compatibility (EMC)

All Models:

Meets all relevant requirements of EN 61326-1 (2006) when installed with shielded wiring. The sub-device must also use shielded wiring for installation.

Vibration Effect

Output unaffected when tested per the requirements of IEC60770-1 field with general application or pipeline with low vibration level (10-60 Hz 0.15 mm displacement peak amplitude / 60-500 Hz 2g).

When the THUM Adapter is used on wired devices that are subject to vibration levels greater than 2g, it is recommended that the THUM Adapter be remotely mounted using the remote mount kit.

Temperature Limits

| Operating Limit | Storage Limit |
|-----------------|---------------|
| -40 to 185 °F | -40 to 185 °F |
| -40 to 85 °C | -40 to 85 °C |

Output Specifications

The THUM allows Wireless communication between the HART device it is connected to and the Smart Wireless Gateway.

DIMENSIONAL DRAWINGS

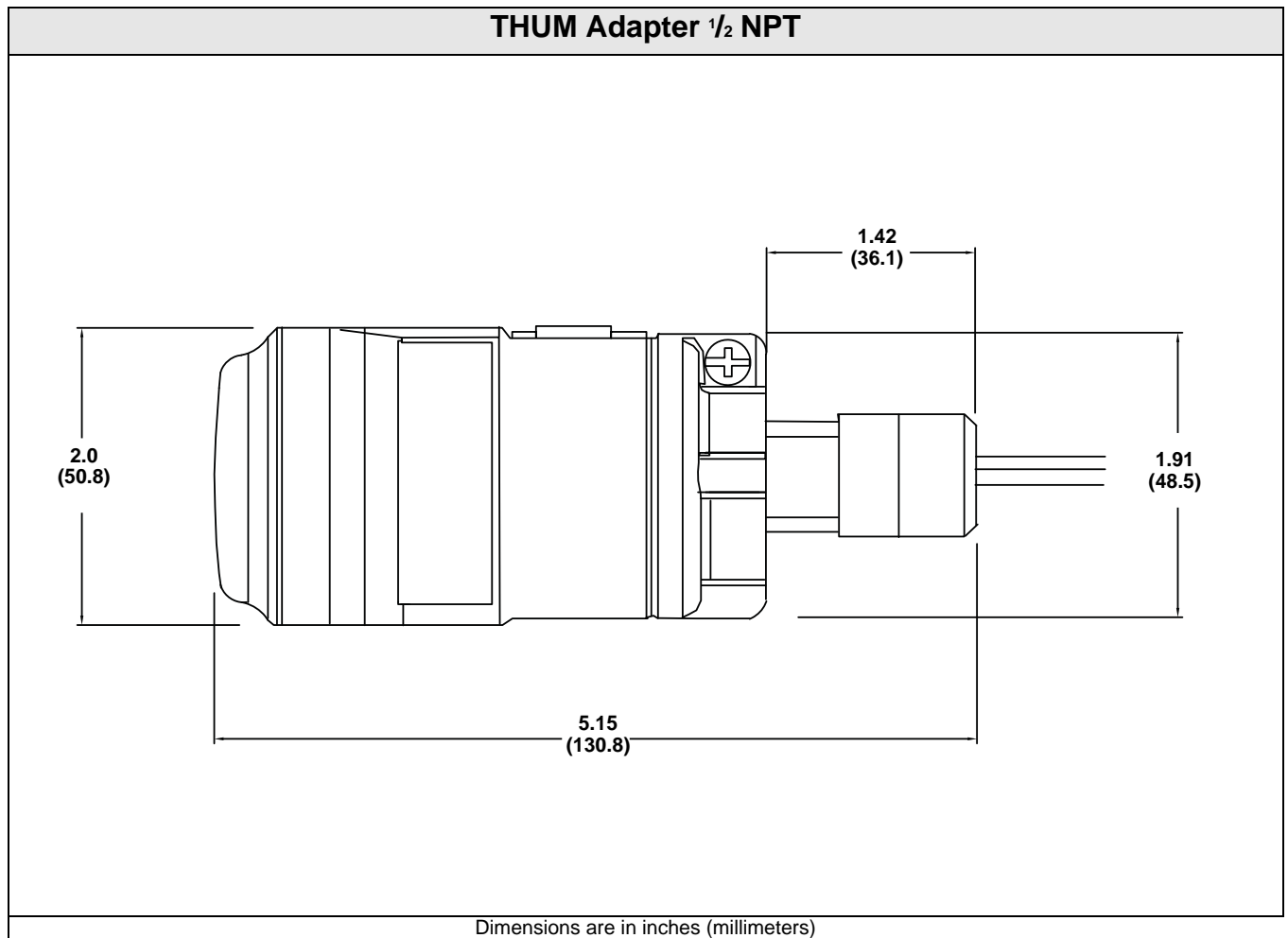

Smart Wireless THUM Adapter

THUM Adapter with M20 Conduit Adapter

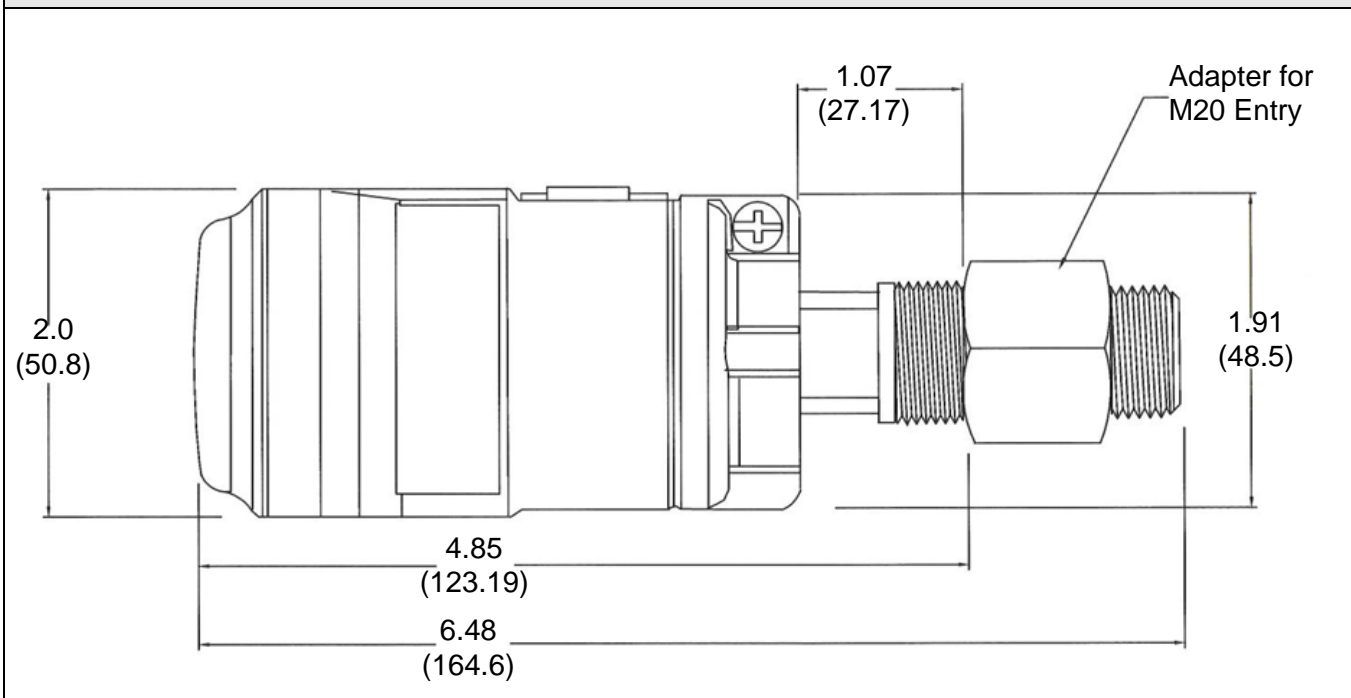

Dimensions are in inches (millimeters)

THUM Adapter with Remote Mount Kit

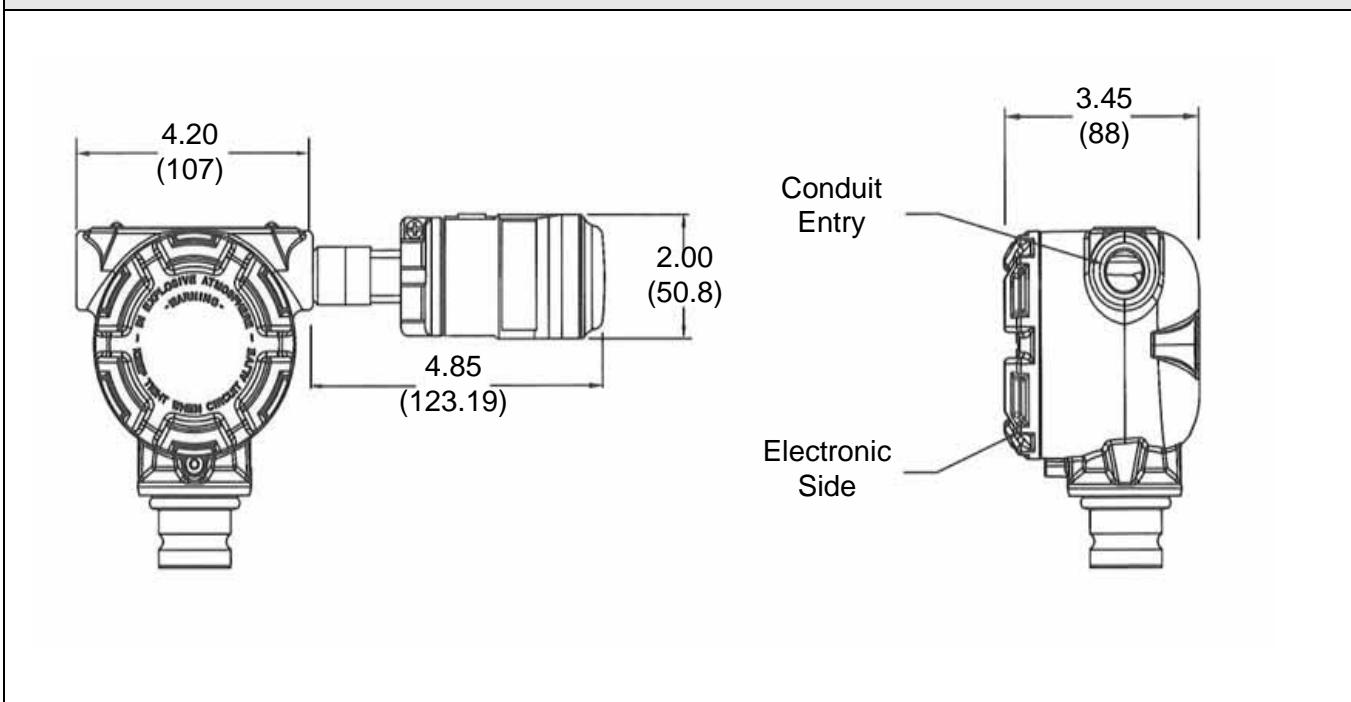

Dimensions are in inches (millimeters)

ORDERING INFORMATION

Table A-1. Smart Wireless THUM Adapter Ordering Information

★ The Standard offering represents the most common options. The starred options (★) should be selected for best delivery.

The Expanded offering is subject to additional delivery lead time.

| Model | Product Description | |
|---|---|-----------------|
| 775 | Smart Wireless THUM Adapter | |
| Output | | |
| X | Wireless | |
| Housing | | |
| Standard | | Standard |
| D | Aluminum | ★ |
| Expanded | | |
| E | SST | |
| Mounting Connection | | |
| Standard | | Standard |
| 1 | 1/2 - 14 NPT | ★ |
| 2 | M20-Conduit Adapter | ★ |
| PlantWeb Functionality | | |
| Standard | | Standard |
| 1 | HART® Data | ★ |
| Certification | | |
| Standard | | Standard |
| NA | No Approval | ★ |
| I5 | FM Intrinsically Safe, Non-incendive | ★ |
| I6 | CSA Intrinsically Safe | ★ |
| I1 | ATEX Intrinsic Safety | ★ |
| N1 | ATEX Type n | ★ |
| I7 | IECEX Intrinsic Safety | ★ |
| N7 | IECEX Type n | ★ |
| I2 | INMETRO Intrinsic Safety | ★ |
| N2 | INMETRO Type n | ★ |
| I3 | China Intrinsic Safety | ★ |
| IP | Korea (KOSHA) Intrinsic Safety | ★ |
| IW | India (CCOE) Intrinsic Safety | ★ |
| IM | GOST (Russia) Intrinsically Safe | ★ |
| Wireless Update Rate, Operating Frequency, and Protocol | | |
| Standard | | Standard |
| WA3 | User Configurable Update Rate, 2.4 GHz DSSS, WirelessHART | ★ |
| Omnidirectional, Wireless Antenna, and SmartPower™ Options | | |
| Standard | | Standard |
| WK9 | Long range, Integral Antenna, Power Scavenging | ★ |
| Typical Model Number: 775XD11I5WA3WK9 | | |

ACCESSORIES AND SPARE PARTS

Table A-2. Accessories

| Item Description | Part Number |
|------------------------|-----------------|
| Remote Mount Kit - AI | 00775-9000-0001 |
| Remote Mount Kit - SST | 00775-9000-0011 |
| M20-Conduit Adapter | 00775-9001-0001 |

Smart Wireless THUM Adapter

Appendix B Product Certifications

| | |
|---|-----------------|
| Approved Manufacturing Locations | page B-1 |
| European Directive Information | page B-1 |
| Telecommunication Compliance | page B-1 |
| FCC and IC | page B-1 |
| Ordinary Location Certification for FM | page B-1 |
| Hazardous Locations Certificates | page B-1 |

Approved Manufacturing Locations

Rosemount Inc. – Chanhassen, Minnesota, USA
Emerson Process Management GmbH & Co. - Karlstein, Germany
Emerson Process Management Asia Pacific Private Limited - Singapore

European Directive Information

The EC declaration of conformity for all applicable European directives for this product can be found at www.rosemount.com. A hard copy may be obtained by contacting an Emerson Process Management representative.

ATEX Directive (94/9/EC)

Emerson Process Management complies with the ATEX Directive.

Electro Magnetic Compatibility (EMC) (2004/108/EC)

Emerson Process Management complies with the EMC Directive.

Radio and Telecommunications Terminal Equipment Directive (R&TTE) (1999/5/EC)

Emerson Process Management complies with the R&TTE Directive.

Telecommunication Compliance

All wireless devices require certification to ensure that they adhere to regulations regarding the use of the RF spectrum. Nearly every country requires this type of product certification. Emerson is working with governmental agencies around the world to supply fully compliant products and remove the risk of violating country directives or laws governing wireless device usage.

FCC and IC

This device complies with Part 15 of the FCC Rules. Operation is subject to the following conditions: This device may not cause harmful interference. This device must accept any interference received, including interference that may cause undesired operation. This device must be installed to ensure a minimum antenna separation distance of 20 cm from all persons.

Ordinary Location Certification for FM

As standard, the transmitter has been examined and tested to determine that the design meets basic electrical, mechanical, and fire protection requirements by FM, a nationally recognized testing laboratory (NRTL) as accredited by the Federal Occupational Safety and Health Administration (OSHA).

Hazardous Locations Certificates

North American Certifications

Factory Mutual (FM) Approvals

- 15** FM Intrinsically Safe and Non-incendive
Intrinsically Safe for Class I/II/III, Division 1, Groups A, B, C, D, E, F, and G.
Zone Marking: Class I, Zone 0, AEx ia IIC
Temperature Codes T4 (-50 °C ≤ T_{amb} ≤ 70 °C)
Non-incendive for Class I, Division 2, Groups A, B, C, and D.
Intrinsically safe and non-incendive when installed according to Rosemount Drawing 00775-0010.
Enclosure Type 4X/IP66

CSA - Canadian Standards Association

- I6** CSA Intrinsically Safe
Intrinsically Safe for Class I, Division 1, Groups A, B, C, and D.
T3C ($-50\text{ }^{\circ}\text{C} \leq T_{\text{amb}} \leq 70\text{ }^{\circ}\text{C}$)
Intrinsically safe when installed according to Rosemount Drawing
00775-0012.
Suitable for Class I, Division 2, Groups A, B, C, and D.
Enclosure Type 4X/IP66

European Certifications

- I1** ATEX Intrinsic Safety
Certificate No.: Baseefa09ATEX0125X Ⓢ II 1G
Ex ia IIC T4 ($-50\text{ }^{\circ}\text{C} \leq T_{\text{amb}} \leq 70\text{ }^{\circ}\text{C}$)
IP66
cE 1180

Table B-1. Input Parameters

| Loop Power |
|-----------------------|
| $U_i = 30\text{ V}$ |
| $I_i = 200\text{ mA}$ |
| $P_i = 1.0\text{ W}$ |
| $C_i = 0$ |
| $L_i = 0$ |

Special conditions for safe use (X)

The surface resistivity of the antenna is greater than one gigaohm. To avoid electrostatic charge build-up, it must not be rubbed or cleaned with solvents or a dry cloth.

The enclosure is made of aluminium alloy and given a protective polyurethane paint finish; however, care should be taken to protect it from impact or abrasion if located in a zone 0.

- N1** ATEX Type n
Certificate No.: Baseefa09ATEX0131 Ⓢ II 3 G
Ex nA IIC T4 ($-50\text{ }^{\circ}\text{C} \leq T_{\text{amb}} \leq 70\text{ }^{\circ}\text{C}$)
 $U_i = 45\text{ Vdc MAX}$
IP66
cE 1180

IECEX Certifications

I7 IECEX Intrinsic Safety

Certificate No.: IECEX BAS 09.0050X

Ex ia IIC T4 (-50 °C ≤ T_{amb} ≤ 70 °C)

IP66

Table 1. Input Parameters

| Loop Power |
|-------------------------|
| U _i = 30 V |
| I _i = 200 mA |
| P _i = 1.0 W |
| C _i = 0 |
| L _i = 0 |

Special conditions for safe use (X)

The surface resistivity of the antenna is greater than one gigaohm. To avoid electrostatic charge build-up, it must not be rubbed or cleaned with solvents or a dry cloth.

The enclosure is made of aluminium alloy and given a protective polyurethane paint finish; however, care should be taken to protect it from impact or abrasion if located in a zone 0.

N7 IECEX Type n

Certificate No.: IECEX BAS 09.0058

Ex nA IIC T4 (-50 °C ≤ T_{amb} ≤ 70 °C)

U_i = 45 Vdc MAX

IP66

INMETRO Certifications

I2 Intrinsic Safety

BR-Ex ia IIC T4 (-50 °C ≤ T_{amb} ≤ 70 °C) Ga

N2 INMETRO Type 'n'

BR-Ex nA IIC T4 Gc (-50 °C ≤ T_{amb} ≤ 70 °C)

China (NEPSI) Certifications

I3 China (NEPSI) Intrinsic Safety

Ex ia IIC T4

CCoE Certifications

IW Intrinsic Safety

Ex ia IIC T4

KOSHA Certifications

IP Intrinsic Safety

Ex ia IIC T4

GOST Certifications

IM Intrinsically Safe

Ex ia IIC T4 (-50 °C ≤ T_{amb} ≤ 70 °C)

Ex nA IIC T4 (-50 °C ≤ T_{amb} ≤ 70 °C)

IP66

Smart Wireless THUM Adapter

Figure B-1. 775 THUM FM I.S. & Class 1, Div. 2 Installation Drawing (1 of 2)

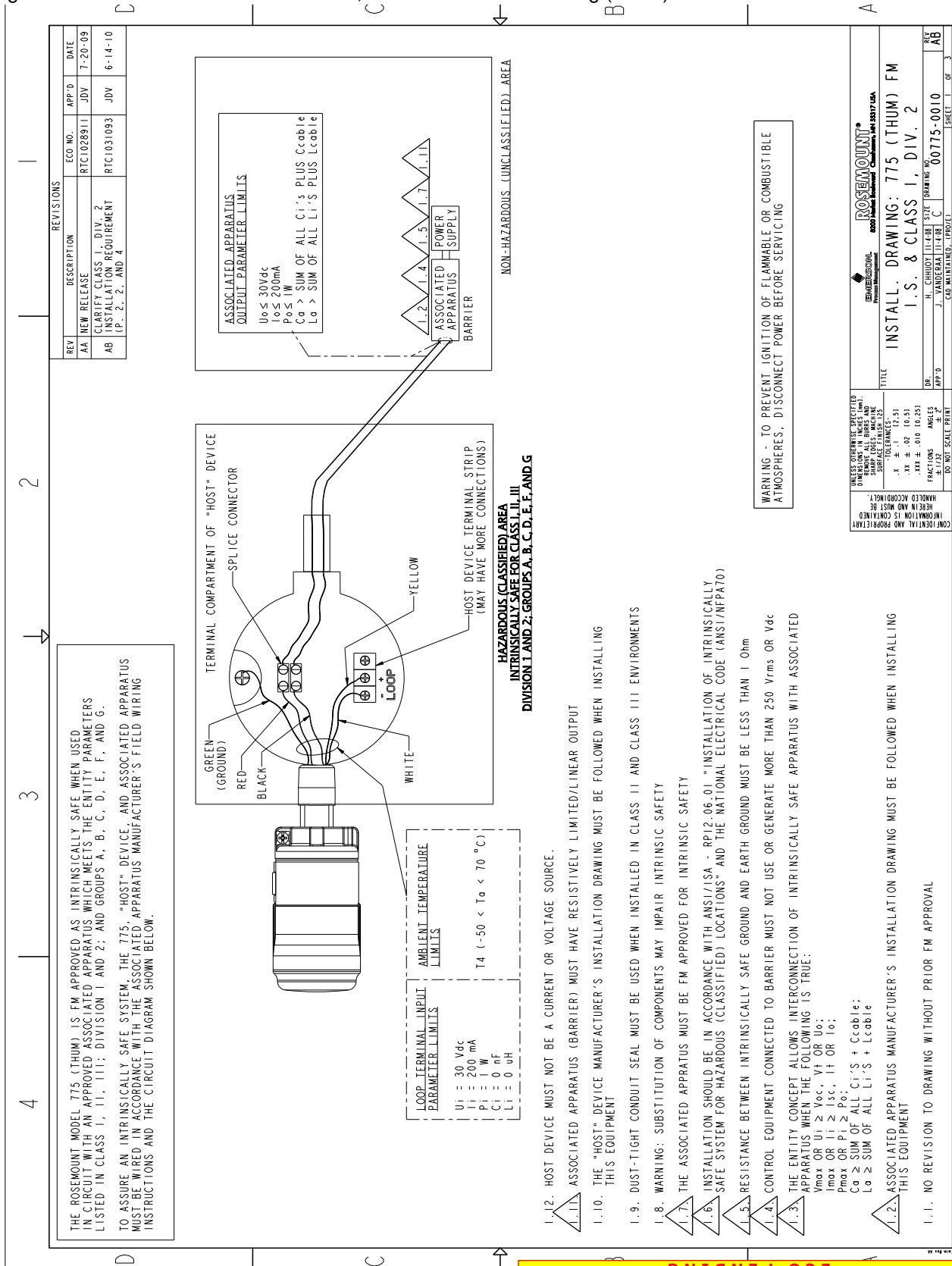
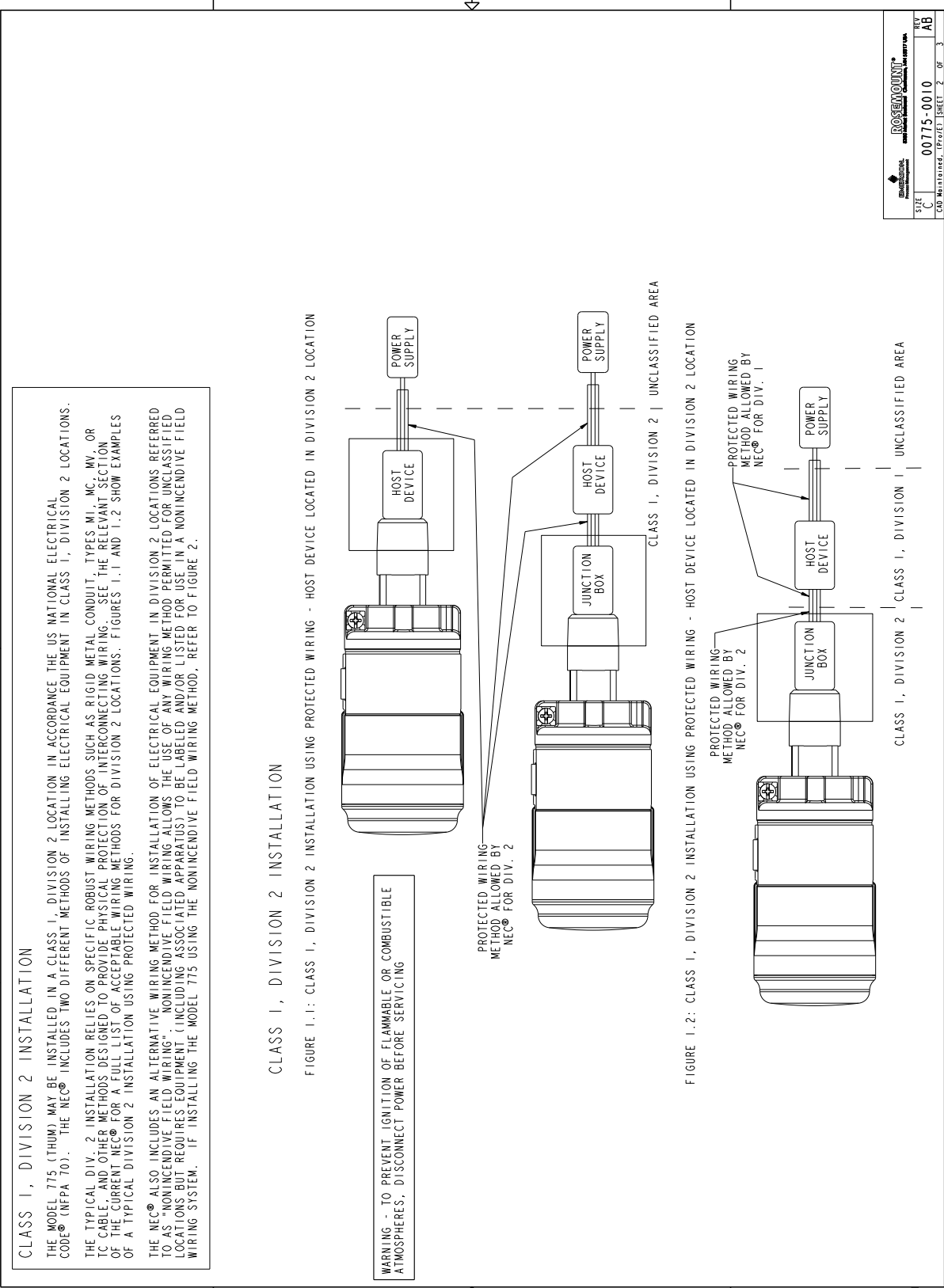

Figure B-2. 775 THUM FM I.S. & Class 1, Div. 2 Installation Drawing (2 of 2)



| | |
|--|------------|
| ROSEMOUNT® INTERNATIONAL | |
| SIZE C | REV AB |
| CAD Maintained... PROJECT SHEET 2 OF 3 | 00775-0010 |

Smart Wireless THUM Adapter

Figure B-3. 775 THUM CSA I.S. Installation drawing

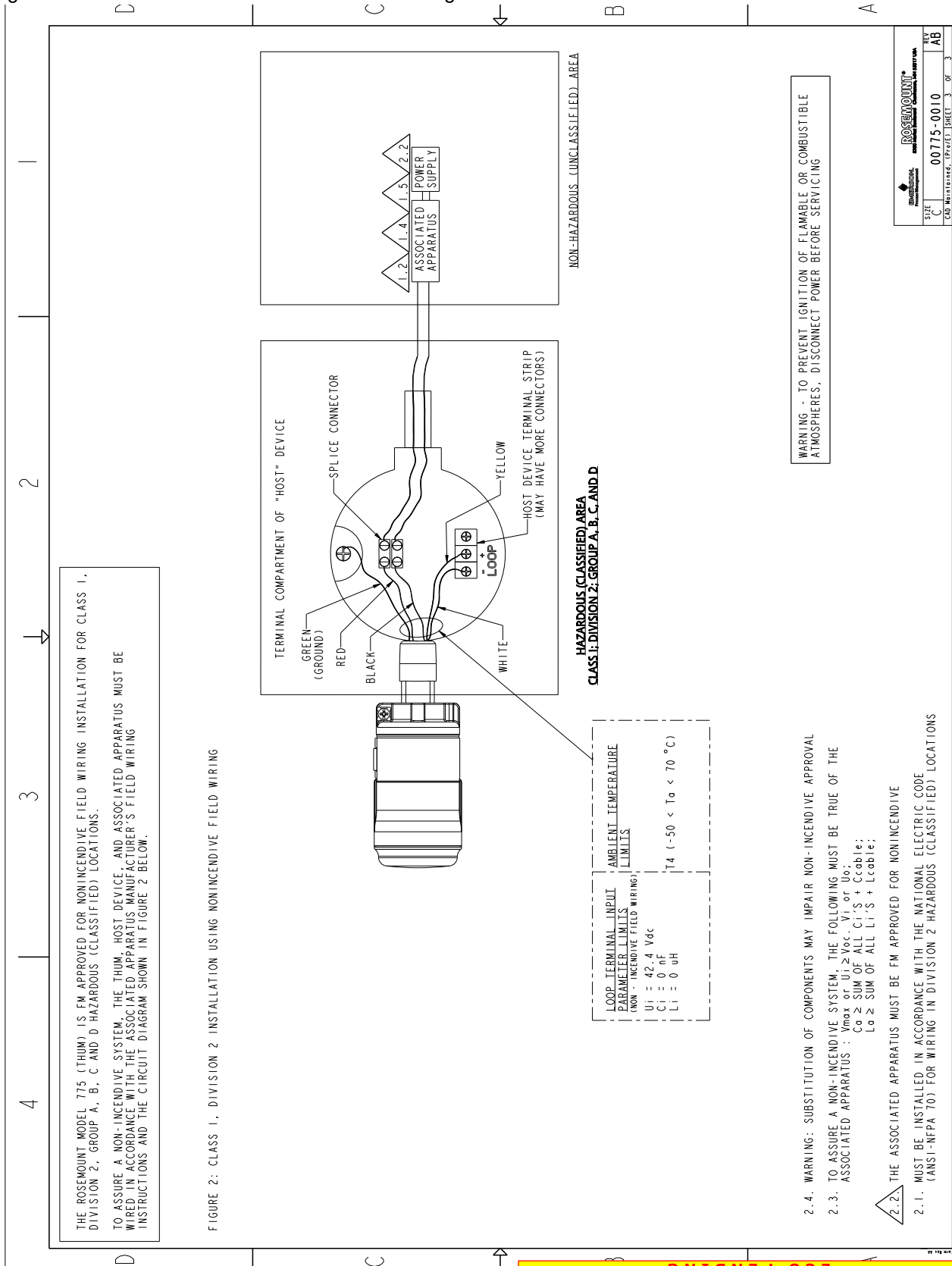
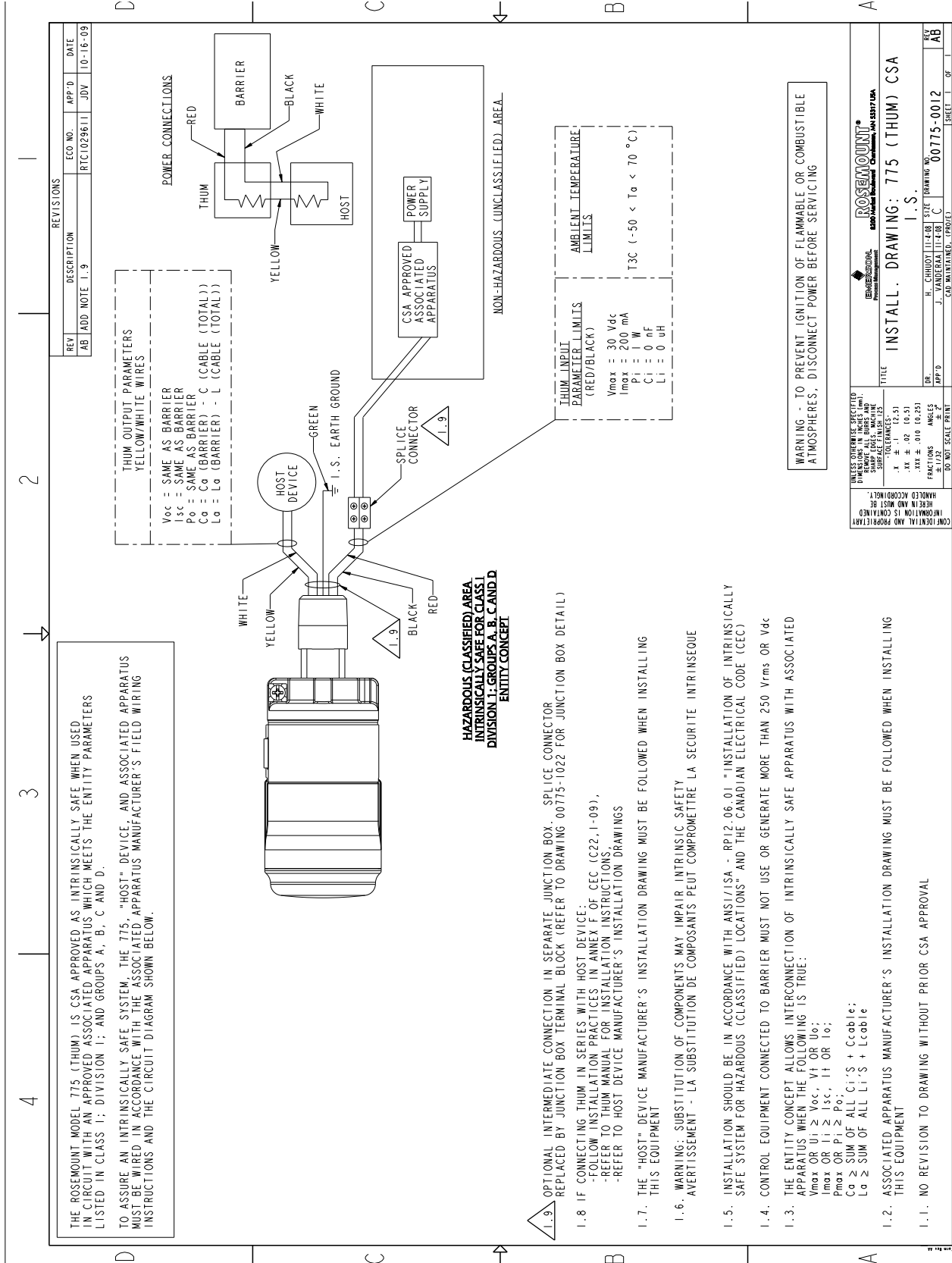

Figure B-4. 775 THUM CSA Installation Drawing



*The Emerson logo is a trade mark and service mark of Emerson Electric Co.
Rosemount and the Rosemount logotype are registered trademarks of Rosemount Inc.
PlantWeb is a registered trademark of one of the Emerson Process Management group of companies.
HART is a registered trademark of the HART Communication Foundation.
Lexan and Noryl are registered trademark of General Electric.
All other marks are the property of their respective owners.*

Standard Terms and Conditions of Sale can be found at www.rosemount.com/terms_of_sale

Emerson Process Management
Rosemount Inc.
8200 Market Boulevard
Chanhassen, MN 55317 USA
T (U.S.) 1-800-999-9307
T (International) (952) 906-8888
F (952) 949-7001

www.rosemount.com

Rosemount Temperature GmbH
Frankenstrasse 21
63791 Karlstein
Germany
T 49 (6188) 992 0
F 49 (6188) 992 112

**Emerson Process Management Asia
Pacific Private Limited**
1 Pandan Crescent
Singapore 128461
T (65) 6777 8211
F (65) 6777 0947
Enquiries@AP.EmersonProcess.com