

Shafer™

Automatic Line Break and Low Pressure Shutoff Control

The most reliable mainline protection is found in the Shafer Automatic Line Break and Low Pressure Shutoff Control.

The redundancy of this control affords rate of pressure drop protection from the Automatic Line Break Control combined with low pressure shutoff protection from the preset pressure sensor.

Should circumstances arise where a break occurs but yet the rate of pressure drop at the sensing point is less than the field adjusted sensitivity of the linebreak control the valve will not be commanded to close. However, with this dual function control, when the mainline pressure drops below a preset minimum operating pressure, the low pressure sensor reacts and commands the valve to close thus isolating the break and avoiding further loss of product and minimizing damage to surrounding property.

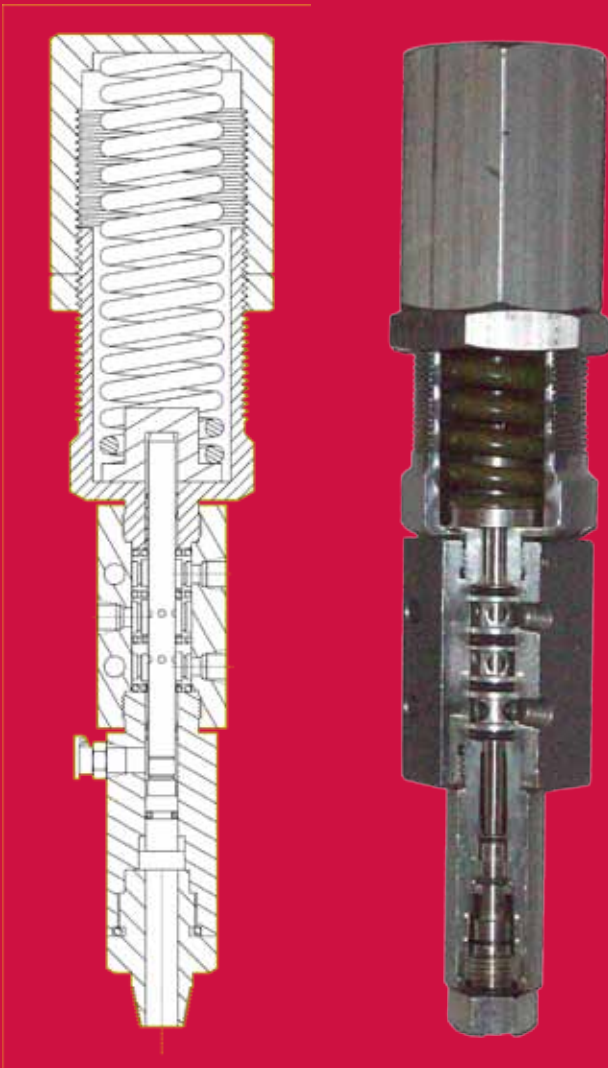

AUTOMATIC LINE BREAK & LOW PRESSURE SHUTOFF CONTROL

The unique Shafer Automatic Linebreak Control operates on a diaphragm, reference and orifice principle to automatically close valves in the event of an excessive sustained drop in pipeline pressure. For detailed operational sequence of this portion of the control refer to Automatic Linebreak Control Bulletin ALB-370.

The low pressure shutoff portion of the control functions as follows:

SEQUENCE 1 - VALVE FULLY OPEN

Control components for the low pressure shutoff function include an adjustable air relay valve (X) and an ESD poppet valve (N).

Pressure from the pipeline is ported to the sensing portion of air relay valve (X) holding it in the open position. By way of the adjustable spring, the low pressure falling trip point is established.

SEQUENCE 2 - VALVE CLOSING

If the mainline pressure falls below the set point pressure of the air relay valve (X), the valve shifts to the closed position which vents the pilot pressure from the front side of piston (O) on ESD poppet valve (N), shifting poppet (Q), blocking the exhaust port and allowing power gas to shift shuttle valve (M) which isolates the secondary control (A). Power gas pressurizes the closing gas hydraulic tank (K), forcing high pressure hydraulic fluid into the operator causing the valve operator to close quickly. The resident fluid in the operator is forced into the opening tank (L). As the valve and shuttle valve (W) shifts and selects the high pressure side of the valve as a power source for the operator.

SEQUENCE 3 - VALVE FULLY CLOSED

When the valve operator reaches the end of stroke, the mechanical actuator (R), which is attached to the operator rotor, mechanically closes the ESD poppet valve (N) forcing the poppet (Q) into the power seat, allowing the gas hydraulic tank and operator pressures to neutralize. The operator is now in emergency failed position. The valve remains closed, isolating the affected pipeline section permitting repairs to be made. The valve operator can only be opened after the pipeline pressure has risen high enough to trip the air relay valve (X) open. This pressurizes the pilot of ESD poppet valve (N) and mechanical actuator (R) is no longer required to hold the ESD poppet valve (N) closed. The valve operator can be opened by using poppet control (A) or manually hand-pumping.

www.EmersonProcess.com/Shaffer

Shafer

2500 Park Ave. West
Mansfield, OH 44906
Phone (419) 529-4311, FAX (419) 529-3688

info.Mansfield@EmersonProcess.com

Shafer™

Bulletin HP-240-00299

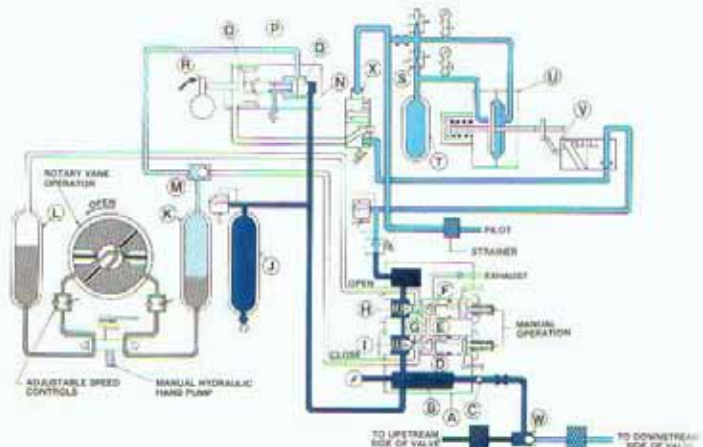
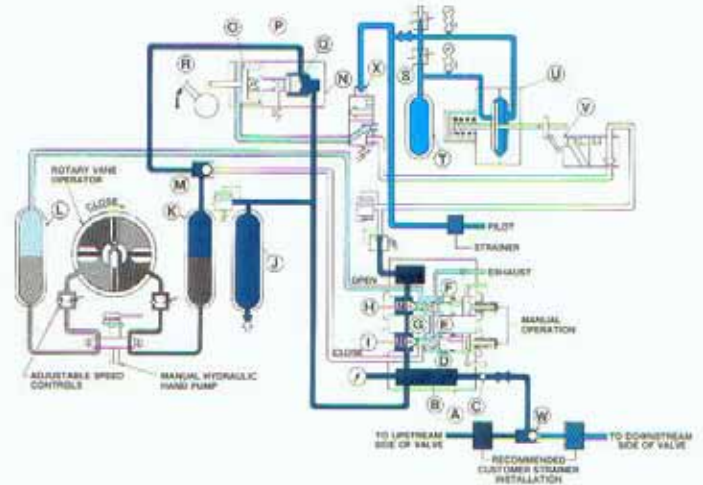
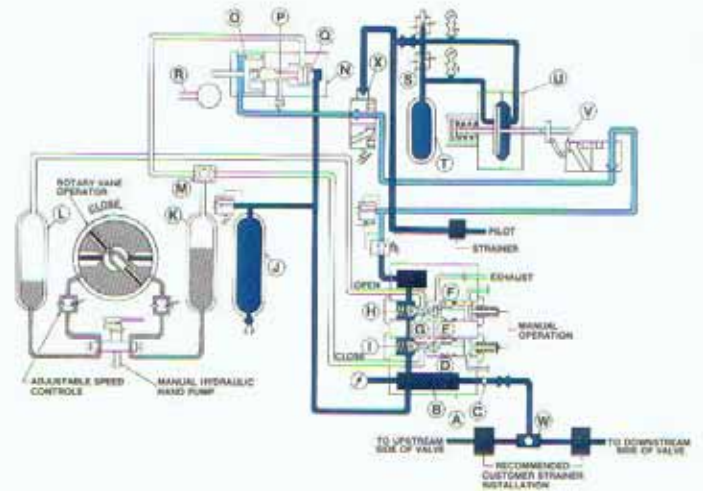

EMERSON™
Process Management