

# RV - Series

## Rotary Vane Valve Actuators

### Actuator Specifications & Dimensional Data

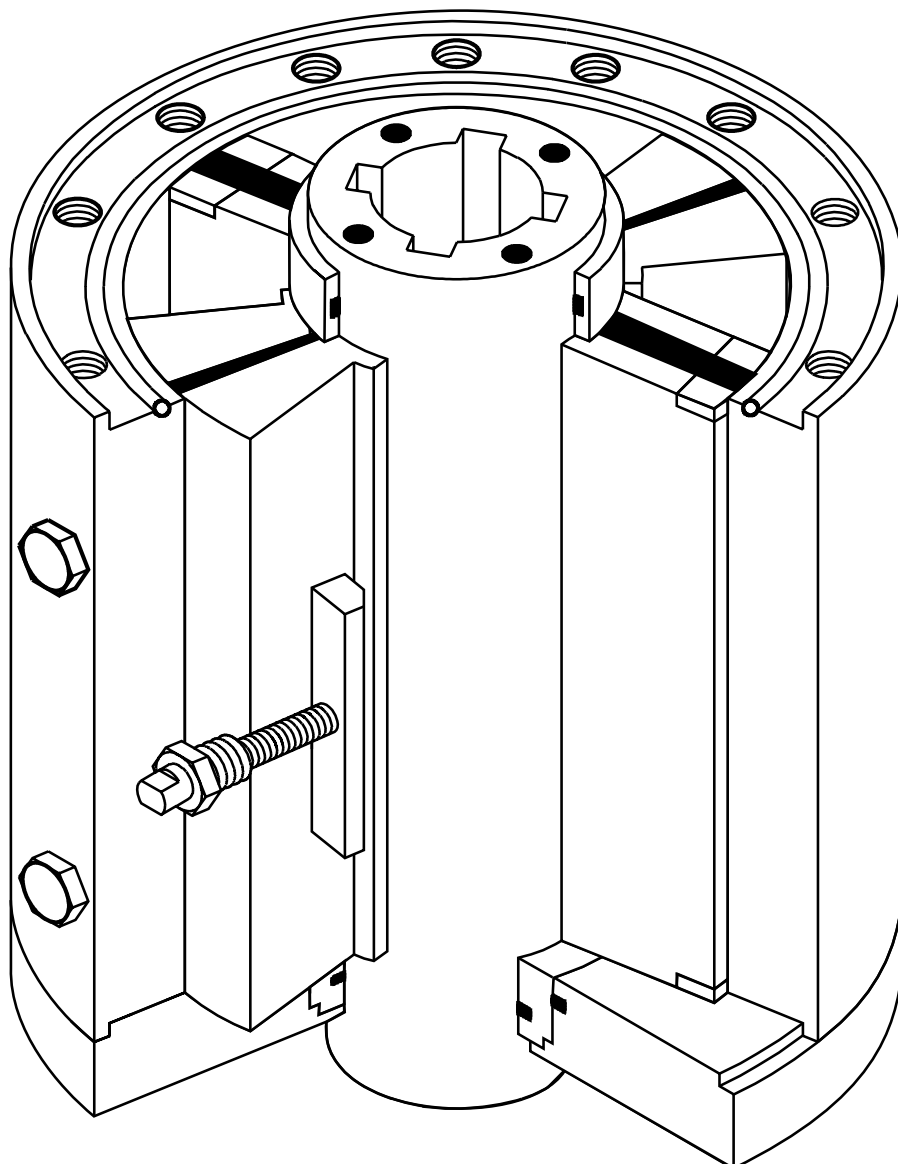

#### U. S. CUSTOMARY UNITS

Dimensions : Inches (in)

Torque: Inch Pounds (in-lbs)

Pressure: Pounds Per Square Inch (psi)

Weight: Pounds (lbs)

Volume: Cubic Inches (in<sup>3</sup>)

# Actuator Specifications

**NOTE:** Bolt circle, rotor bore, keyway quantity and size of mounting holes for RV-Series actuators will be custom fitted to specific valve.  
All dimensional data is subject to change. ALL DIMENSIONS SHOWN IN INCHES.

**BOTTOM VIEW**

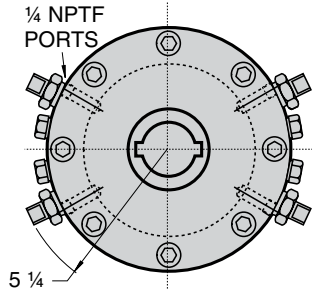

**SIDE VIEW**

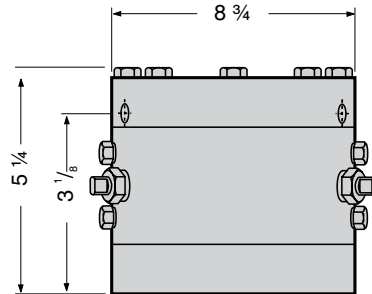

## 6 1/2 x 2 ROTARY VANE ACTUATOR

- Torque expression: 11.5 in. lb./psi
- Maximum working pressure 1440 psi
- Maximum test pressure 3000 psi
- Note: Consult factory if higher pressure rating required.
- Minimum working pressure 100 psi
- Maximum acceptable valve stem 2-5/8 in. diameter
- Maximum wrench square 2 in. across flats
- Weight of actuator including hydraulic fluid 39 lbs.
- Actual fluid displacement per 90° stroke equals 21 cu. in.
- On all units equipped with gas hydraulic tanks:  
Gas consumption per 90° stroke equals 2.1 standard cu. ft. @ 1000 psi
- Number of strokes of standard 4 cu. in. hand pump per 90° stroke equals 6.

**BOTTOM VIEW**

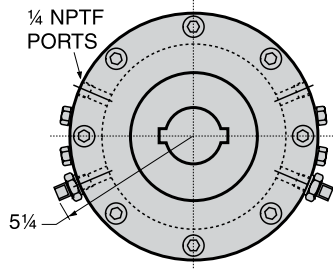

**SIDE VIEW**

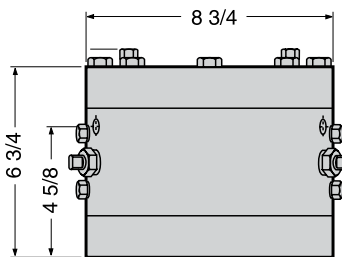

## 6 1/2 x 3 1/2 ROTARY VANE ACTUATOR

- Torque expression: 20.0 in. lb./psi
- Maximum working pressure 1440 psi
- Maximum test pressure 3000 psi
- Note: Consult factory if higher pressure rating required.
- Minimum working pressure 100 psi
- Maximum acceptable valve stem 2-5/8 in. diameter
- Maximum wrench square 2 in. across flats
- Weight of actuator including hydraulic fluid 94 lbs.
- Actual fluid displacement per 90° stroke equals 36 cu. in.
- On all units equipped with gas hydraulic tanks:  
Gas consumption per 90° stroke equals 6.53 standard cu. ft. @ 1000 psi
- Number of strokes of standard 4 cu. in. hand pump per 90° stroke equals 9.

**BOTTOM VIEW**

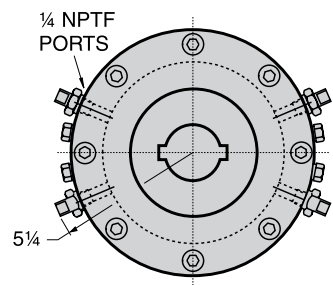

**SIDE VIEW**

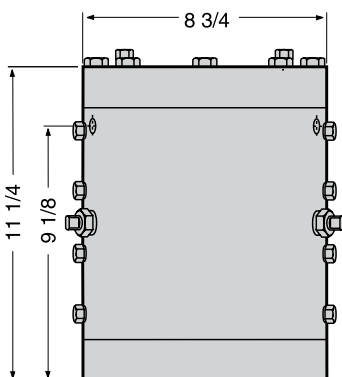

## 6 1/2 x 8 ROTARY VANE ACTUATOR

- Torque expression: 47.3 in. lb./psi
- Maximum working pressure 1440 psi
- Maximum test pressure 3000 psi
- Note: Consult factory if higher pressure rating required.
- Minimum working pressure 100 psi
- Maximum acceptable valve stem 2-5/8 in. diameter
- Maximum wrench square 2 in. across flats
- Weight of actuator including hydraulic fluid 140 lbs.
- Actual fluid displacement per 90° stroke equals 82 cu. in.
- On all units equipped with gas hydraulic tanks:  
Gas consumption per 90° stroke equals 8.37 standard cu. ft. @ 1000 psi
- Number of strokes of standard 4 cu. in. hand pump per 90° stroke equals 21.

**BOTTOM VIEW**

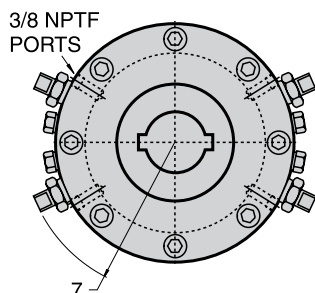

**SIDE VIEW**

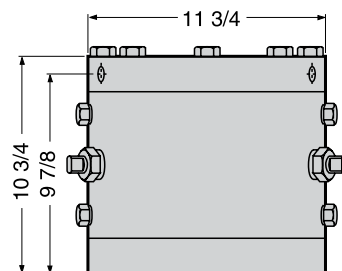

## 9 x 7 ROTARY VANE ACTUATOR

- Torque expression: 72.0 in. lb./psi
- Maximum working pressure 1440 psi
- Maximum test pressure 3000 psi
- Note: Consult factory if higher pressure rating required.
- Minimum working pressure 100 psi
- Maximum acceptable valve stem 3-3/4 in. diameter
- Maximum wrench square 2-1/2 in. across flats
- Weight of actuator including hydraulic fluid 230 lbs.
- Actual fluid displacement per 90° stroke equals 125 cu. in.
- On all units equipped with gas hydraulic tanks:  
Gas consumption per 90° stroke equals 12.5 standard cu. ft. @ 1000 psi
- Number of strokes of standard 4 cu. in. hand pump per 90° stroke equals 32.

# Actuator Specifications

**NOTE:** Bolt circle, rotor bore, keyway quantity and size of mounting holes for RV-Series actuators will be custom fitted to specific valve.  
All dimensional data is subject to change. ALL DIMENSIONS SHOWN IN INCHES.

**BOTTOM VIEW**

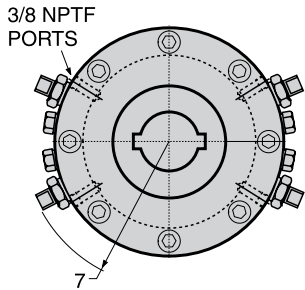

**SIDE VIEW**

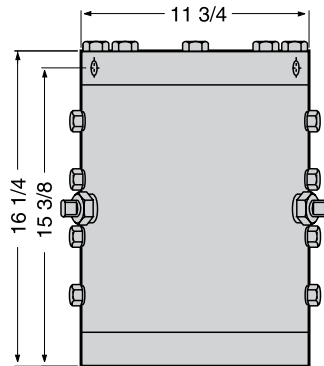

## 9 x 12 ROTARY VANE ACTUATOR

- Torque expression: 128.5 in. lb./psi
- Maximum working pressure 1440 psi
- Maximum test pressure 3000 psi
- Note: Consult factory if higher pressure rating required.
- Minimum working pressure 100 psi
- Maximum acceptable valve stem 3-3/4 in. diameter
- Maximum wrench square 2-1/2 in. across flats
- Weight of actuator including hydraulic fluid 347 lbs.
- Actual fluid displacement per 90° stroke equals 225 cu. in.
- On all units equipped with gas hydraulic tanks:  
Gas consumption per 90° stroke equals 22.5 standard cu. ft. @ 1000 psi
- Number of strokes of standard 4 cu. in. hand pump per 90° stroke equals 57.

**BOTTOM VIEW**

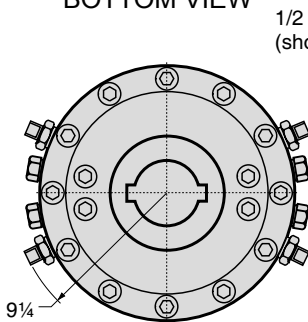

**SIDE VIEW**

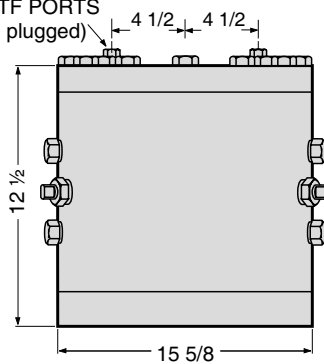

## 12 1/2 x 8 ROTARY VANE ACTUATOR

- Torque expression: 186.77 in. lb./psi
- Maximum working pressure 1440 psi
- Maximum test pressure 2880 psi
- Note: Consult factory if higher pressure rating required.
- Minimum working pressure 100 psi
- Maximum acceptable valve stem 4-1/2 in. diameter
- Maximum wrench square 3-1/4 in. across flats
- Weight of actuator including hydraulic fluid 500 lbs.
- Actual fluid displacement per 90° stroke equals 327 cu. in.
- On all units equipped with gas hydraulic tanks:  
Gas consumption per 90° stroke equals 32.6 standard cu. ft. @ 1000 psi
- Number of strokes of standard 4 cu. in. hand pump per 90° stroke equals 82.

**BOTTOM VIEW**

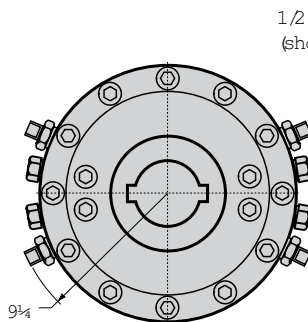

**SIDE VIEW**

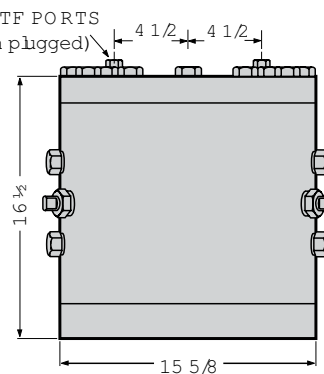

## 12 1/2 x 12 ROTARY VANE ACTUATOR

- Torque expression: 288.0 in. lb./psi
- Maximum working pressure 1440 psi
- Maximum test pressure 2880 psi
- Note: Consult factory if higher pressure rating required.
- Minimum working pressure 100 psi
- Maximum acceptable valve stem 4-1/2 in. diameter
- Maximum wrench square 3-1/4 in. across flats
- Weight of actuator including hydraulic fluid 660 lbs.
- Actual fluid displacement per 90° stroke equals 490 cu. in.
- On all units equipped with gas hydraulic tanks:  
Gas consumption per 90° stroke equals 48.9 standard cu. ft. @ 1000 psi
- Number of strokes of standard 4 cu. in. hand pump per 90° stroke equals 123.

**BOTTOM VIEW**

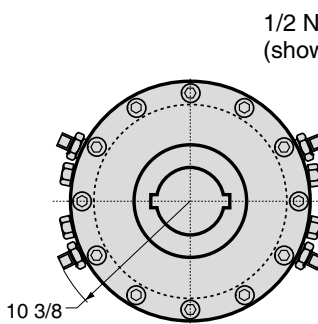

**SIDE VIEW**

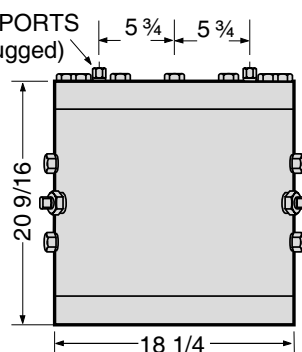

## 14 1/2 x 16 ROTARY VANE ACTUATOR

- Torque expression: 522.0 in. lb. @/psi
- Maximum working pressure 1440 psi
- Maximum test pressure 2440 psi
- Note: Consult factory if higher pressure rating required.
- Minimum working pressure 100 psi
- Maximum acceptable valve stem 5-1/2 in. diameter
- Weight of actuator including hydraulic fluid 1064 lbs.
- Actual fluid displacement per 90° stroke equals 913 cu. in.
- On all units equipped with gas hydraulic tanks:  
Gas consumption per 90° stroke equals 91.2 standard cu. ft. @ 1000 psi
- Number of strokes of standard 12 cu. in. hand pump per 90° stroke equals 76.

# Actuator Specifications

**NOTE:** Bolt circle, rotor bore, keyway quantity and size of mounting holes for RV-Series actuators will be custom fitted to specific valve.  
All dimensional data is subject to change. ALL DIMENSIONS SHOWN IN INCHES.

BOTTOM VIEW

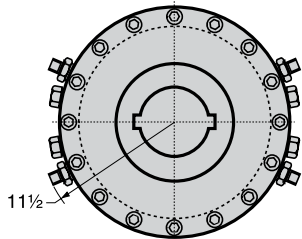

SIDE VIEW

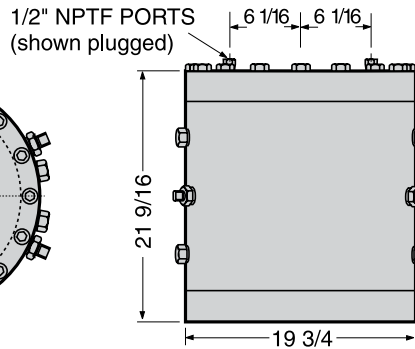

## 16 1/2 x 16 ROTARY VANE ACTUATOR

- Torque expression: 688.5 in. lb./psi
  - Maximum working pressure 1440 psi
  - Maximum test pressure 2160 psi
- Note: Consult factory if higher pressure rating required.
- Minimum working pressure 100 psi
  - Maximum acceptable valve stem 6 in. diameter
  - Weight of actuator including hydraulic fluid 1325 lbs.
  - Actual fluid displacement per 90° stroke equals 1280 cu. in.
  - On all units equipped with gas hydraulic tanks:  
Gas consumption per 90° stroke equals 127.8 standard cu. ft. @ 1000 psi
  - Number of strokes of standard 12 cu. in. hand pump per 90° stroke equals 107.

BOTTOM VIEW

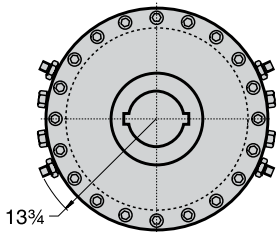

SIDE VIEW

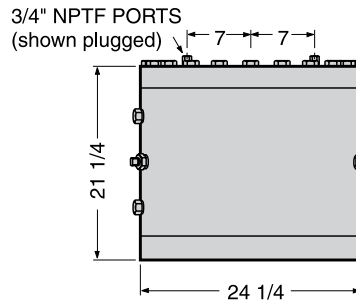

## 20 x 16 ROTARY VANE ACTUATOR

- Torque expression: 1,148.4 in. lb./psi
  - Maximum working pressure 1440 psi
  - Maximum test pressure 2250 psi
- Note: Consult factory if higher pressure rating required.
- Minimum working pressure 100 psi
  - Maximum acceptable valve stem 6 in. diameter
  - Weight of actuator including hydraulic fluid 1880 lbs.
  - Actual fluid displacement per 90° stroke equals 2013 cu. in.
  - On all units equipped with gas hydraulic tanks:  
Gas consumption per 90° stroke equals 201 standard cu. ft. @ 1000 psi
  - Number of strokes of standard 12 cu. in. hand pump per 90° stroke equals 168.

BOTTOM VIEW

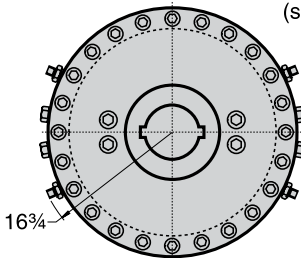

SIDE VIEW

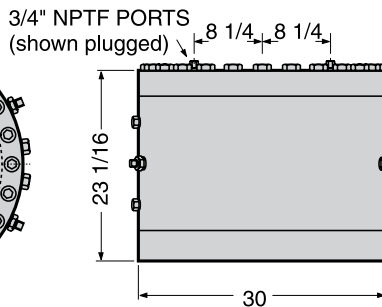

## 25 x 16 ROTARY VANE ACTUATOR

- Torque expression: 1,853.1 in. lb./psi
  - Maximum working pressure 1440 psi
  - Maximum test pressure 2160 psi
- Note: Consult factory if higher pressure rating required.
- Minimum working pressure 100 psi
  - Maximum acceptable valve stem 6-1/2 in. diameter
  - Weight of actuator including hydraulic fluid 2920 lbs.
  - Actual fluid displacement per 90° stroke equals 3232 cu. in.
  - On all units equipped with gas hydraulic tanks:  
Gas consumption per 90° stroke equals 322.8 standard cu. ft. @ 1000 psi
  - Number of strokes of standard 12 cu. in. hand pump per 90° stroke equals 270.

BOTTOM VIEW

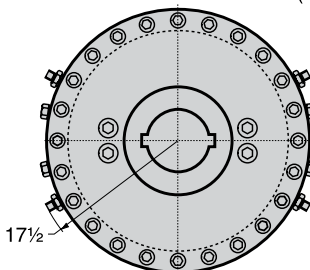

SIDE VIEW

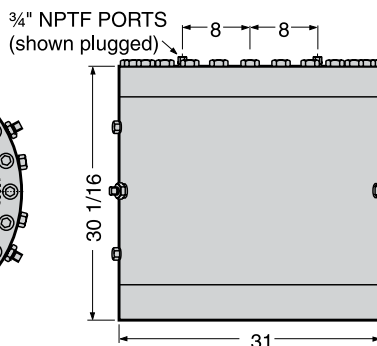

## 26 x 22 ROTARY VANE ACTUATOR

- Torque expression: 2,691.5 in. lb./psi
  - Maximum working pressure 1440 psi
  - Maximum test pressure 2160 psi
- Note: Consult factory if higher pressure rating required.
- Minimum working pressure 100 psi
  - Maximum acceptable valve stem 7-3/8 in. diameter
  - Weight of actuator including hydraulic fluid 4050 lbs.
  - Actual fluid displacement per 90° stroke equals 4697 cu. in.
  - On all units equipped with gas hydraulic tanks:  
Gas consumption per 90° stroke equals 469.1 standard cu. ft. @ 1000 psi
  - Number of strokes of standard 12 cu. in. hand pump per 90° stroke equals 392.

# Actuator Specifications

**NOTE:** Bolt circle, rotor bore, keyway quantity and size of mounting holes for RV-Series actuators will be custom fitted to specific valve.  
All dimensional data is subject to change. ALL DIMENSIONS SHOWN IN INCHES.

BOTTOM VIEW

SIDE VIEW

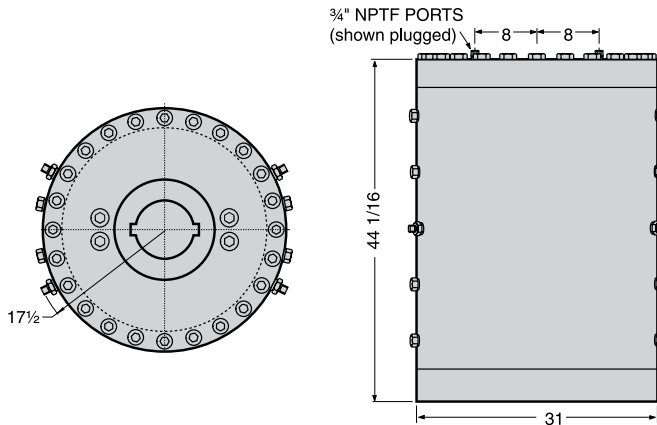

## 26 x 36 ROTARY VANE ACTUATOR

- Torque expression: 4,338.0 in. lb./psi
- Maximum working pressure 1000 psi
- Maximum test pressure 2000 psi
- Note: Consult factory if higher pressure rating required.
- Minimum working pressure 100 psi
- Maximum acceptable valve stem 7-3/8 in. diameter
- Weight of actuator including hydraulic fluid 7687 lbs.
- Actual fluid displacement per 90° stroke equals 7686 cu. in.
- On all units equipped with gas hydraulic tanks:
  - Gas consumption per 90° stroke equals 767.6 standard cu. ft. @ 1000 psi
  - Number of strokes of standard 12 cu. in. hand pump per 90° stroke equals 641.

BOTTOM VIEW

SIDE VIEW

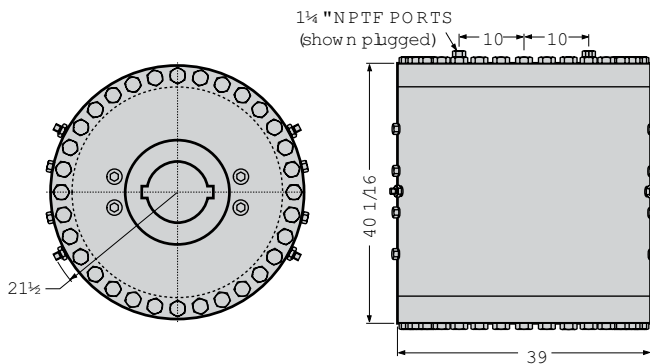

## 33 x 32 ROTARY VANE ACTUATOR

- Torque expression: 5,868.0 in. lb./psi
- Maximum working pressure 1000 psi
- Maximum test pressure 1500 psi
- Note: Consult factory if higher pressure rating required.
- Minimum working pressure 100 psi
- Maximum acceptable valve stem 9-1/2 in. diameter
- Weight of actuator including hydraulic fluid 8,900 lbs.
- Actual fluid displacement per 90° stroke equals 10,857 cu. in.
- On all units equipped with gas hydraulic tanks:
  - Gas consumption per 90° stroke equals 1,084.2 standard cu. ft. @ 1000 psi
  - Number of strokes of standard 12 cu. in. hand pump per 90° stroke equals 905.

# Actuator Specifications

## SPEED OF OPERATION IN SECONDS PER 90° ROTATION\*

ACTUATOR SIZE	OPERATING PRESSURE psiG													
	100	200	300	400	500	600	700	800	900	1000	1100	1200	1300	1400
6 ½ x 2	8	5	4	4	3	3	3	2	2	2	2	2	1	1
6 ½ x 3 ½	9	6	5	5	4	3	3	3	2	2	2	2	1	1
6 ½ x 8	10	7	6	6	5	4	4	4	3 ½	3 ½	3	3	2	1
9 x 7	14	11	9	8	8	7	5	5	5	5	3	3	2	2
9 x 12	15	13	11	10	9	9	8	7	6	6	5	4	4	3
12 ½ x 8	15	14	12	11	11	10	9	9	8	8	7	6	6	6
12 ½ x 12	20	18	18	16	15	13	10	10	10	10	9	9	9	9
14 ½ x 16	32	25	20	18	16	14	14	12	12	12	12	11	11	11
16 ½ x 16	40	30	28	23	20	19	17	16	15	15	15	15	15	14
20 x 16	40	35	30	25	24	22	20	20	20	19	19	19	19	18
25 x 16	76	53	43	37	33	30	25	25	24	24	24	24	22	22
26 x 22	80	60	50	40	35	30	25	25	25	25	25	25	25	25
26 x 36	90	80	70	50	45	40	38	35	35	35				
33 x 32	254	178	146	125	111	102	95	88	83	79				

\* Stroking speeds above are approximate as speed may be affected by fluid viscosity or the flow capacities of the individual control components. The listed speeds are based on actuators with gas hydraulic tanks, hand pump and the standard poppet type control block in the power supply circuit.

Adjustable speed control valves may be specified so that the stroking speed may be fine tuned to the field operating conditions. If faster speeds are required, please consult a factory representative.

# Actuator Specifications

## APPROXIMATE WEIGHTS FOR SHAFER ROTARY OPERATORS, HYDRAULIC TANKS AND POWER STORAGE TANKS

SIZE	OPERATOR WEIGHT lbs	HYDRAULIC TANKS WEIGHT lbs (Per Pair)	POWER STORAGE TANK (STANDARD) WEIGHT lbs
6 ½ x 2	39	35	20
6½ x 3½	100	35	20
6½ x 8	150	75	40
9 x 7	275	111	52
9 x 12	400	170	85
12 ½ x 8	500	265	125
12½ x 12	660	406	175
14½ x 16	1064	675	275
16½ x 16	1325	875	450
20 x 16	1880	1275	693
25 x 16	2920	2708	1181
26 x 22	4500	3348	1450
26 x 36	7687	5362	2315
33 x 32	8900	7448	3160

## APPROXIMATE WEIGHTS FOR SHAFER HAND PUMPS, 2-WAY ELECTRIC CONTROLS, AND LIMIT SWITCHES

PUMPS	CONTROL (TWO-WAY ELECTRIC)	LIMIT SWITCH
4 cu. in. = 20 lbs.	1/4 in. = 60 lbs.	LARGE = 25 lbs.
12 cu. in. = 44 lbs.	1/2 in. = 75 lbs.	-----

4 cu. in. Pump, 1/4 Poppet Block = 52 lbs. + Cover 28 lbs. = Total 80 lbs.

12 cu. in. Pump, 1/4 Poppet Block= 102 lbs. + Cover 42 lbs. = Total 144 lbs.

Linebreak Small Plate with Lockout = 42 lbs. + Cover 22 lbs. = 64 lbs.

4 cu. in. Pump / D.H.V. = 50 lbs.

12 cu. in. Pump / D.H.V. = 110 lbs.

Limit Valve (ESD) with Plate 10 lbs.

1-08672 Terminal Box= 10 lbs.

1-09027 Terminal Box = 12 lbs.

1/4 Poppet Block, 4 cu. in. Pump & Linebreak with cover = 95 lbs.

# Dimensional Data

**NOTE:** All dimensional data is for reference only and subject to change. Depending on the application, specific actuator controls may or may not be located inside of the control box. Where specified, there may be additional pressure vessels or power storage tanks which are not shown.

## GAS / HYDRAULIC ROTARY VANE - HORIZONTAL STEM, VERTICAL LINE

SIZE	A	B	C	D	E	F	G	H	J	K	L	M
6 1/2 x 2	5 1/4	24 1/2	29	23 1/4	25 1/4	18 1/4	19 1/4	16 1/4	8 3/4	9 1/4	1/2	2 1/4
6 1/2 x 3 1/2	6 3/4	24 1/2	29	23 1/4	25 1/4	18 1/4	19 1/4	16 1/4	8 3/4	9 1/4	1/2	3 3/4
6 1/2 x 8	11 1/4	24 1/2	29	30	25 1/4	18 1/4	19 1/4	16 1/4	8 3/4	9 1/4	4 3/4	6 1/2
9 x 7	10 3/4	29 3/4	35 1/2	30 3/4	25 1/4	21 1/4	19 1/4	21 1/4	11 3/4	10 3/4	4 1/4	5 1/2
9 x 12	16 1/4	30 1/2	36 1/4	37 1/2	25 1/4	23 1/4	19 1/4	22	11 3/4	11 3/4	7 1/2	11
12 1/2 x 8	12 1/2	32 1/2	39 1/4	45 1/4	25 1/4	23 1/4	19 1/4	24	15 3/4	11 3/4	11 1/2	7 1/2
12 1/2 x 12	17	33 3/4	41 1/2	42	25 1/4	27 1/4	19 1/4	25 1/4	15 3/4	12 1/4	10	10 3/4
14 1/2 x 16	20 9/16	44 1/2	53 1/2	47	32 1/2	33 1/2	23	32	18 1/4	16 1/2	7	9 1/4
16 1/2 x 16	22 1/2	45 3/4	55 3/4	60 1/4	32 1/2	33 1/2	23	33 1/2	19 3/4	16 1/2	13 1/4	10 3/4
20 x 16	23 1/4	49 1/2	61 1/2	58	32 1/2	40	23	37	24 1/4	17 1/2	12 1/4	10 1/2
25 x 16	24 3/4	51 1/4	66 1/4	67 3/4	36 1/4	44	25 1/4	37 1/2	30	11 1/2	17 1/4	10 1/4
26 x 22	32 1/4	*	*	*	36 1/4	*	25 1/4	*	31	*	*	*
26 x 36	45 1/2	*	*	*	36 1/4	*	25 1/4	*	31	*	*	*
33 x 32	41 1/4	*	*	*	36 1/4	*	25 1/4	*	39	*	*	*

\* Indicates this particular size of actuator has not been used in this type of application.  
**All dimensions shown in inches.**

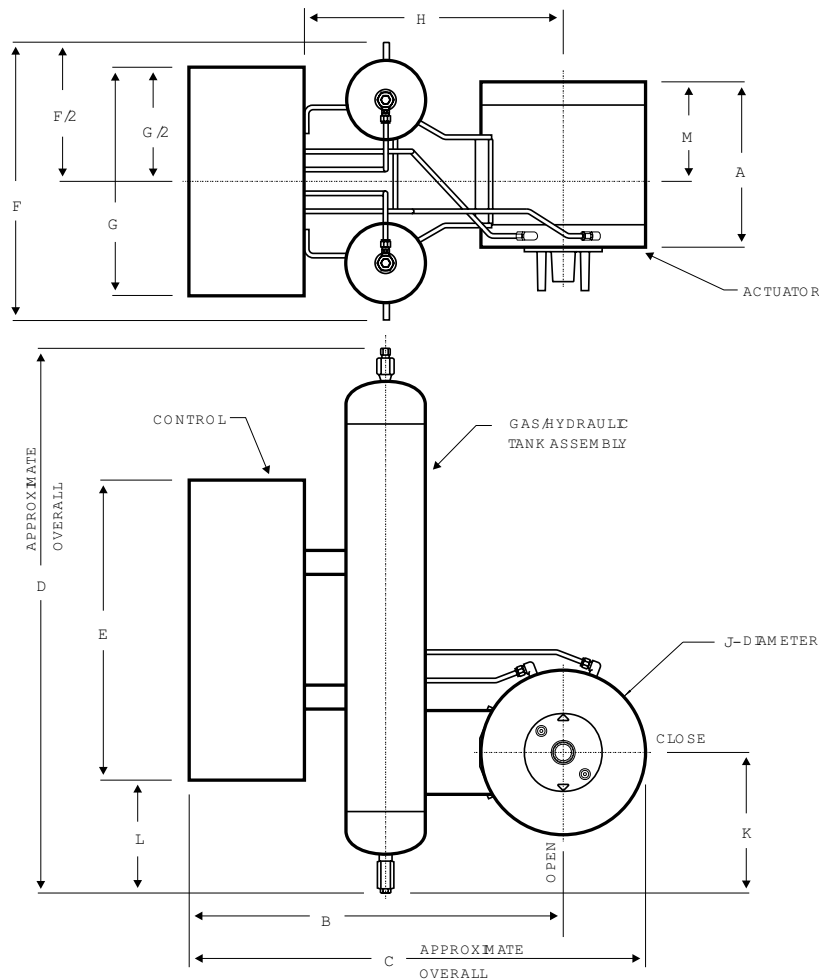

# Dimensional Data

**NOTE:** All dimensional data is for reference only and subject to change. Depending on the application, specific actuator controls may or may not be located inside of the control box. Where specified, there may be additional pressure vessels or power storage tanks which are not shown.

## GAS / HYDRAULIC ROTARY VANE - VERTICAL STEM, HORIZONTAL LINE

SIZE	A	B	C	D	E	F	G	H	J	K	M
6 1/2 x 2	5 1/4	24 1/4	28 1/2	23 1/4	25 1/4	18 1/4	19 1/4	15 3/4	8 3/4	1/2	5 1/4
6 1/2 x 3 1/2	6 3/4	24 1/4	28 1/2	23 1/4	25 1/4	18 1/4	19 1/4	15 3/4	8 3/4	1/2	5
6 1/2 x 8	11 1/4	24 1/4	28 1/2	30	25 1/4	18 1/4	19 1/4	15 3/4	8 3/4	4 3/4	3 1/4
9 x 7	10 3/4	27 1/2	33 1/2	30 3/4	25 1/4	21 1/4	19 1/4	19 1/4	11 3/4	4 1/4	5
9 x 12	16 1/4	28 1/2	34 1/4	37 1/2	25 1/4	23 1/4	19 1/4	20	11 3/4	7 1/2	3 1/2
12 1/2 x 8	12 1/2	32	39 3/4	45 1/4	25 1/4	23 1/4	19 1/4	23 1/2	15 3/4	9	2 1/2
12 1/2 x 12	17	32	39 3/4	42	25 1/4	27 1/4	19 1/4	23 1/2	15 3/4	10	3/4
14 1/2 x 16	20 9/16	38 3/4	47 3/4	47	32 1/2	33 1/2	23	26 1/4	18 1/4	7	5 1/4
16 1/2 x 16	22 1/2	40	50	60 1/4	32 1/2	33 1/2	23	27 3/4	19 3/4	13 1/4	1 1/4
20 x 16	23 1/4	44 1/4	56 1/4	58	32 1/2	40	23	31 3/4	24 1/4	12 1/4	6 1/2
25 x 16	24 1/2	51	66	67 3/4	36 1/2	44	25 1/4	36 1/2	30	13 1/2	9 1/4
26 x 22	32	37	68	84 1/4	36 1/2	48	25 1/4	38	31	21 3/4	6 3/4
26 x 36	45 1/4	58	73 1/2	69 1/2	36 1/2	57	25 1/4	43 1/2	31	13 1/4	8 1/2
33 x 32	41 1/4	62 1/4	81 3/4	97 1/2	36 3/4	57	25 1/4	47 3/4	39	28 1/4	10 3/4

\* Indicates this particular size of actuator has not been used in this type of application.

**All dimensions shown in inches.**

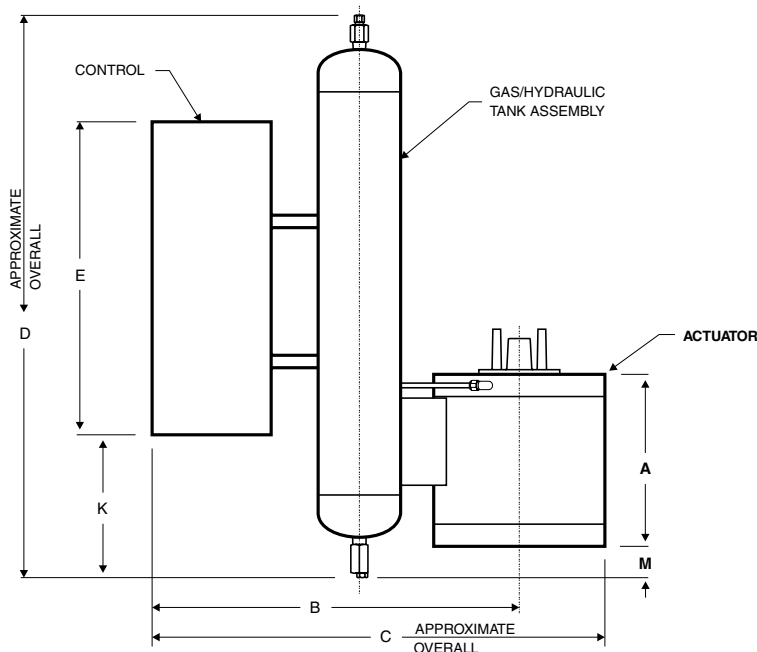
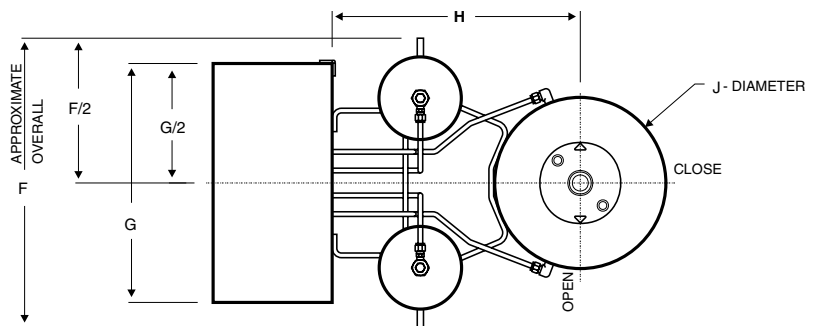

# Dimensional Data

**NOTE:** All dimensional data is for reference only and subject to change. Depending on the application, specific actuator controls may or may not be located inside of the control box. Where specified, there may be additional pressure vessels or power storage tanks which are not shown.

## CENTRAL HYDRAULIC SYSTEM - HORIZONTAL STEM, VERTICAL LINE

SIZE	A	B	C	D	E	F	G	H	J	K	L	M
6 1/2 x 2	5 1/4	23 1/2	27	30 3/4	22 3/4	22	19 1/4	17	8 3/4	12 1/2	4 1/2	2 1/4
6 1/2 x 3 1/2	6 3/4	24 3/4	29	30 3/4	22 3/4	22	19 1/4	17	8 3/4	12 1/2	4 1/2	3 3/4
6 1/2 x 8	11 1/4	24 3/4	29	30 3/4	22 3/4	22	19 1/4	17	8 3/4	12 1/2	4 1/2	6 1/2
9 x 7	10 3/4	26 1/4	32	31 1/2	22 3/4	22	19 1/4	18 1/2	11 3/4	12 1/2	5	5 1/4
9 x 12	16 1/4	26 1/4	32	31 1/2	22 3/4	22 1/2	19 1/4	18 1/2	11 3/4	12 1/2	5	10 3/4
12 1/2 x 8	12 1/2	28	36	32 1/2	22 3/4	23 1/4	19 1/4	20 1/2	15 3/4	12 1/2	5	8 3/4
12 1/2 x 12	17	28	36	33 1/2	22 3/4	23 1/4	19 1/4	20 1/2	15 3/4	12 1/2	5	10 3/4
14 1/2 x 16	20 9/16	34 1/4	43 1/4	34 3/4	32 1/2	26 1/2	28 1/4	23 1/4	18 1/4	12 1/2	9	9 1/4
16 1/2 x 16	22 1/2	35	45	35 1/2	32 1/2	26 1/2	28 1/4	24	19 3/4	12 1/2	9	10 3/4
20 x 16	23 1/4	37 1/2	49 3/4	37 3/4	32 1/2	26 1/2	28 1/4	26 1/2	24 1/4	12 1/2	9	10 1/2
25 x 16	24 1/2	36 3/4	51 3/4	46	36 1/2	25	25 1/4	28 3/4	30	12 1/2	5 1/2	12 1/4
26 x 22	32	*	*	*	36 1/2	*	25 1/4	*	31	*	*	*
26 x 36	45 1/4	*	*	*	36 1/2	*	25 1/4	*	31	*	*	*
33 x 32	41 1/4	*	*	*	36 1/2	*	25 1/4	*	39	*	*	*

\* Indicates this particular size of actuator has not been used in this type of application.  
All dimensions shown in inches.

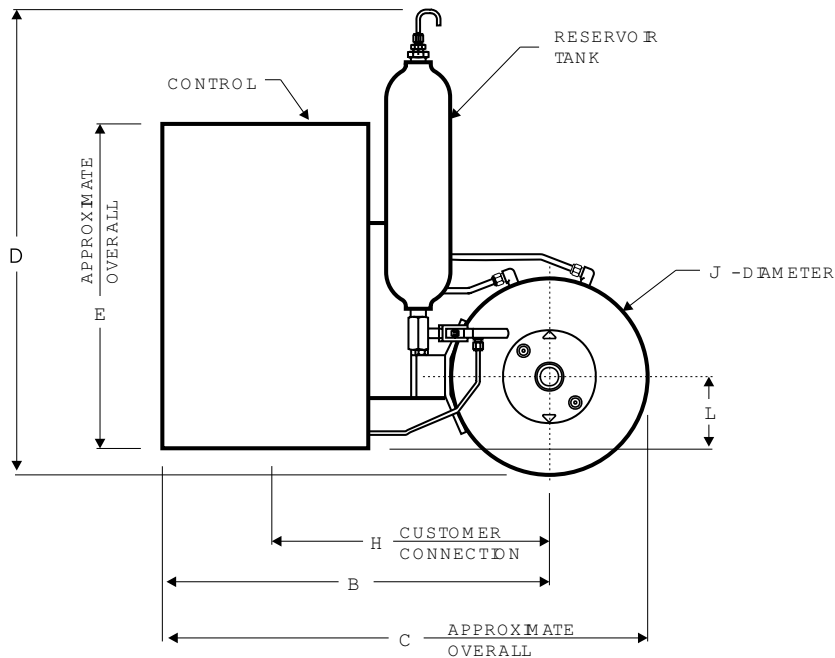
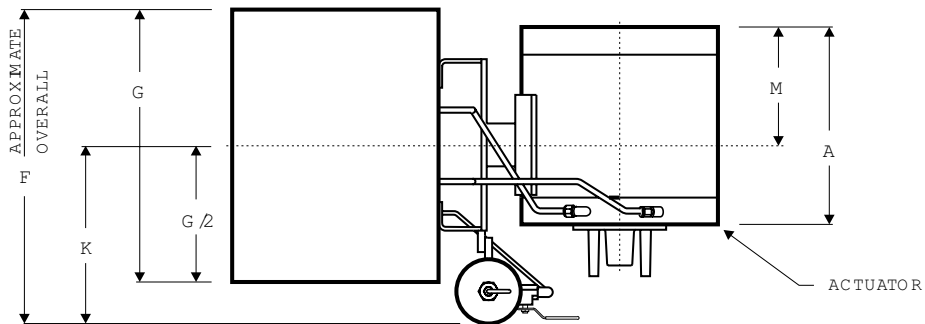

# Dimensional Data

**NOTE:** All dimensional data is for reference only and subject to change. Depending on the application, specific actuator controls may or may not be located inside of the control box. Where specified, there may be additional pressure vessels or power storage tanks which are not shown.

## CENTRAL HYDRAULIC SYSTEM - VERTICAL STEM, HORIZONTAL LINE

SIZE	A	B	C	D	E	F	G	H	J	K	L
6 1/2 x 2	5 1/4	24 3/4	29	31 1/4	22 3/4	22	19 1/4	17	8 3/4	12 1/2	1/2
6 1/2 x 3 1/2	6 3/4	24 3/4	29	31 3/4	22 3/4	22	19 1/4	17	8 3/4	12 1/2	1
6 1/2 x 8	11 1/4	24 3/4	29	34 1/2	22 3/4	22	19 1/4	17	8 3/4	12 1/2	3 3/4
9 x 7	10 3/4	26	32	33	22 3/4	22	19 1/4	18 1/2	11 3/4	12 1/2	2 1/2
9 x 12	16 1/4	26	32	38 1/2	22 3/4	22	19 1/4	18 1/2	11 3/4	12 1/2	8
12 1/2 x 8	12 1/2	27 1/4	34	34 1/2	22 3/4	22	19 1/4	19 1/2	15 3/4	12 1/2	1 1/2
12 1/2 x 12	17	28 1/4	36	38 1/2	22 3/4	22	19 1/4	20 3/4	15 3/4	12 1/2	7 3/4
14 1/2 x 16	20 9/16	34 1/4	43 1/4	40 1/2	32 1/2	26 1/2	28 1/4	23 1/4	18 1/4	12 1/2	4
16 1/2 x 16	22 1/2	35	45	41	32 1/2	26 1/2	28 1/4	24	19 3/4	12 1/2	6 1/2
20 x 16	23 1/4	37 1/2	49 3/4	40 3/4	32 1/2	26 1/2	28 1/4	26 1/2	24 1/4	12 1/2	6
25 x 16	24 1/2	36 3/4	51 3/4	50 3/4	36 1/2	25	25 1/4	28 1/2	30	12 1/2	14 1/4
26 x 22	32	37 1/4	52 3/4	53 1/4	36 1/2	25	25 1/4	28 3/4	31	12 1/2	16 3/4
26 x 36	45 1/4	*	*	*	36 1/2	*	25 1/4	*	31	*	*
33 x 32	41 1/4	*	*	*	36 1/2	*	25 1/4	*	39	*	*

\* Indicates this particular size of actuator has not been used in this type of application.  
**All dimensions shown in inches.**

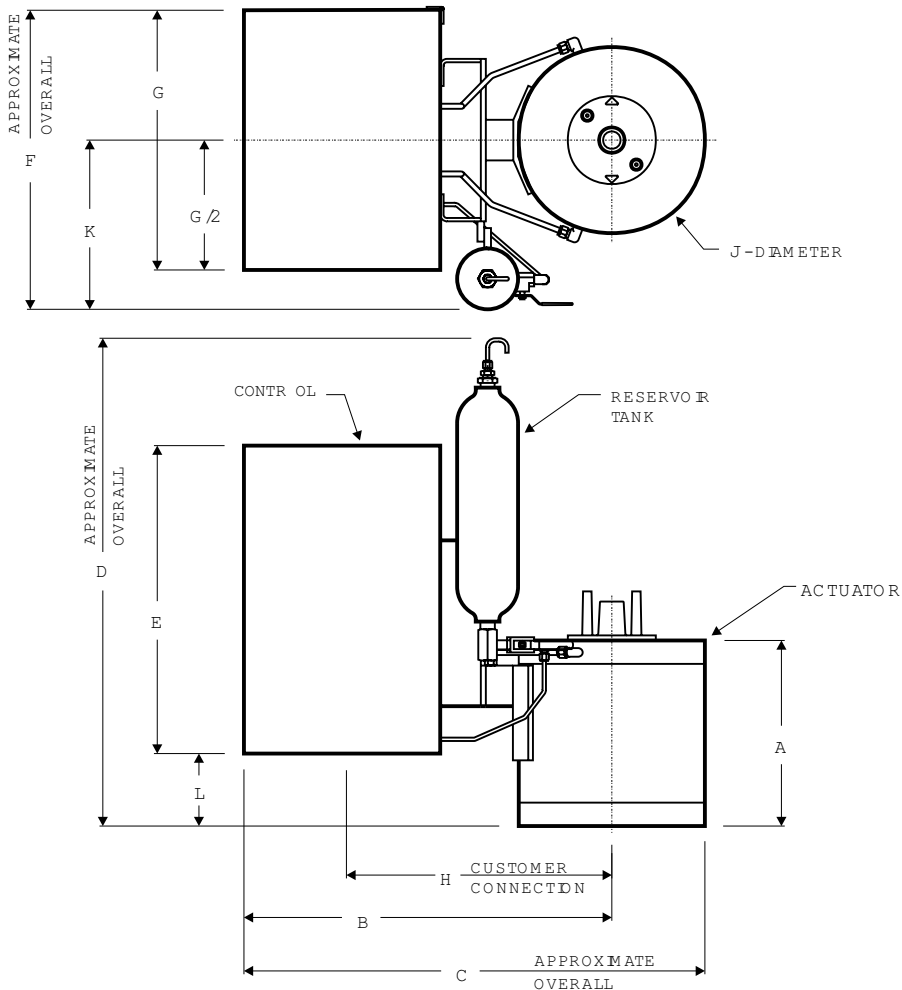

2500 Park Ave. West, Mansfield, OH 44906  
Phone (419) 529-4311 • FAX (419) 529-3688

RV-ASDD-D-3-06-09