

POPPET BLOCK CONTROL MAINTENANCE AND SERVICE MANUAL

USASI SCHEMATIC

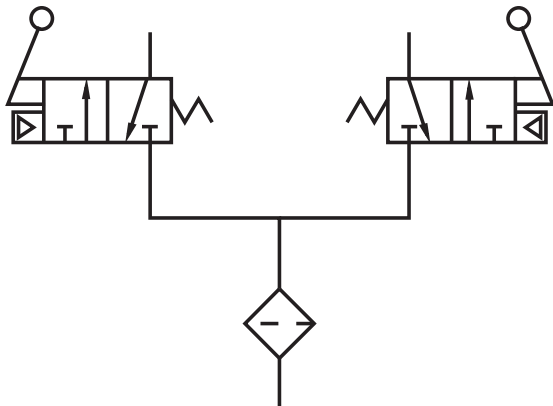

Normally closed, double three-way poppet valve, with open exhaust, manual and pilot actuated.

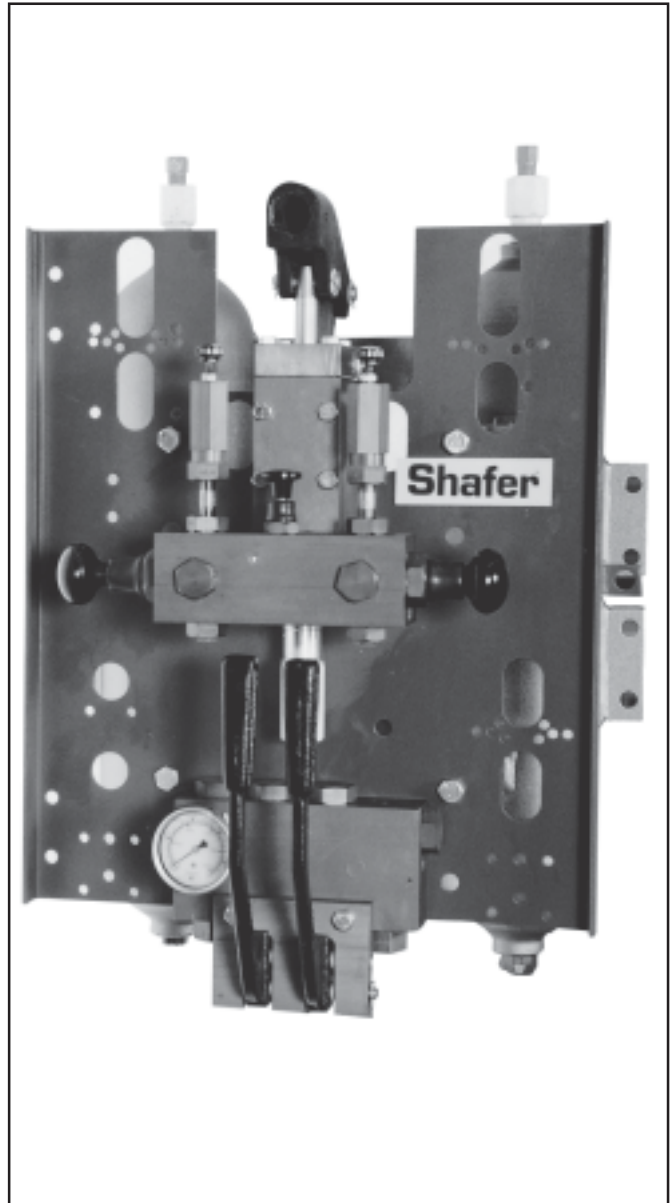
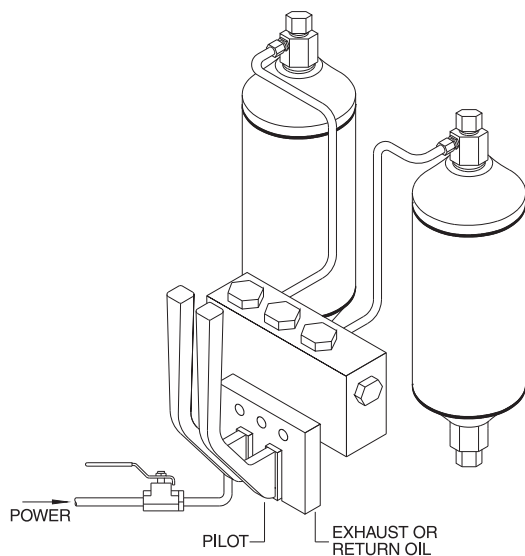

POPPET BLOCK GAS OR OIL FLOW

INTRODUCTION

The poppet block is the heart of most Shafer control systems. A double three-way, manual and pilot actuated, control valve is designed to provide selective directional operation of Shafer actuators. The poppet block control may direct power gas to a set of gas/hydraulic tanks (generating hydraulic pressure for powering valve actuators), or it may direct central hydraulic system pressure directly into a valve actuator. It is engineered to provide reliable and durable operation and toleration of contaminants in the power source.

BASIC CONSTRUCTION

The poppet block control consists of a double three-way ported valve body containing two sets of inexpensive, easily replaced nylon poppets to provide tight sealing, poppet springs, push pins, power and pilot filters, a manual lever assembly and pilot pistons for remote operation.

NOTE: For low pressure applications, 350 psi or less, the power poppets item (2) in Figure 1 are steel backed Neoprene poppets. The exhaust poppets item (3) in Figure 1 are nylon.

OPERATION

FIGURE 1 - NEUTRAL POSITION

Spring compression (1) and power gas force the power poppets (2) on their respective seats and simultaneously hold exhaust poppets (3) in the open position via interconnecting poppet pins. Tank porting is open to exhaust. The exhaust port is equipped with a check valve (4) to prevent atmosphere from entering the poppet block assembly.

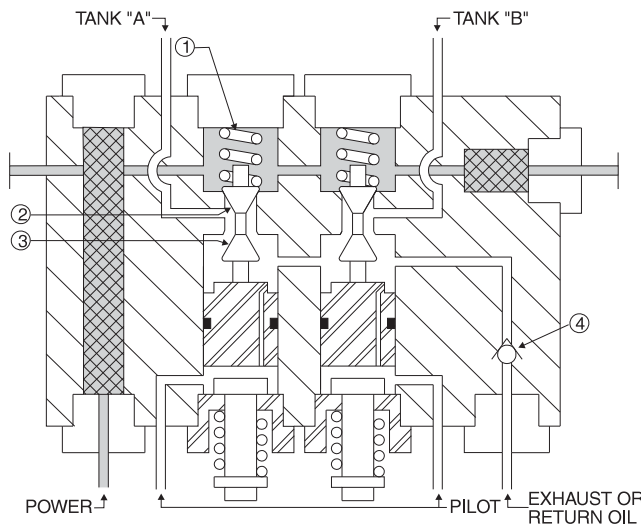

FIGURE 1

FIGURE 2A - PILOT ACTIVATION

Pilot pressure to the pilot piston (5) illustrates force applied to the piston seating the exhaust poppet and simultaneously unseating the power poppet. Power gas is directed through tank port "B".

NOTE: Pilot pressure to the opposite pilot piston shown in Figure 2A will activate the opposite set of poppets and direct power gas to tank port "A".

NOTE: Pilot pistons are equipped with an orifice in order to vent the pilot pressure and allow the control to neutralize after stroking an actuator.

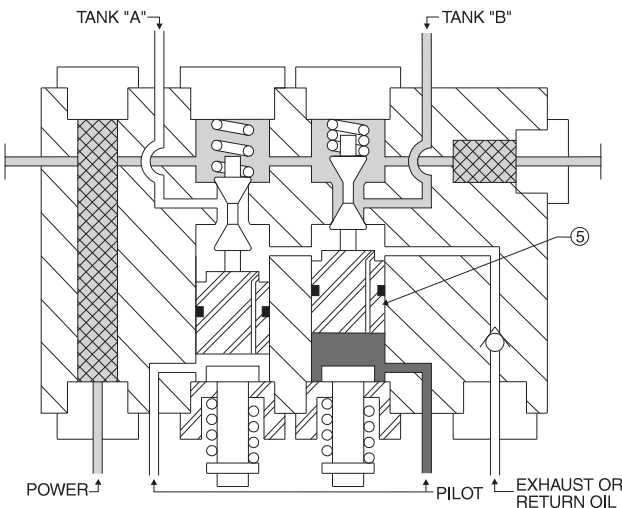

FIGURE 2A

POPPET BLOCK GAS OR OIL FLOW

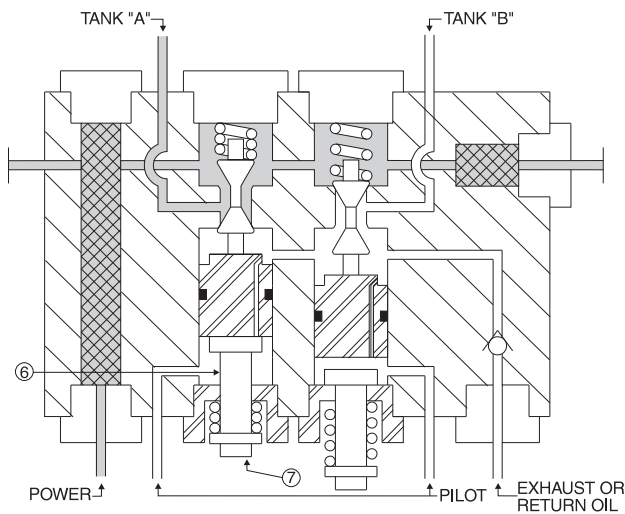
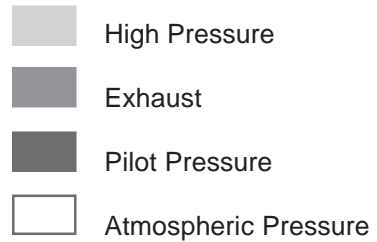

FIGURE 2B

FIGURE 2B - MANUAL ACTIVATION

Movement of the lever (7) illustrates force applied by the stem (6), seating the exhaust poppet and simultaneously unseating the power poppet. Power gas is directed through tank port "A".

NOTE: Movement of the opposite lever shown in Figure 2B will activate the opposite set of poppets and direct power gas to tank port "B".

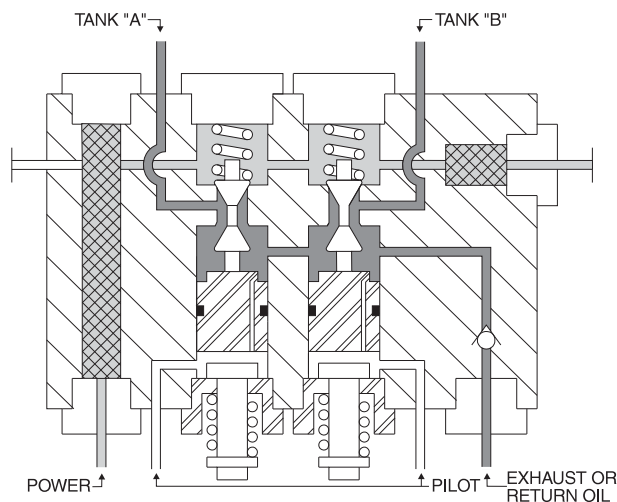

FIGURE 3

FIGURE 3 - NEUTRALIZATION

Release of the lever will allow the compressed poppet spring and power gas to reseat the power poppet and simultaneously unseat the exhaust poppet. Power gas pressure remaining in the gas/hydraulic tank is now vented through port "B" to the exhaust, thus neutralizing tank and actuator pressures.

BASIC CHECK-OUT PROCEDURES

The following two checks illustrate proper working functions of the Shafer Poppet Block. Failure of any of these procedures may result in operating problems with the valve actuator. This description is for gas service, but the unit can also be used in hydraulic service.

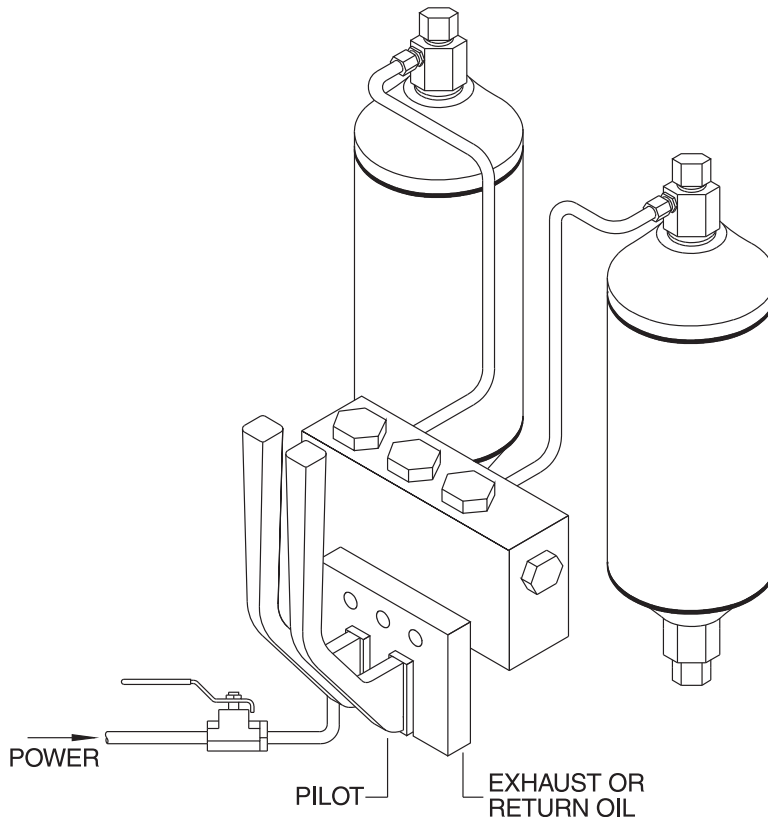

CHECK NO. 1

There should be zero leakage throughout the control system.

In the neutralized position there should be zero power gas leakage from the exhaust port.

Power gas leakage is usually attributed to debris lodged between the power poppet and seat.

CHECK NO. 2

Pull the manual lever to full travel and stroke the actuator partially open or closed.

NOTE: The manual lever for open and close is indicated on the attached tag.

After stroking the actuator partially open or closed, release the manual lever thus exhausting the gas/hydraulic tank.

After the gas/hydraulic tank is completely exhausted, check the exhaust port for any gas leakage.

NOTE: The exhaust port should be free of any restrictions or piping size reductions less than 1/2 NPTF unless factory supplied.

BILL OF MATERIAL

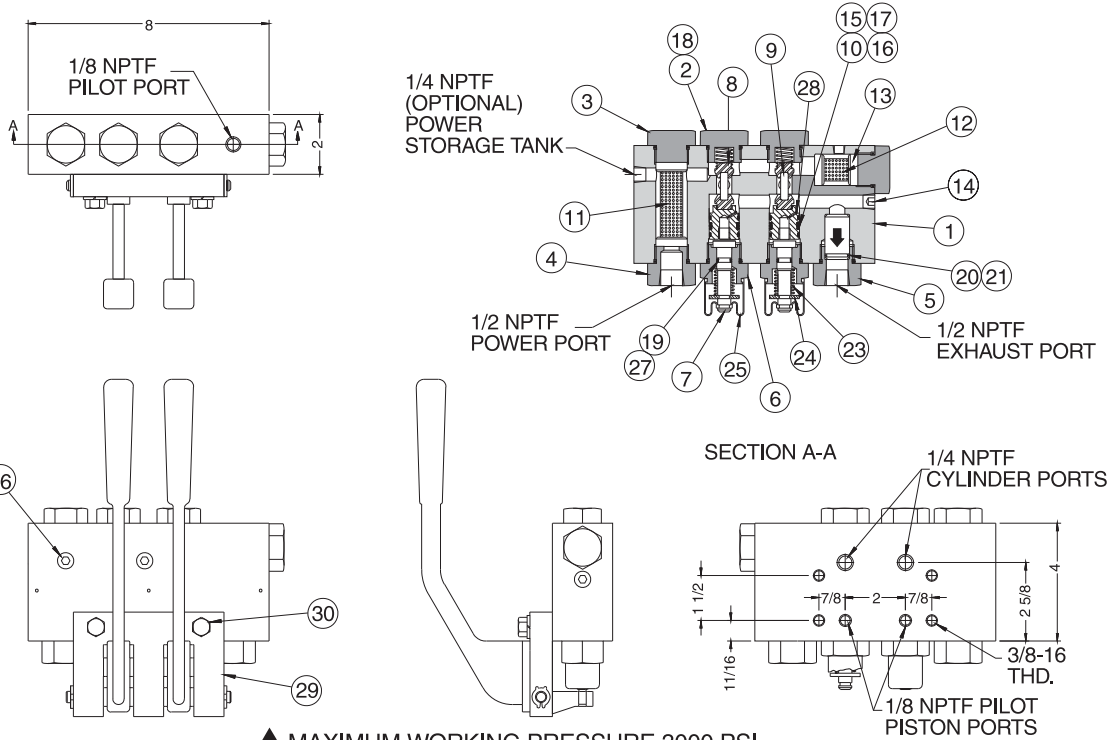

- ◆ MAXIMUM WORKING PRESSURE 3000 PSI
- ◆ MAXIMUM TEST PRESSURE 4500 PSI
- ◆ POPPET TRAVEL 1/16

ITEM	QTY.	DESCRIPTION	ITEM	QTY.	DESCRIPTION
1	1	Valve Body	15	2	Piston O-Ring
2	2	Power Poppet Cap	16	4	Piston Back Up Ring
3	2	Filter Cap	17	4	Piston Wear Ring
4	1	Power Connection Cap	18	8	Cap O-Ring
5	1	Exhaust Connection Cap	19	2	Stem O-Ring
6	2	Stem Cap	20	1	Check Valve O-Ring
7	2	Stem	21	1	Check Valve
8	4	Poppet (Nylon)	22	2	Power Poppet Spring
8*	2	Power Poppet (Neoprene)	23	2	Stem Spring
	2	Exhaust Poppet (Nylon)	24	2	"X" Washer
9	2	Poppet Pin	25	2	Stem Boot
10	2	Piston	26	2	Flush Plug
11	1	Strainer (Power)	27	2	Stem Back Up Ring
12	1	Strainer (Pilot)	28	2	Music Wire .018 Dia. x 1" Lg. S.S.
13	4	Strainer Seal	29	1	Manual Actuation Plate
14	1	Flush Plug	30	3	Actuation Plate Mtg. Bolts

* For low pressure applications

RECONDITIONING AND ASSEMBLY

RECONDITIONING

Power poppets have a raised boss for poppet spring engagement which may be grasped with pliers for easy removal. Do not pry poppets off pins with a screwdriver as damage to seats in the poppet block may result. Remove exhaust poppets from poppet pins.

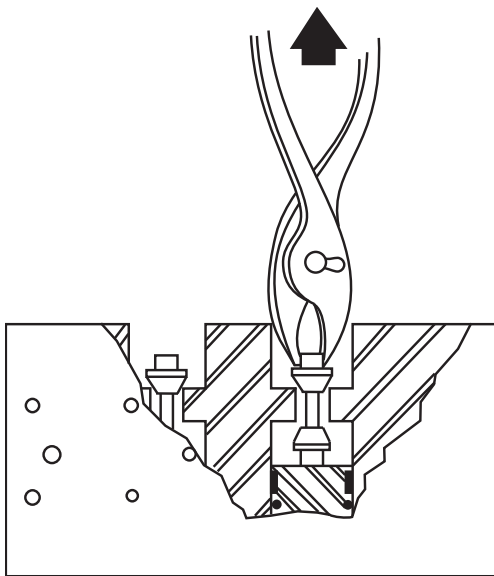

FIGURE A

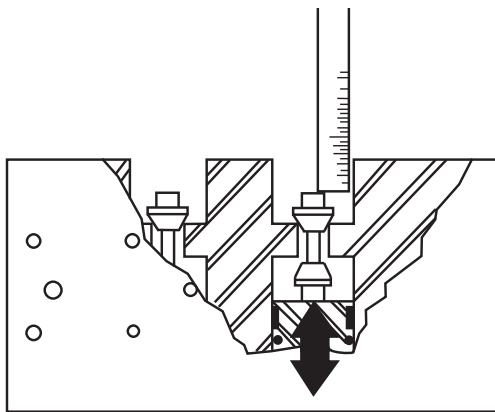

FIGURE B

ASSEMBLY

- 1) Thoroughly clean all components. Inspect seats in poppet block for nicks, scratches, pitting, etc.

NOTE: Seat reconditioning may be accomplished by polishing with an emery cloth. Care must be taken to maintain the radius at the outer edge of the poppet seat.

- 2) Replace power and exhaust poppets on poppet pins.

Poppets may be tapped lightly into position with a drift pin and light hammer.

- 3) Check travel of poppet assembly with the scale as shown in (Figure B). Make any adjustment for travel by grinding or filing to shorten the poppet pin or replace with a new pin if length is needed. Ref: 1/4" drill rod may be substituted for poppet pins in the 1/4" assembly and 1/2" drill rod for the 1/2" assembly. Adjust poppet travel to maintain 1/16" min. travel and 3/32" max. travel for both 1/4" and 1/2" assemblies (Poppet block size, 1/4" and 1/2", is designated by the diameter of the poppet connecting pin.)

- 4) Inspect and replace O-rings on pilot pistons. Place a small quantity of valve grease in poppet spring recesses on caps (2) to insure that springs stay in place during reassembly.

Replace poppet block caps (2) insuring power poppet bosses are engaged properly in poppet springs, replace caps (2), (6), levers, and bracket (29).

DISASSEMBLY OF THE POPPET BLOCK

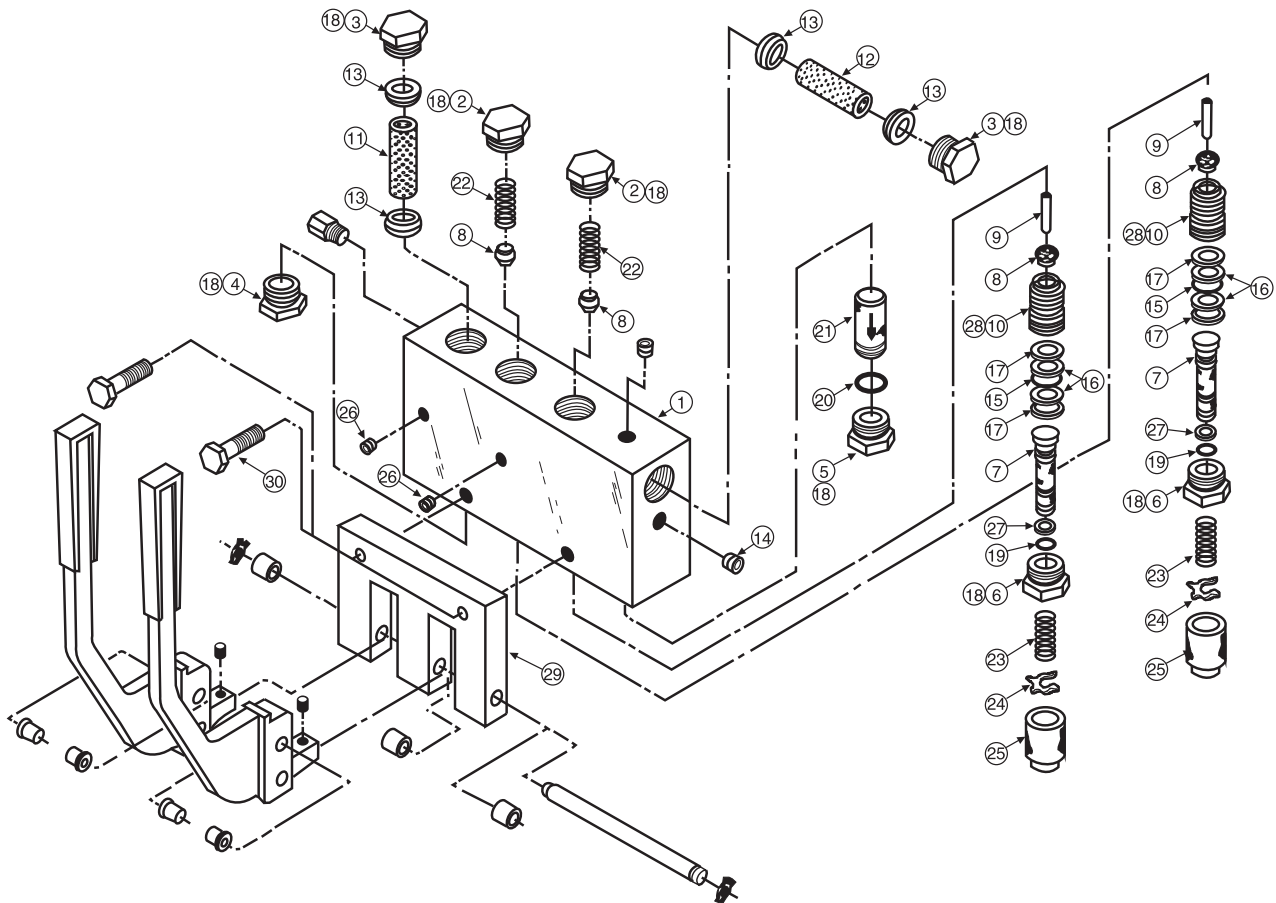

CAUTION: Turn off power gas, bleed off gas volume in power storage tank if so equipped, depress manual poppet - activating stem to vent any entrapped pressures.

NOTE: Isolate and disarm control. Assure availability of spare O-rings and poppets.

1) POWER POPPET REMOVAL:

Loosen poppet caps (2), remove springs (22) and power poppets (8).
(See reconditioning and assembly section for reinstallation.)

2) EXHAUST POPPET REMOVAL:

Disassemble the manual lever assembly by removing bolts (30) and bracket (29).
Loosen stem caps (6), remove stem assembly (7) and pilot pistons (10).

NOTE: Pilot pistons (10) can be removed by threading one of the hex bolts (30) into the back of the piston (10). Remove exhaust poppets and pins (8) and (9).

3) POWER STRAINER REMOVAL:

Piston cap (3) (on top of block), remove strainer seal (13) and strainer screen (11).

4) PILOT STRAINER REMOVAL:

Removal hex cap (3) on right side of poppet block. Remove strainer seal (13) and strainer screen (12).

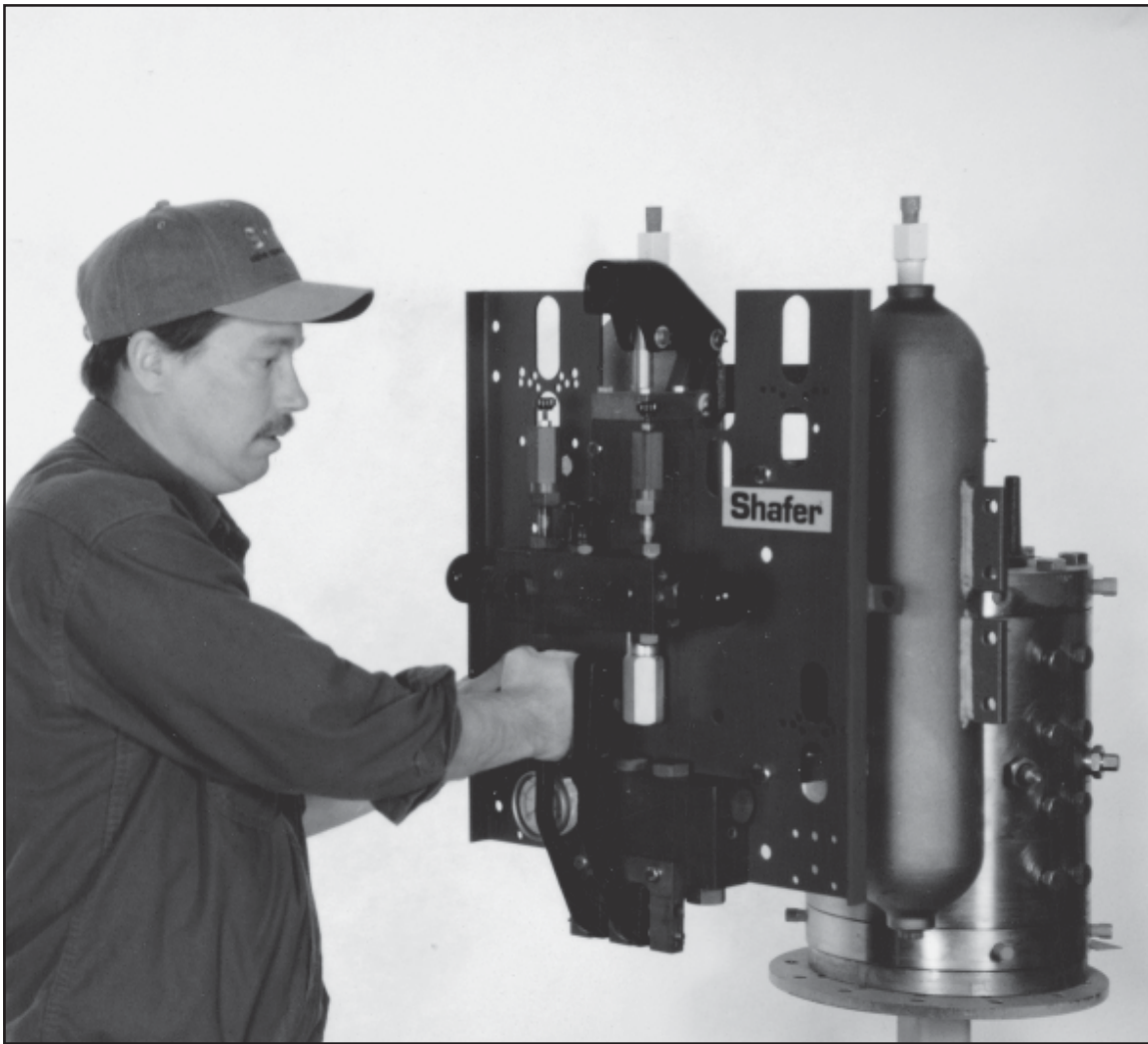

Emerson Process Management Valve Automation, Inc.

2500 Park Avenue West

Mansfield, OH 44906

Phone (419) 529-4311

FAX (419) 529-3688

www.emersonprocess.com/Shaffer

Shafer

EMERSON.
Process Management