

**Shafer™**

# LINEAR ACTUATOR

## INSTALLATION AND SERVICE MANUAL

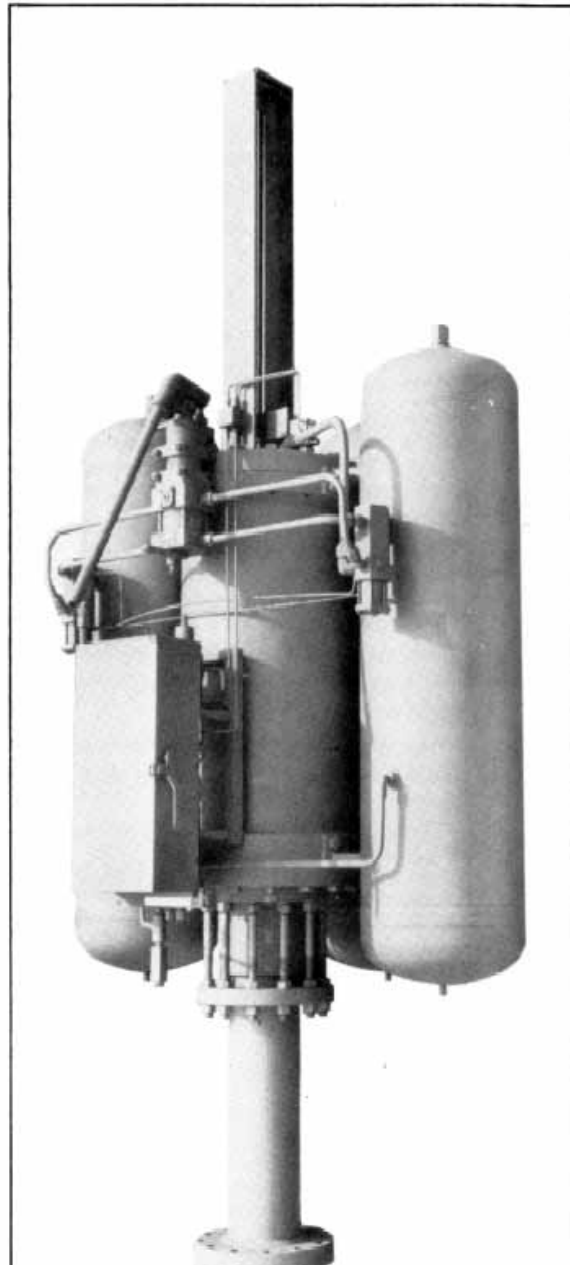
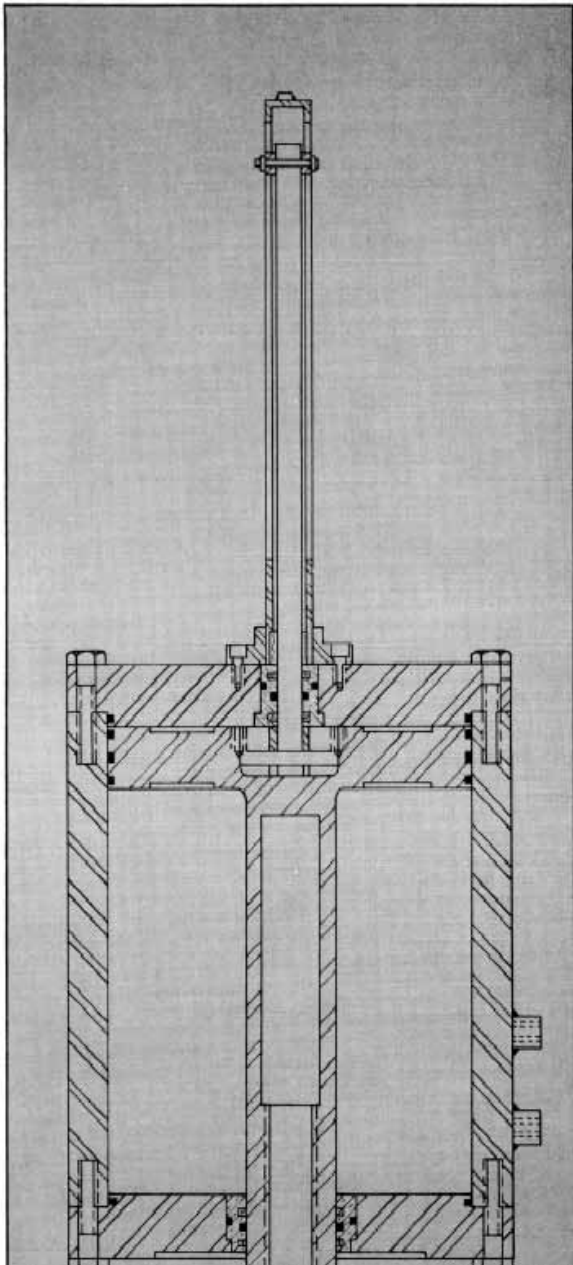

  
**EMERSON™**  
Process Management

# INSTALLATION INSTRUCTIONS

## VALVE PREPARATION

**Caution:** When a rising stem linear valve is under pressure, the pressure exerts an upward thrust on the area of the valve stem. This upward thrust is counteracted by the yoke nut, thrust bearings, and manual gear housing. When these items are removed, there is nothing to prevent the valve stem from being forced upward, possibly causing valve damage or personal injury.

It is for this reason, that if the valve is under pressure it must be placed in the full open position before attempting to install the Shafer Operator.

If the valve is not under pressure, it is advisable to place the valve in the closed position. This is true especially in the case of larger valves as it will prevent possible damage to the valve should the gate fall closed by its own weight.

### The Steps for Proper Valve Preparation Are:

1. If the valve is pressurized, stroke it to the full open position. If the valve is not pressurized, stroke it to the full closed position.
2. Remove the valve stem protective cover, if existent.
3. Remove the stem stop-nut from the end of the valve stem, if existent.
4. Remove the manual gear housing mounting bolts.
5. Turn the gear housing up and off of the valve stem, and remove all thrust bearings.

NOTE: For Grove Gate Valves with yoke tube extensions.

- A. Remove the mounting bolts and gear housing.
  - B. Remove the keyed torque tube.
  - C. Remove the yoke tube extension at point "X."
  - D. Remove the stem stop nut or downstop.
  - E. Remove the bearing housing from the yoke tube flange at "Y."
  - F. Remove the stem nut and thrust bearings from the valve stem.
  - G. Re-assemble the bearing housing to the yoke tube flange.
  - H. Re-assemble the yoke tube extension to the top of the bearing housing.
  - I. Shafer Linear Operators for Grove Gate Valves with yoke tube extension will be supplied with an operator stem extension the same length as the yoke tube extension for proper mating.
6. Thoroughly clean and generously grease the valve stem and mounting flange.

## OPERATOR PREPARATION

1. All certified drawings, accessory parts, bolts, etc. are packaged inside of the control box or attached to the operator or shipping crate.
2. All operators are designed specifically for horizontal or vertical stem mounting, but never for universal mounting.
3. The operator must be suspended in the proper position from a swivel-hook attached to the lifting device. The operator weight is equal to the valve size times 100 pounds. For example: 18" valve x 100 pounds = 1800 pounds.

**Caution:** Do not use chains to suspend the operator!

4. Remove the shipping plugs from the exhaust ports of the control junction block.
5. Check to make sure that the operator and valve are in the same relative position, I.E. both open or both closed.
6. The operator will be shipped in the open position. If the operator is to be mounted on a closed valve (non-pressurized), use the manual hand pump to stroke the operator closed while observing the position indicator markings on top of the operator.

## INSTALLATION PROCEDURE

1. After the valve and operator have been properly prepared, suspend the operator directly over the valve stem. The operator must be centered as near perfect as possible and parallel with the valve stem.
2. The female operator piston stem has approximately one inch of penetration before the internal thread begins to allow for ease in alignment.
3. Make note of whether the valve stem has a right hand or left hand thread.
4. Lower the operator until the stem threads meet. If an automotive winch is used, disconnect the distributor and use only the starter.
5. Carefully continue to lower while rotating the entire operator down over the valve stem until the mounting flanges meet.

NOTE: Care should be taken not to push (on open valves) or pull (on closed valves) the valve stem or operator piston from their original positions.

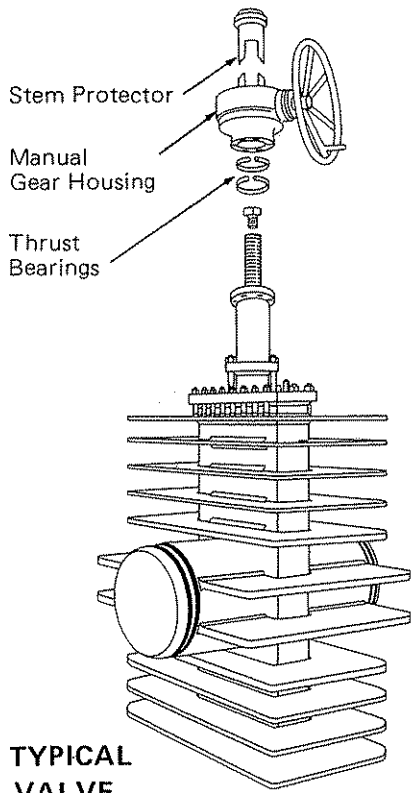

**TYPICAL VALVE**

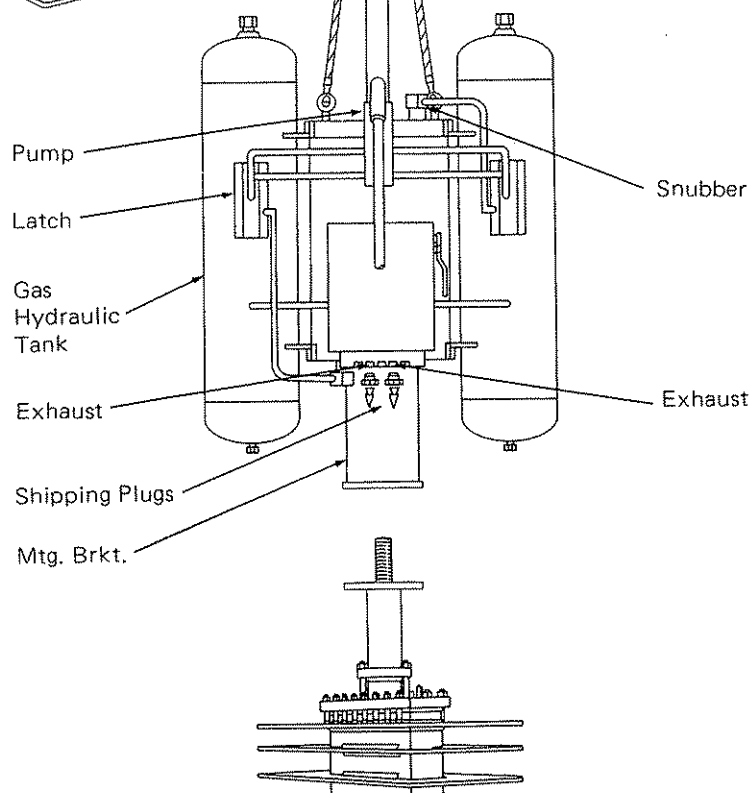
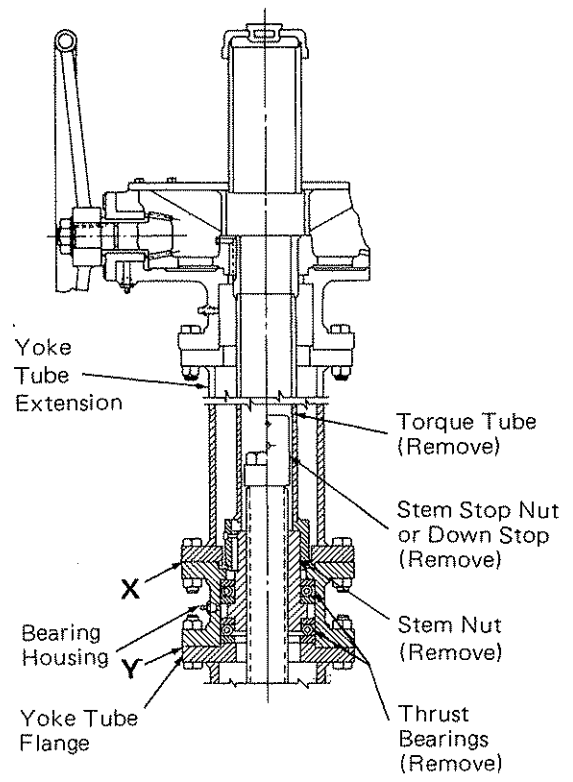

# INSTALLATION INSTRUCTIONS

## OPERATOR POSITION ADJUSTMENT

1. When the operator and valve flanges meet, it is possible that the control box does not face in the desired direction, and some position adjustment will be necessary.
2. Rotate the operator back until the control faces in the desired direction and the mounting flange holes are in alignment. This action will result in a gap between the operator and valve mounting flanges.
3. If the operator was mounted on a closed valve, at this time hand pump the operator fully open. Then using the lifting device, pull the operator and valve gate up until the gate is against its full open stops. If the gap between the flanges is greater than the distance of one complete turn of stem threads, turn the operator down until the flanges again meet, and then reposition the control as per step no. 2.
4. Loosely install the mounting bolts to maintain this desired position.
5. To close the gap between the flanges, observe the following directions: For operators with a two-piece telescoping mounting bracket see A, for operators with a one-piece non-adjustable bracket see B.
  - A. For telescoping two-piece bracket:
    1. Loosen the adjusting nuts (1) on the bottom of the middle flange of the telescoping bracket.
    2. This action will allow the lower piece of the mounting flange to slide down and make contact with the valve mounting flange.
    3. Tighten the operator mounting bolts in a standard criss-cross pattern applying the same torque to each to prevent any misalignment.
    4. Run the upper adjusting nuts (2) to within 1/8" of the top of the middle flange.
    5. Tighten the lower adjusting nuts (1) to the bottom of the middle flange pulling the bracket together 1/8" until the upper (2) and lower (1) adjusting nuts are tightly sandwiching the middle flange.

## B. For one-piece non-adjustable mounting brackets:

1. Remove the indicator guide pin and roller assembly from the top of the position indicator stem.
2. Remove the indicator guide tube retaining bolts and slide the guide tube up and off of the position indicator stem.
3. The top portion of the indicator is provided with a wrench hex. Grasp this hex and turn the piston further onto the valve stem until the gap is closed.

NOTE: While turning the piston, gently hand pump the operator towards the closed position to eliminate any hydraulic pressure below the piston.
4. Tighten the operator mounting bolts in a standard criss-cross pattern applying the same amount of torque to each to prevent misalignment.
5. Replace the indicator guide tube, retaining bolts, and roller and guide pin assembly.
6. Using the manual hand pump, stroke the valve fully open and closed. Measure and compare the travel of the position indicator with the specified valve travel (which is listed on the Certified Drawings) to insure that the valve is reaching its full end of stroke position with out overtravel.

## CUSTOMER CONNECTIONS

1. All electrical and control tubing connections are pointed out on the certified drawings and schematic drawings found in the job folder.

NOTE: The exhaust ports must never be restricted through piping smaller than the pipe thread size of the port on the junction block. On some of the larger gas-powered linear operators there are two exhaust ports. These must never be manifolded together.

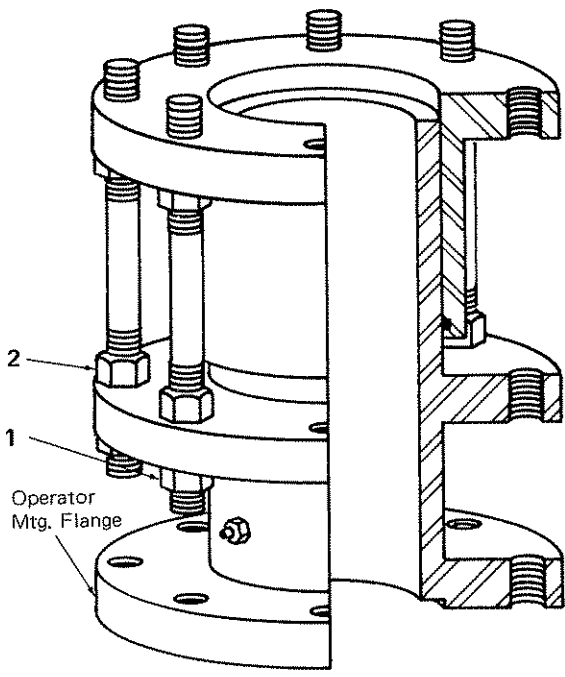
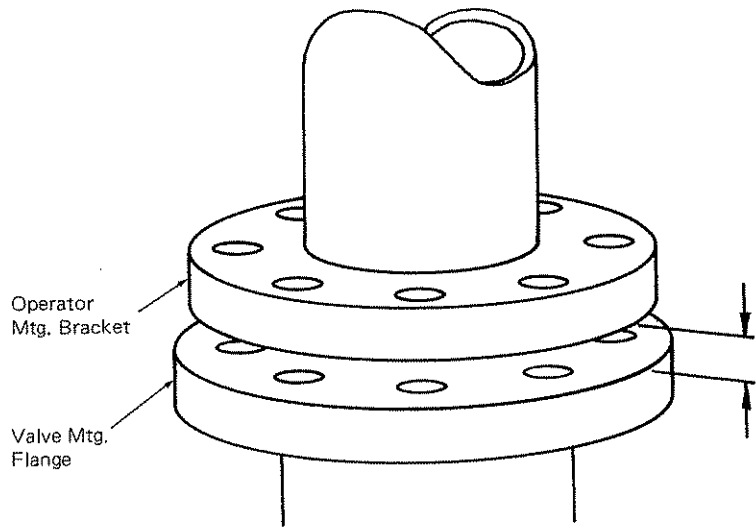

**A**  
**TWO-PIECE**  
**TELESCOPING**  
**BRACKET.**

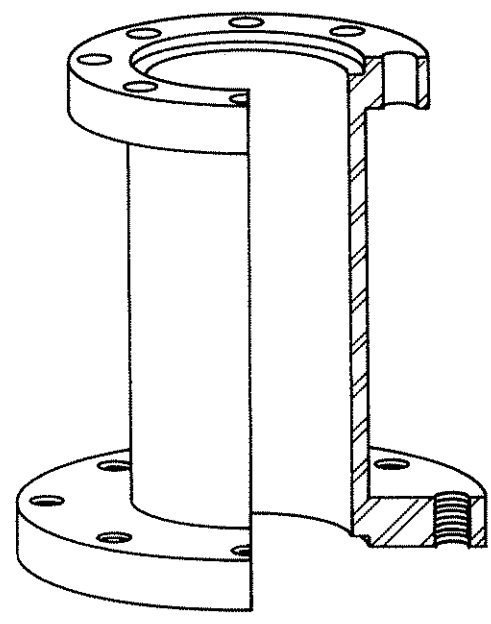

**B**  
**ONE-PIECE**  
**NON-ADJUSTABLE**  
**BRACKET.**

# CONSTRUCTION

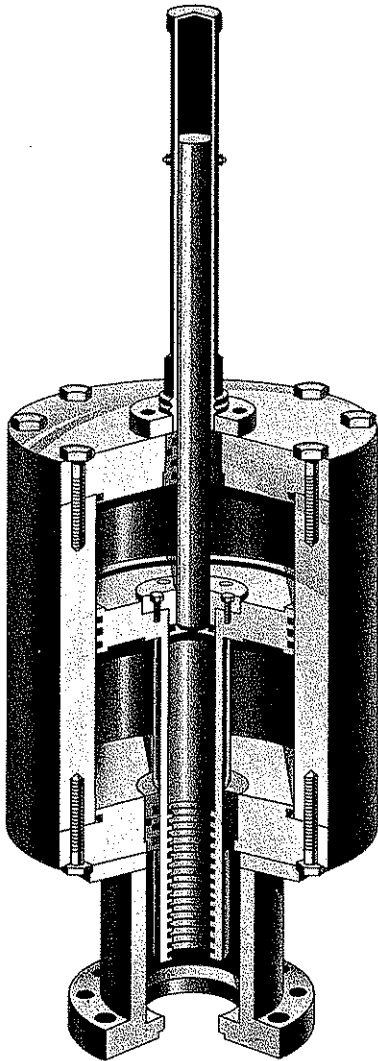

## CONSTRUCTION

- Simple, basic design with no power-absorbing gearing. Hydraulic piston principle provides fast, smooth operation—without shock
- Made from high quality steel plate, ground to precision tolerances
- Composition seals and fiber wipers assure leakproof operation at high pressure
- Low friction bearing surfaces are provided by a bronze coating on the piston diameter and bronze bushings in the heads
- Piston is threaded to valve stem
- Mounting bracket machined to fit valve bonnet or yoke tube
- Special latch device provided to lock the valve in any position desired
- Snubbers installed for wedge type gate valves

## HYDRAULIC FLUID SPECIFICATIONS

The following tables show recommended hydraulic fluids for all Shafer Operators.

### FOR WARM WEATHER: 20° F to 120° F

API Gravity	31.1
Viscosity at 210° F	45.2 SSU
Viscosity at 100° F	115. SSU
Viscosity at 0° F	1600. SSU
Pour Point	-50° F
Viscosity Index	150
Flash Point	335° F
Fire Point	350° F
Base Pa	Parrafin
Inhibitors	Rust-Foam Oxidation
Color	1
Neutralization No.	.07

### FOR COLD WEATHER: -40° F to 100° F

API Gravity	32.8
Viscosity at 210° F	42.9 SSU
Viscosity at 110° F	74. SSU
Viscosity at 0° F	360 SSU
Pour Point	-75° F
Viscosity Index	225
Flash Point	215° F
Fire Point	250° F
Base	Petroleum
Inhibitors	Rust-Foam Oxidation
Color	16.5 (red)
Neutralization No.	.03

### NOTE:

- (1) Consult factory for temperatures below -40° F.
- (2) Viscosity of hydraulic fluid used may affect operator movement and restrict hand pump suction. For these reasons the above fluid specifications are recommended.
- (3) Do not use motor oils purchased at gasoline stations. Most motor oils contain sulfur which is corrosive, and other additives which will produce a varnish like coating on the mirror-like interior of the operator.

# BASIC OPERATION

## OPERATION

The operator may be powered by line pressure, stored gas pressure, or by a central hydraulic system. Designed specifically for gate valve installations, Shafer Linear Operators feature a special double latch for locking the valve into any desired position.

## SEQUENCE 1

For this explanation the operator is shown fitted with gas hydraulic tanks and will be powered by pipeline pressure. The operator is shown in the full open position with no pressure in the operator or tanks.

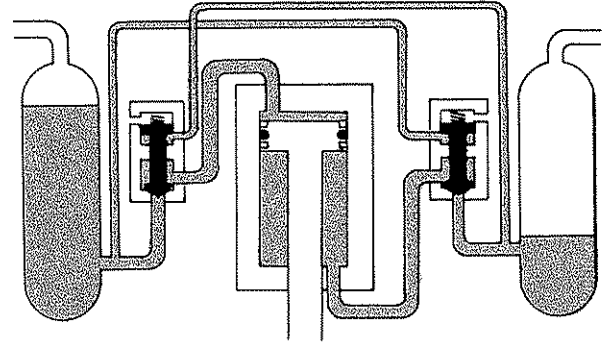

VALVE FULLY OPEN

## SEQUENCE 2

Line pressure is admitted to the closing gas hydraulic tank. The pressurized hydraulic fluid flows out of the tank and under the poppet of the closing latch. The poppet is forced off of its seat and allows the pressurized hydraulic fluid to flow to the top of the operator piston.

A separate hydraulic line is ported to the opening latch. The pressurized hydraulic fluid enters under the piston of the opening latch which pulls the opening poppet off of its seat.

As the pressurized hydraulic fluid forces the operator to the closed position, the fluid under the operator piston is pushed out of the operator, through the opening latch, and into the opening gas hydraulic tank.

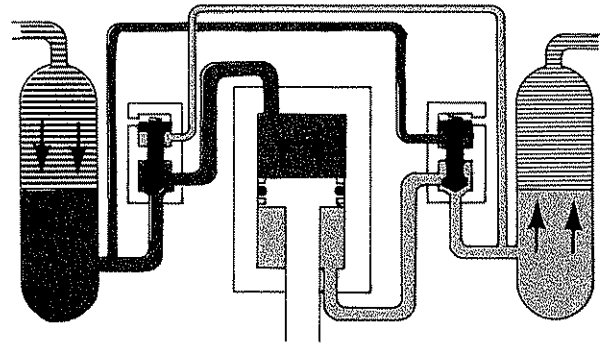

VALVE CLOSING

## SEQUENCE 3

When the operator reaches the fully closed position, the control will neutralize and allow all remaining line pressure to vent to atmosphere, thus neutralizing tank and operator pressure.

When the pressure is neutralized, the latches, being spring actuated, will automatically close and lock the hydraulic fluid both above and below the operator piston. Because the hydraulic fluid is non-compressible, the operator will maintain the closed position.

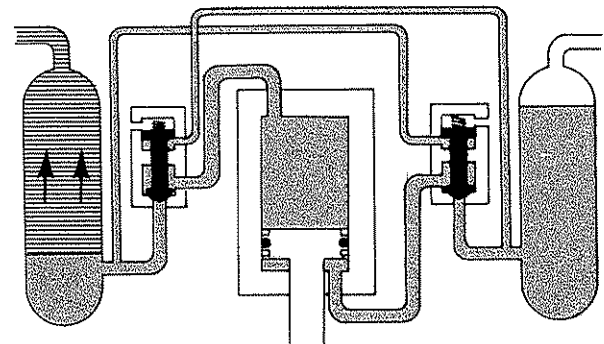

VALVE FULLY CLOSED

# LATCHES & SNUBBERS

## THE HYDRAULIC LATCH

### PURPOSE:

As previously stated the hydraulic latch is a means to lock hydraulic fluid both above and below the operator piston which in turn maintains the desired position of the valve. Without the latches, pipeline pressure acting on the area of the valve stem would force the valve and operator open.

### OPERATION:

The latches can be unseated in three ways:

1. When using pipeline pressure to power the operator, the hydraulic fluid from the pressurized tank is ported to the bottom of the latch at I. The pressurized hydraulic fluid acting on the seating area of the poppet A forces the poppet off its seat allowing the hydraulic fluid to enter the operator from port II.
2. Port III. is connected to port IV of the opposite latch. The pressurized fluid acting as a pilot on the latch piston pulls the opposite latch off of its seat allowing the fluid in the operator to flow to the non-pressurized receiving tank.
3. The latches act as relief valves should thermo-expansion occur. The hydraulic fluid locked between the operator and the latch when subjected to heat will increase in pressure. The pressure will continue to rise until the force created by this pressure acting on the difference in area between A and B, the area of the poppet stem, is sufficient to overcome the force of the spring compression. The poppet will then be unseated allowing one or two drops of hydraulic fluid to relieve to the gas hydraulic tank. When the pressure is relieved, the spring force will reseat the poppet.

### ADJUSTMENT OF THE LATCHES

It must be remembered then, that the spring compression must be sufficient enough to:

1. Allow stroking the operator with the hand pump without relieving.
2. Lock the operator in any desired position against the natural upward thrust of the valve.

And yet, the spring compression cannot be so great as to prevent:

1. The minimum working power pressure from unseating the poppet when using power gas to stroke the operator.
2. The pressure from thermo expansion from relieving, which could cause damage to the operator.

## MAINTENANCE OF THE LATCH

NOTE: The spring cavity in the tops of the latches must be examined for condensation accumulation always before freezing weather. If sufficient water freezes at this point, the latch will not function which will prevent the operator from functioning in the automatic sequence.

1. The operator must always be in the open position before the latches can be disassembled.
2. Remove the adjusting screw cover 5.
3. Measure and note the distance from the top of the latch head to the top of the adjusting screw 6.
4. Remove the adjusting screw with a large screwdriver.
5. Remove, clean, and grease the spring 8.
6. Remove the body retaining bolts 14, and upper head 1.
7. Remove the upper cylinder 2, and the piston and poppet assembly 4 and 9.
8. Inspect the seating area of the poppet and seat for any scratches or nicks. (The body seat can be cleaned and polished with crochus and emery cloth).
9. Replace seals and poppet if necessary.
10. Clean and grease all parts.
11. Reassemble in reverse order making sure that the adjusting screw is "run in" to the pre-measured depth from step no. 3.

## THE HYDRAULIC SNUBBER

Wedge type gate valves are supplied with a hydraulic snubber in the upper and lower heads of the operator. The purpose of the snubber is to reduce the speed of the operator and valve mass so as to prevent the wedge from being jammed into the valve seats at the end of stroke. In the last 1/2 inch of travel, the piston contacts the internal portion of the spring loaded snubber. As the piston continues towards the head, the snubber is forced into its seat and continues to restrict the flow of fluid out of the operator, thus causing the braking action. The snubber is also used on ultra high-speed operators to prevent shock by buffering the end of stroke momentum.

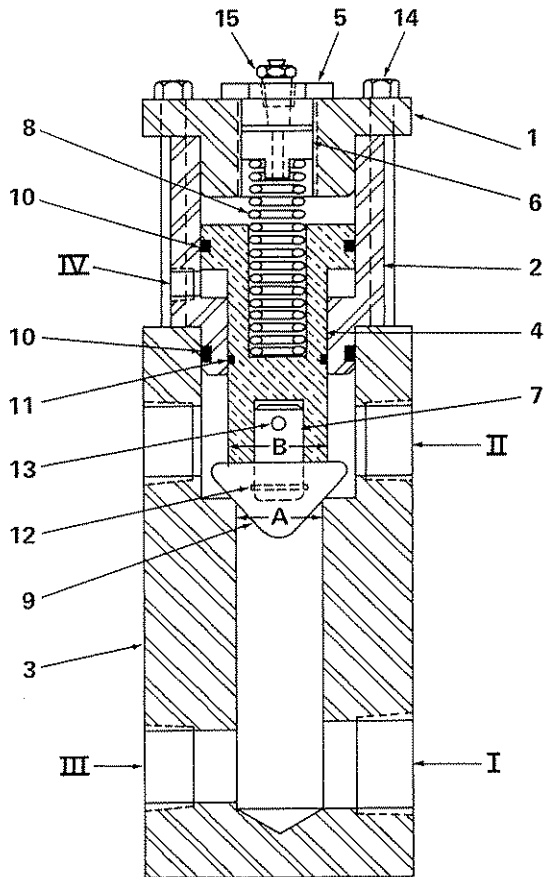

### HYDRAULIC LATCH

BILL OF MATERIAL		
Item	Quan.	Description
1	1	Head
2	1	Upper Body
3	1	Lower Body
4	1	Piston
5	1	Adjusting Screw Cap
6	1	Adjusting Screw
7	1	Latch Pin
8	1	Spring
9	1	Neoprene Disc.
10	2	O-Ring Linear *11-224
11	1	O-Ring Linear *11-024
12	1	Truarc Snap Ring No. 5103-62
13	1	Sps. 187 Spring Pin 1-3/16 Lg.
14	6	5/16-18 x 3-1/2 Hex. Hd. Cap Scr.
15	1	1/18" Alemite Relief Fitting No.

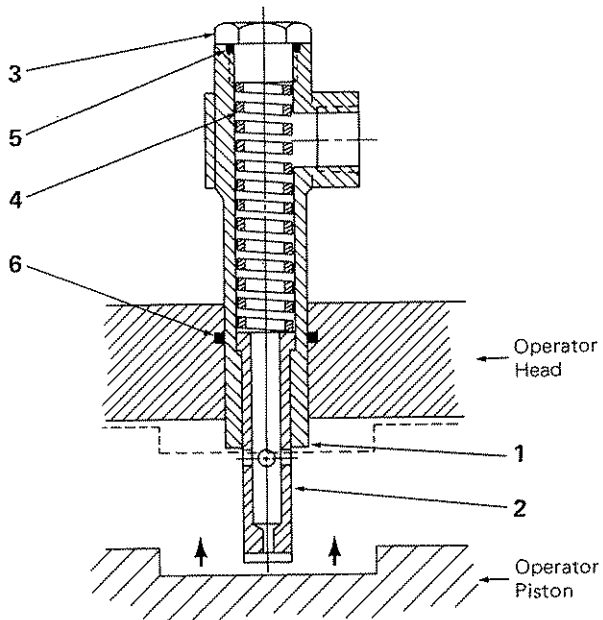

### HYDRAULIC SNUBBER

BILL OF MATERIAL		
Item	Quan.	Description
1	1	Body
2	1	Plunger
3	1	Body Cap
4	1	Spring MP-39
5	1	O-Ring PRP-568-116
6	1	O-Ring PRP-568-215

# PURGING

## PURGING & DRAINING

A properly purged and periodically drained operator will retain its mirror-like interior and extend its seal life by preventing the possibility of corrosion and galling. For proper operation and maintenance, the operator must be completely filled with hydraulic fluid, both above and below the operator piston.

The following observations would indicate that the operator is not completely full of hydraulic fluid:

1. Delayed or erratic movement of the operator when using power gas.
2. "Sponginess" when using the hand pump.
3. Valve drift or "creep" from the desired position.

## PURGING PROCEDURE

To rid the operator of gas and restore it to proper operation, follow these steps.

1. Place the operator in the full open position.
2. CAUTION: Disarm the control from the operator by first turning off power gas. Then remove the pivot pin of the control rocker arm to prevent any remote signals from actuating the control, and remove the bull plugs from the tops of the gas-hydraulic tanks.
3. Fill the closing gas hydraulic tank to the upper weld ring on welded tanks, or the upper radius on spun tanks, as per Figure No. 1.
4. Place the selector lever of the hand pump in the closed position and slowly pump the operator fully closed.
5. Fill the opening gas hydraulic tank to the upper weld ring on welded tanks, or upper radius on spun tanks, as per Figure No. 2.
6. Place the selector lever of hand pump in the open position and slowly pump the operator fully open.
7. Return the selector lever of the hand pump to the mid, or automatic, position.
8. The operator has now been properly purged and, after proper oil levels are established in the gas hydraulic tanks (page 12), the bull plugs can be reinstalled and the control re-armed.

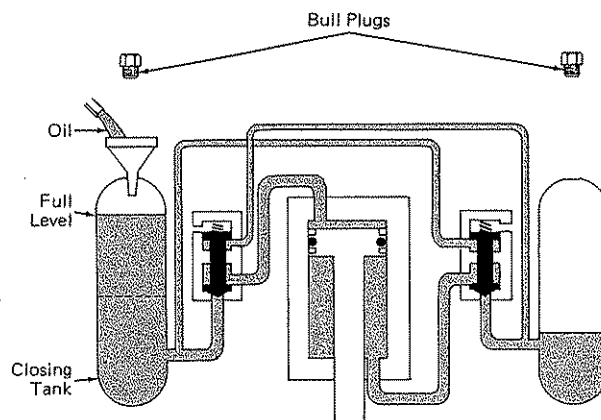

VALVE FULLY OPEN

FIGURE NO. 1

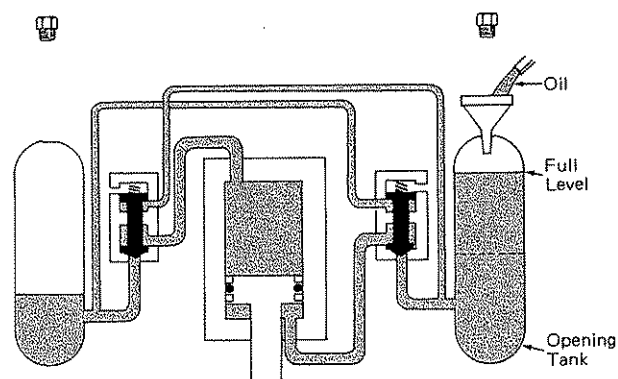

VALVE FULLY CLOSED

FIGURE NO. 2

# DRAINING

## DRAINING PROCEDURE

The operator and tanks should be periodically inspected and drained to remove any accumulation of condensate and foreign matter. The frequency of this maintenance procedure is dependent of the wetness of the power gas, and certain climatic conditions. But, always drain the operator before freezing weather sets in.

To properly drain the operator:

1. **CAUTION:** Disarm the control from the operator by first turning off power gas. Then remove the pivot pin of the control rocker arm to prevent any remote signals from actuating the control, and remove the bull plugs from the top of the gas hydraulic tanks.
2. Loosen, but do not completely remove, the bull plugs at the bottom of the gas hydraulic tanks and allow the water and contaminants to drain. When clear hydraulic fluid appears, retighten the bull plugs, as per Figure No. 1.
3. Loosen, but do not completely remove, the hydraulic tubing fitting at the bottom of the operator and allow the water and contaminants to drain. When clean hydraulic fluid appears, retighten the fitting, as per Figure No. 1.
4. To drain the upper portion of the operator, it must be in the fully open position.
5. With the operator in the open position, completely remove the hydraulic fitting or snubber, whichever is existent.
6. Insert a flexible siphon through the upper port to reach the accumulation of contaminants laying in the dished out portion of the piston. Pour in clean hydraulic fluid and replace the fitting or snubber.
7. After draining the operator and tanks of contaminants, use the above purging procedure to fill the operator for normal operation.

It is recommended that the hydraulic fluid be changed completely every five years. This can be accomplished as follows:

1. **CAUTION:** Disarm the control from the operator.
2. With the operator in the open position, drain the closing gas hydraulic tank, and fill with new hydraulic fluid. Then, hand pump the operator to the fully closed position.
3. Drain the opening gas hydraulic, and fill with new hydraulic fluid.
4. Re-arm the control for normal operation.

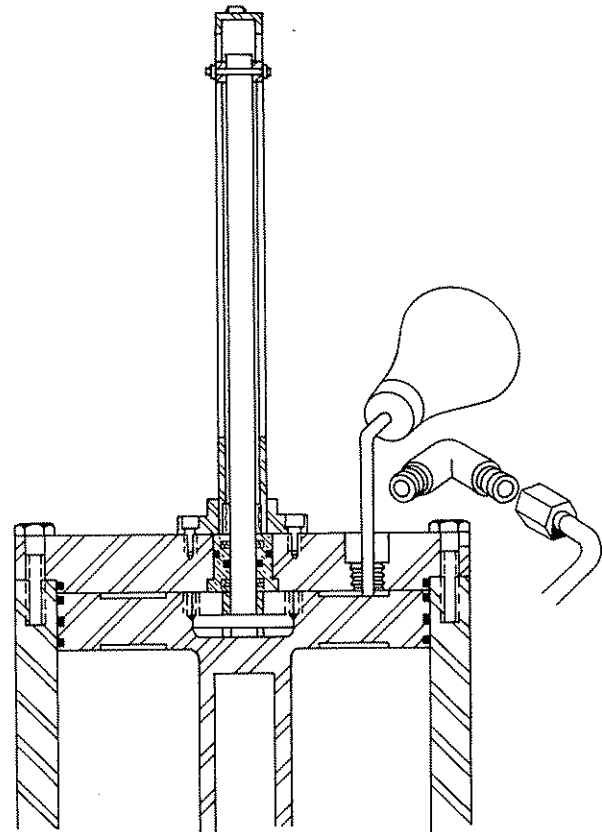
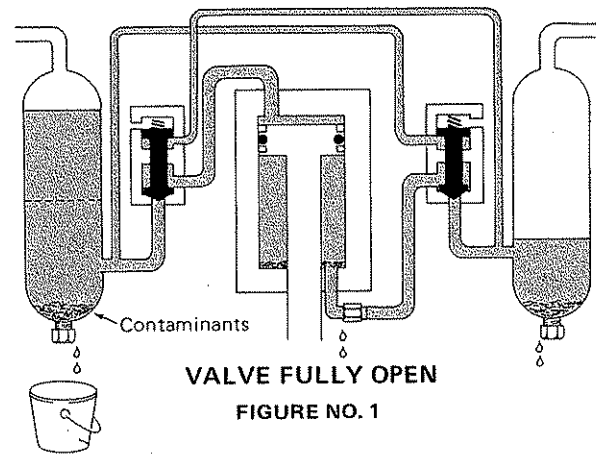

# PROPER OPERATING OIL LEVELS

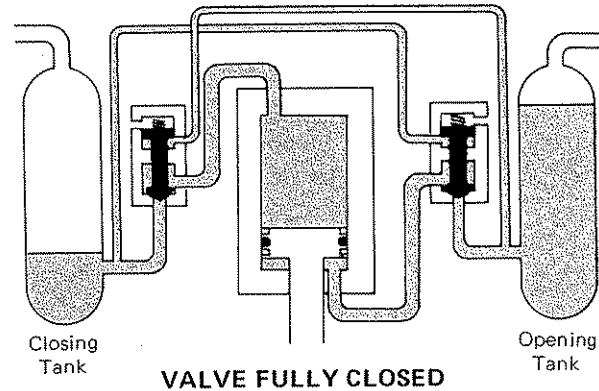
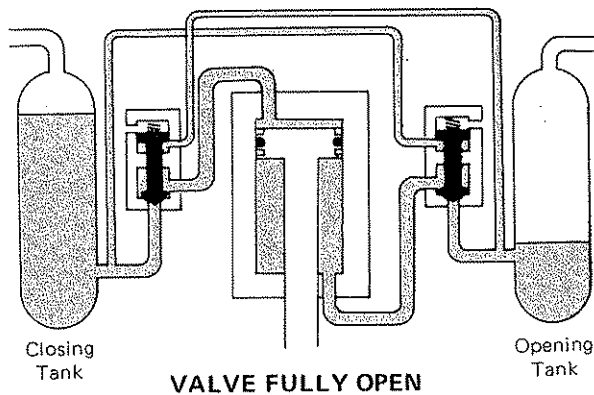

**NOTE:** For best results, the operator should be purged of any trapped gas before proceeding with the establishment of proper oil levels in the gas hydraulic tanks.

All linear valve operators are equipped with 1-1/4 volume tanks. This means that each tank will hold 1-1/4 times the amount of oil needed to stroke the particular operator.

The proper operating oil levels are as follows:

1. If the operator is in the open position, the closing or "ready" tank should be filled to the upper weld ring, and the opening or "receiving" tank should be filled 2 to 4 inches above the lower weld ring.
2. If the operator is in the closed position, the opening or "ready" tank should be filled 2 to 4 inches above the lower weld ring.
3. Any excess oil will spill out of the exhaust port with the next cycling of the operator.

Continued or excessive need to re-establish the proper oil levels is usually a result of one or more of the following:

**CAUSE I**—Improper use of the hand pump when pumping the operator open.

**SOLUTION I**—The operator in some cases will drift open on its own as soon as the hand pump selector lever is moved to the open position. This situation is not detrimental to the proper oil levels if the selector lever is completely "snapped in" the open position. However, DO NOT attempt to control the speed of the upward drift by "throttling" the selector lever between the mid and open positions as this action causes improper transfer of hydraulic fluid in the tanks.

**CAUSE II**—Leakage in the sealing areas of the hand pump.

**SOLUTION II**—Refer to the "Manual Hand Pump Maintenance & Service Manual" for proper maintenance.

**CAUSE III**—Leakage across the operator piston seals.

**SOLUTION III**—Replace the operator seals as per this manual.

# DISASSEMBLY

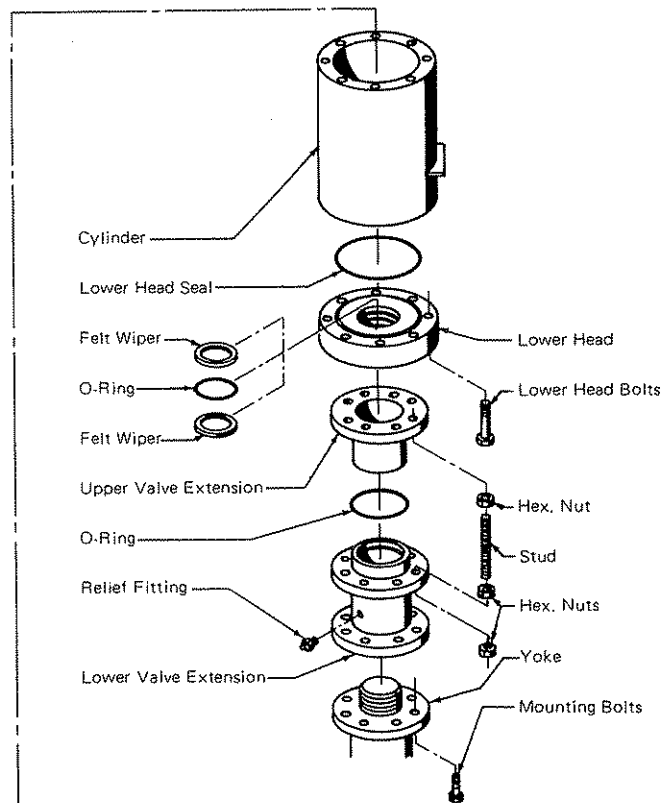
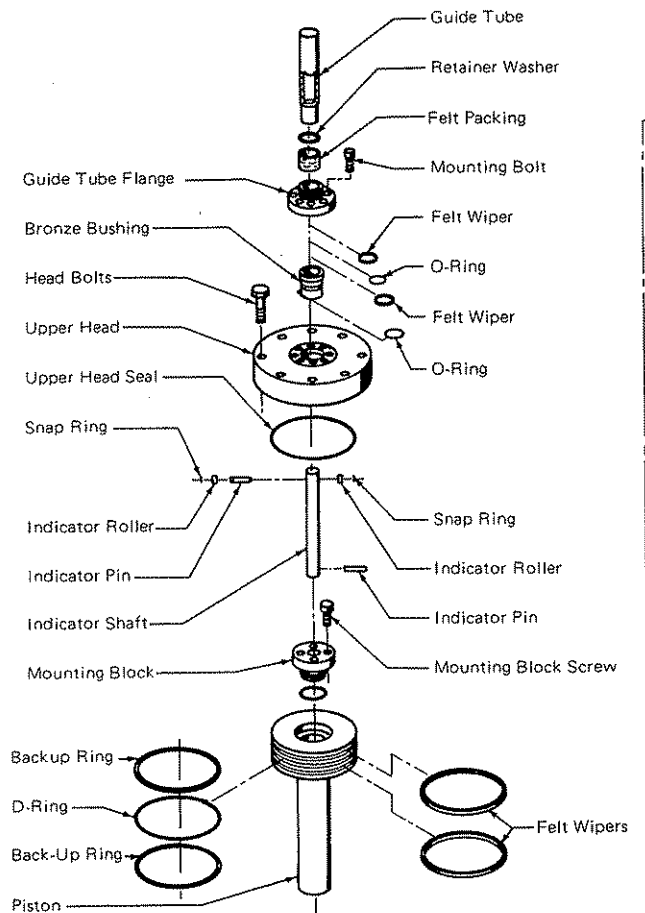

## DISASSEMBLY

NOTE: Make certain that a complete set of replacement seals is available before attempting disassembly.

NOTE: The operator must be removed from the valve before disassembly can be accomplished.

CAUTION: The valve must be in the fully opened position, if there is pressure in the pipeline, before the operator can be removed.

## DISASSEMBLY PROCEDURE

1. After being removed from the valve, support the operator in an upright position and drain the hydraulic fluid.
2. If limit switches or trigger valves are existent, they must be removed from the upper head.
3. Remove the guide pin and roller assembly.
4. Remove the guide tube flange retaining bolts, and slide the guide tube off of the indicator stem.
5. Remove the upper head bolts.
6. Install lifting eye bolts in the upper head and pull the head from the operator.
7. Pull the piston from the cylinder by installing eye bolts in the lift holes provided.

# RECONDITIONING AND REASSEMBLY

## RECONDITIONING:

Thoroughly clean all components and inspect the cylinder for scoring, galling, and corrosion, all of which are indications that the operator has not been properly maintained.

Use fine emery cloth to remove any disfigurations or corrosion followed by a final polishing with crochus cloth. Remember, the operator's cylinder is a sealing surface, and must be smooth to seal properly and prevent damage to the new seals.

Replace all seals, back-up rings, and wipers. The replacement seals may be ordered simply by specifying the operator's serial number. Lubricate all surfaces and seals with a light grease before reassembly. Remember, all seals should be replaced as they are less expensive than the man-hours involved in reassembling the operator using the old existing seals, and then discovering a seal to be faulty.

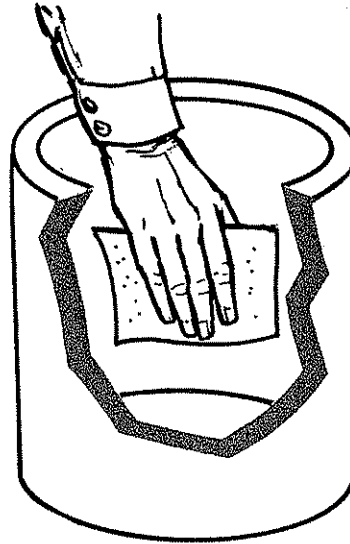

## REASSEMBLY:

Once the operator has been reconditioned and fitted with new, well-lubricated seals, proceed as follows:

1. Slowly lower the piston into the cylinder. A rubber mallet can be used to position the piston into the cylinder, as there will be slight resistance caused by the seal compression. Be careful not to damage the seal or back-up ring in this step.
2. Replace the upper head and tighten the head bolts using the standard criss-cross torque method.
3. Replace the guide tube and flange assembly, retaining bolts, and guide pin and roller assembly.
4. If limit switches or trigger valves were removed, replace them at this point.
5. Refill the operator using the purging procedure as described on page 10 of this manual.
6. Re-install the operator to the valve as per pages 2, 3 and 4 of this manual.

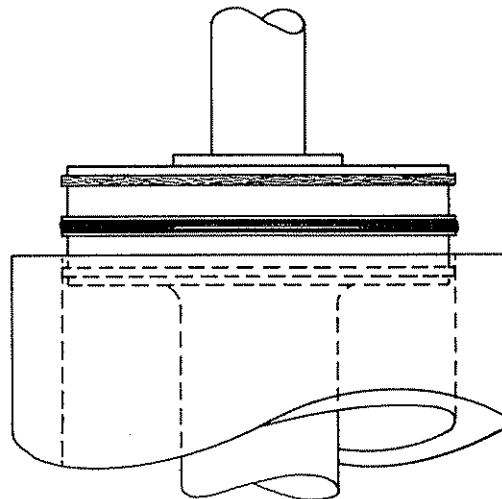

# TROUBLE SHOOTING CHECK LIST

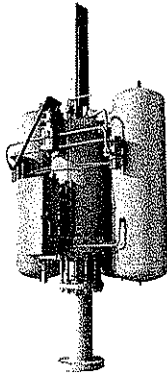

## TROUBLE SHOOTING CHECK LIST

If a particular problem should arise, it is wise to trouble shoot starting with the various components of the system, because most always the operator itself will be the last source of trouble. In other words, it takes more man-hours to pull the head of an operator thought to contain bad seals than it does to recondition the hydraulic latch where the problem really exists. The following are the problems that might arise, their causes, and what steps to take to correct the situation.

**PROBLEM 1**—Spongy, erratic, or faster than normal operation.

**PROBABLE CAUSE**—Lack of hydraulic fluid in the operator.

**SOLUTION**—Purge the operator of all gas and foam and establish proper oil levels as indicated in this manual on pages 10 and 12.

**PROBLEM 2**—Operator moves too slowly.

**PROBABLE CAUSE**—Speed controls, if existent, are pinched too far.

**SOLUTION**—Open speed controls to allow more flow.

**PROBABLE CAUSE**—Use of improper hydraulic fluid.

**SOLUTION**—Refer to proper hydraulic fluid tables in this manual on page 6.

**PROBABLE CAUSE**—Restriction of exhaust port of control.

**SOLUTION**—Check to make sure exhaust port is clear, and if exhaust is manifolded away that tubing size or length does not cause restriction and back pressure.

**PROBABLE CAUSE**—Restriction of power gas because of:

- A. Low gas pressure.
- B. Ice in system causing blockage.
- C. Dirt, grease, or contaminants in control strainers.
- D. Power gas connecting lines from pipeline to control too small in diameter.
- E. Shafer control out of adjustment.

**SOLUTION**—Refer to the Shafer Poppet Block Control Maintenance and Service Manual.

**PROBLEM 3**—Operator will not move valve.

**PROBABLE CAUSE**—Low power pressure or valve thrust requirements exceed operator thrust output.

**SOLUTION**—Raise power pressure if possible, and recheck the valve thrust requirements. In some cases the manual hand pump can be used to create more hydraulic pressure.

**NOTE:** Valve body distortion, whether by pipeline force or thermal force, can cause the valve to tighten either permanently or at certain times of the day.

**PROBABLE CAUSE**—Operator and valve are not in the same relationship.

**SOLUTION**—Check to insure that an open operator has been installed on an open valve. If not, the operator will have to be properly re-installed.

**PROBABLE CAUSE**—Valve is stuck.

**SOLUTION**—Remove the operator from the valve and use the hand pump to stroke it. If the operator strokes independently from the valve, consult the valve manufacturer.

**PROBLEM 4**—Operator drifts or creeps toward the open position, or if the operator cannot be stroked when using the hand pump.

**PROBABLE CAUSE**—Lack of hydraulic fluid.

**SOLUTION**—Purge the operator of all gas and foam and establish proper operating oil levels as per this manual on pages 10 and 12.

**PROBABLE CAUSE**—Malfunction of hand pump.

**SOLUTION**—Refer to the Shafer Hand Pump Maintenance and Service Manual.

**PROBABLE CAUSE**—Malfunction of the hydraulic latch caused by leakage.

**SOLUTION**—Disassemble the latches, recondition all sealing surfaces, and replace all seals and the neoprene poppet. Reassemble the latch and re-install.

**PROBABLE CAUSE**—Failure of operator piston seals.

**SOLUTION**—After all other factors have been eliminated as the cause of trouble, it is necessary to recondition the operator as per this manual.

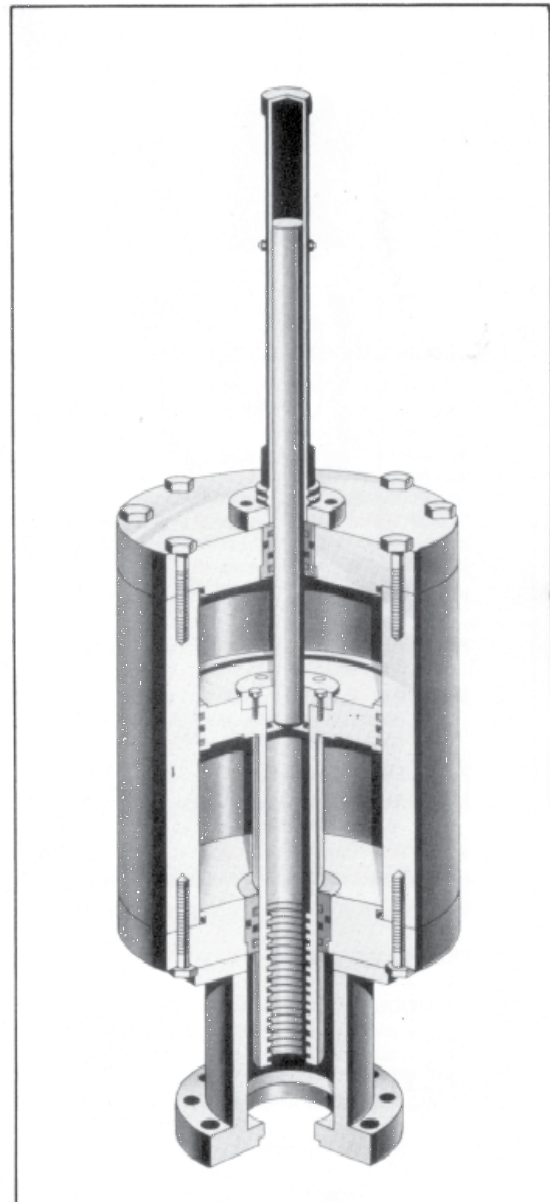
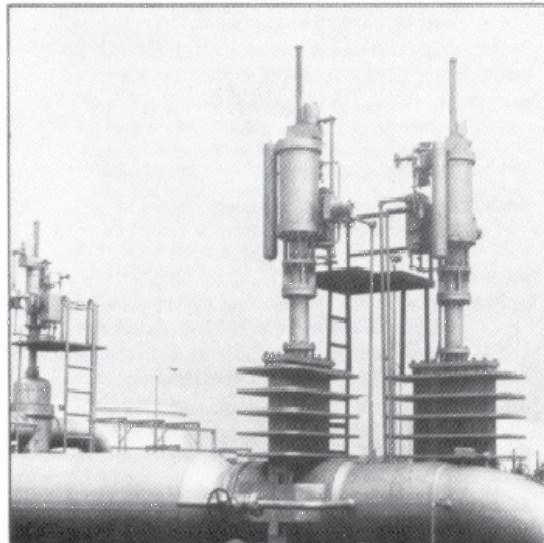
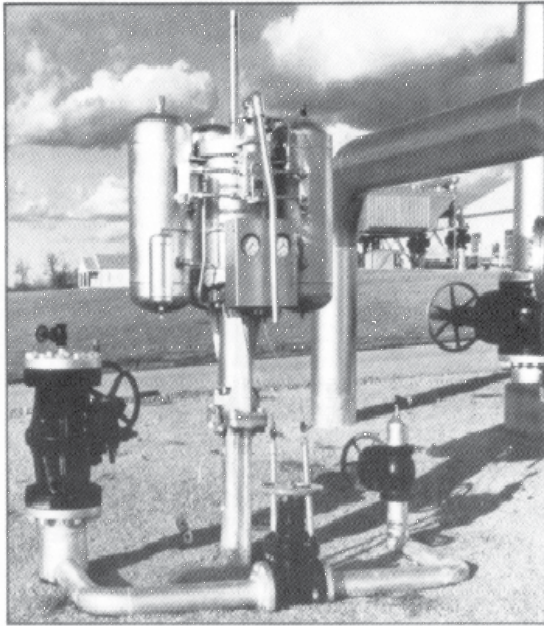

SHAFFER VALVE COMPANY  
2500 Park Avenue West  
Mansfield, OH 44906  
Phone (419) 529-4311  
FAX (419) 529-3688

[www.shafervalve.com](http://www.shafervalve.com)

**Shafer™**

  
**EMERSON.**  
Process Management

LSM-01102001