

MOD H30: Installation Procedure

HP/HYD/INST

05-04-11

Shafer Hand Pump

Installation Procedure on a Rotary Vane Actuator with Central Hydraulic System

MOD H30: Installation Procedure

HP/HYD/INST

05-04-11

The purpose of this procedure is to guide the installation of a Shafer Hand Pump to an existing Rotary Vane Actuator.

This procedure is to be used in conjunction with the following Maintenance and Service Manual.

Manual Shafer Hand Pump Maintenance and Service	Bulletin MHP-01102001

WARNING: 1. Turn power oil supply off and bleed off pressure.



2. Close the valve in the return line.

1. Remove tubing from the lower fittings in the hand pump going to the control.
2. Remove tubing from hand pump to actuator.
3. Remove the old hand pump.
4. If the old hand pump was tubed to the side of the actuator, as shown in Figure 1, remove the plugs in the upper head, directly above the side ports. Clean the threads of the plugs; apply an appropriate pipe sealant and plug the side ports.

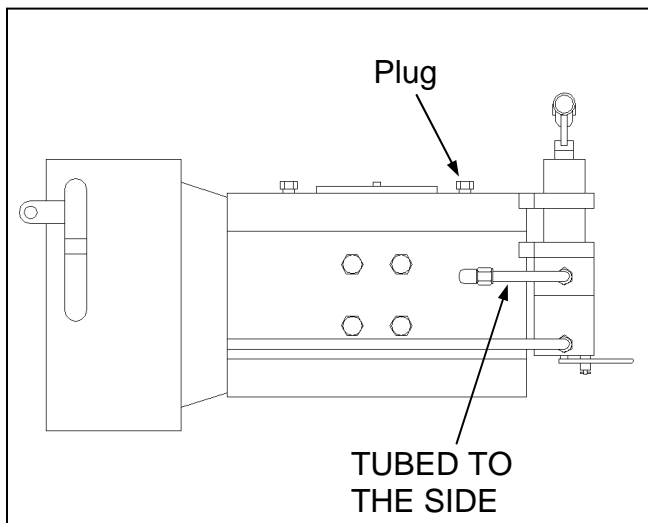

Figure 1: Old Hand Pump Assembly

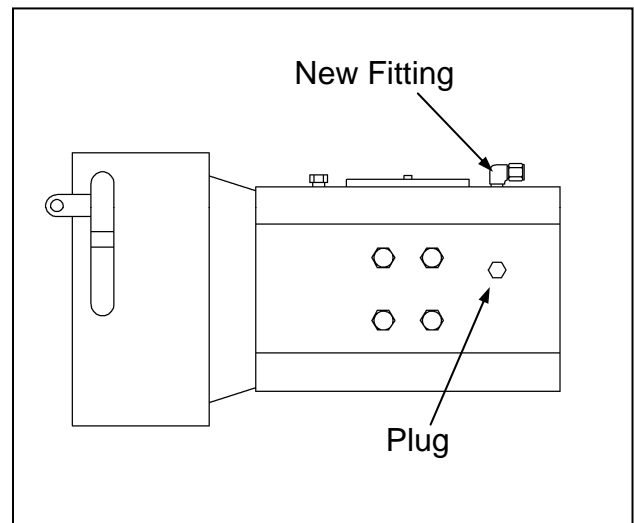

Figure 2: Old Hand Pump Removed

MOD H30: Installation Procedure

HP/HYD/INST

05-04-11

5. Install the new universal hand pump mounting bracket using the mounting holes for the old hand pump. (See Figure 3)
6. Install the new hand pump.

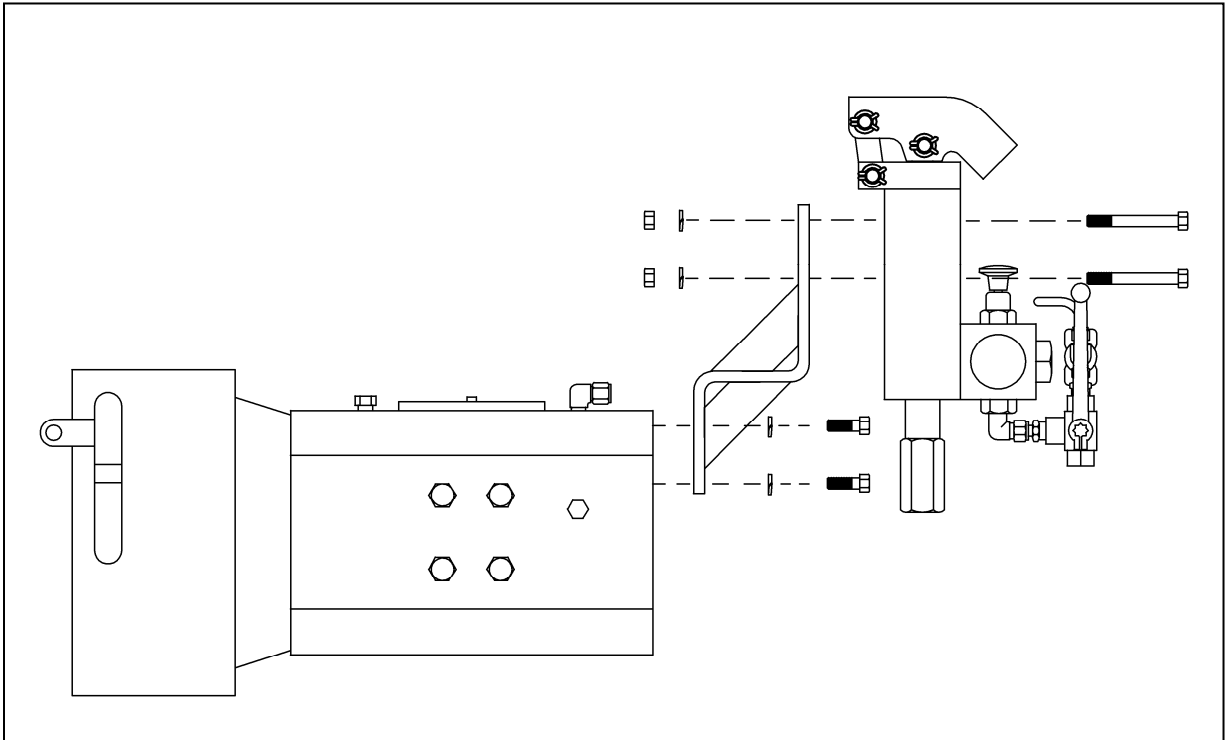

Figure 3: Installation of new hand pump

7. Install new Swagelok® fittings in the hand pump, isolation valves, actuator upper head and poppet block control. Apply an appropriate pipe sealant to the threads.
8. Run tubing from the bottom of the isolation valves to the cylinder ports in the back of the poppet block control. (See Figure 4) Right isolation valve is CLOSE and the left isolation valve is OPEN (as you are facing the new hand pump).
9. Run tubing from the discharge ports located on top of the hand pump valve body. (See Figure 4) The right side of the pump runs to the port on the right in the upper head of the actuator. The left side of the pump runs to the port on the left in the upper head of the actuator. Make sure you are using the ports in the upper head closest to hand pump, not the ones on the far side. (See Figure 2)
10. Run tubing from the open port in the tee to the reservoir tank. Tee is shown above the right hand isolation valve in Figure 4. It may be above either isolation valve.
11. Fill the reservoir tank to the proper fluid level.

MOD H30: Installation Procedure

HP/HYD/INST

05-04-11

12. To manually stroke the actuator, either open or closed, place the isolation valve handles in the horizontal position (see Figure 4) and select the appropriate knob on the selector valve located on the hand pump. This knob is selected by pressing inward toward the pump center.

Note: The pump has a label designating which knob is open and close.

13. Using the supplied pump handle, raise the hand pump clevis, which will draw hydraulic fluid into the pump. Pull the handle downward to discharge hydraulic fluid into the actuator. Repeat this process until the actuator reaches its end of stroke.

14. When the pumping cycle is completed, depress the manual relief valve located on the top of the selector valve on the pump and pull the pump ram back into the pump body.

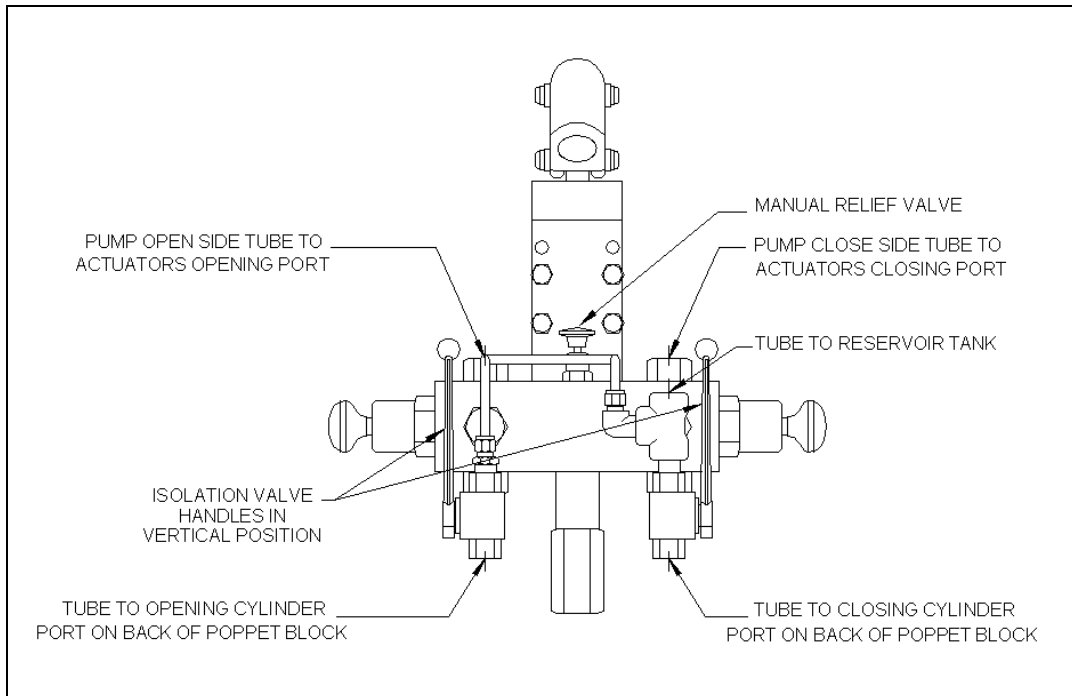

Figure 4: Hand Pump Piping

15. Return the isolation valve handles to the vertical position.

16. The automatic features of the control circuit can now be used.

MOD H30: Installation Procedure

HP/HYD/INST

05-04-11

17. Open the return oil and power oil valves from the central hydraulic power unit.
18. Check to see the isolation valve handles are in the vertical position, as shown in Figure 4. Use the manual handles on the poppet block control to open and close the actuator working the air out of the system.
19. The automatic features of the control circuit can now be used
20. The hand pump will automatically shift to neutral when either the OPEN cylinder line or the CLOSE cylinder line is pressurized during an automatic cycle of the control circuit.
21. Carefully check over system to insure there is no leakage. Repair any leaks found.
22. Leave the actuator in the desired position.

If any further information is required, please feel free to contact:

Emerson Process Management
Valve Automation Inc.
2500 Park Avenue West
Mansfield, Ohio 44906

Phone: (419) 529-4311

Fax (419) 529-3688

Please visit our website for up to date product data. www.shafervalve.com

All Rights Reserved

The contents of this publication are presented for informational purpose only, and while every effort has been made to ensure their accuracy, they are not to be construed as warranties or guarantees, express or implied, regarding the products or services described herein or their use or applicability. We reserve the right to modify or improve the designs or specifications of such products at any time with out notice.

Trademarks owned by other companies that are referred to in our product literature include: Swagelok®