

**Mod H20: Replacement Procedure**

**ActCont Manual Hyd**

05-04-11

## **Actuator Control – Manual**

Replacement Procedure on a Rotary Vane Actuator with  
Central Hydraulic System

## Mod H20: Replacement Procedure

ActCont Manual Hyd

05-04-11

The purpose of this procedure is to guide the replacement of an Actuator Control with standard features.

This procedure is to be used in conjunction with the following Maintenance and Service Manuals.

Shafer Poppet Block Control Maintenance and Service Manual	Bulletin PBC-01102001
Shafer Hand Pump Maintenance and Service Manual	Bulletin MHP-01102001

- WARNING:** 1. Close the valve in the power oil line from the central hydraulic system.
-  2. Bleed off the pressure in the control by operating the manual handles on the poppet block control until the gauge in the poppet block reads 0 PSI.
3. Close the valve in the return line.

### Remove the Old Control Box and Hand Pump

1. Remove the piping to the power port and exhaust port of the old control block.
2. Remove tubing from the lower fittings in the hand pump going to the control.
3. Remove tubing from hand pump to actuator.

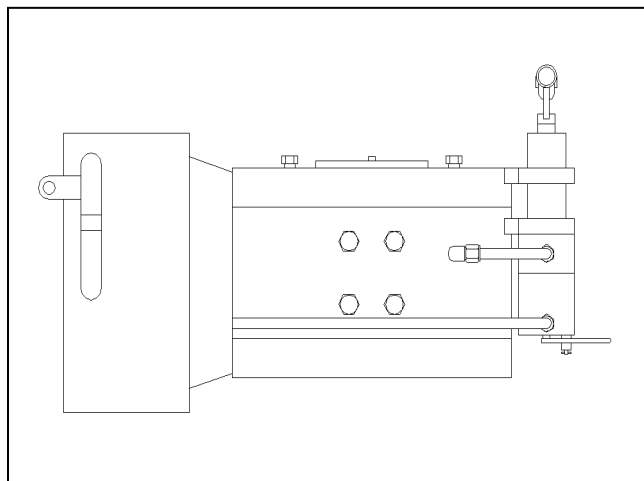

**Figure 1: Typical Original Assembly**

4. This should complete the pipe/tube connections and free the old control box and hand pump for removal. Remove the control box and hand pump. Set the old parts aside for reference.

## Mod H20: Replacement Procedure

ActCont Manual Hyd

05-04-11

---

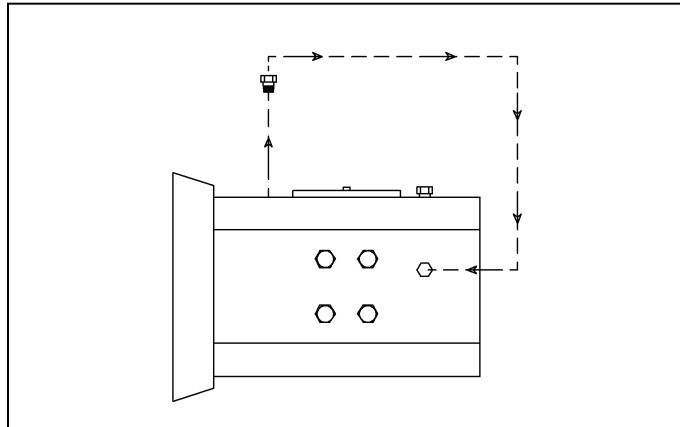

**Figure 2: Old Components Removed**

5. Remove the fittings in the side of the actuator that were tubed to the OPEN and CLOSE lines from the old hand pump. Also remove the plugs in the upper head on the control side. Clean the threads of the plugs, apply an appropriate pipe sealant and plug the side ports. (See Figure 2)

## Install the New Control Box

The new control box mounts to the same holes in the bracket on the actuator as the old one using 4" long standoffs. Look the new hardware over to enable identification of the parts.

1. Using 4 of the 8 mounting bolts and lock washers, install the four standoffs to the mounting bracket. Do not tighten the bolts. (See Figure 3)
2. With the other four mounting bolts and lock washers install the new control box using the 9.5" x 11.25" hole pattern in the control box back plate. Leave the bolts finger tight.

## Mod H20: Replacement Procedure

ActCont Manual Hyd

05-04-11

3. Tighten the mounting bolts in the bracket and then tighten the bolts in the back plate.

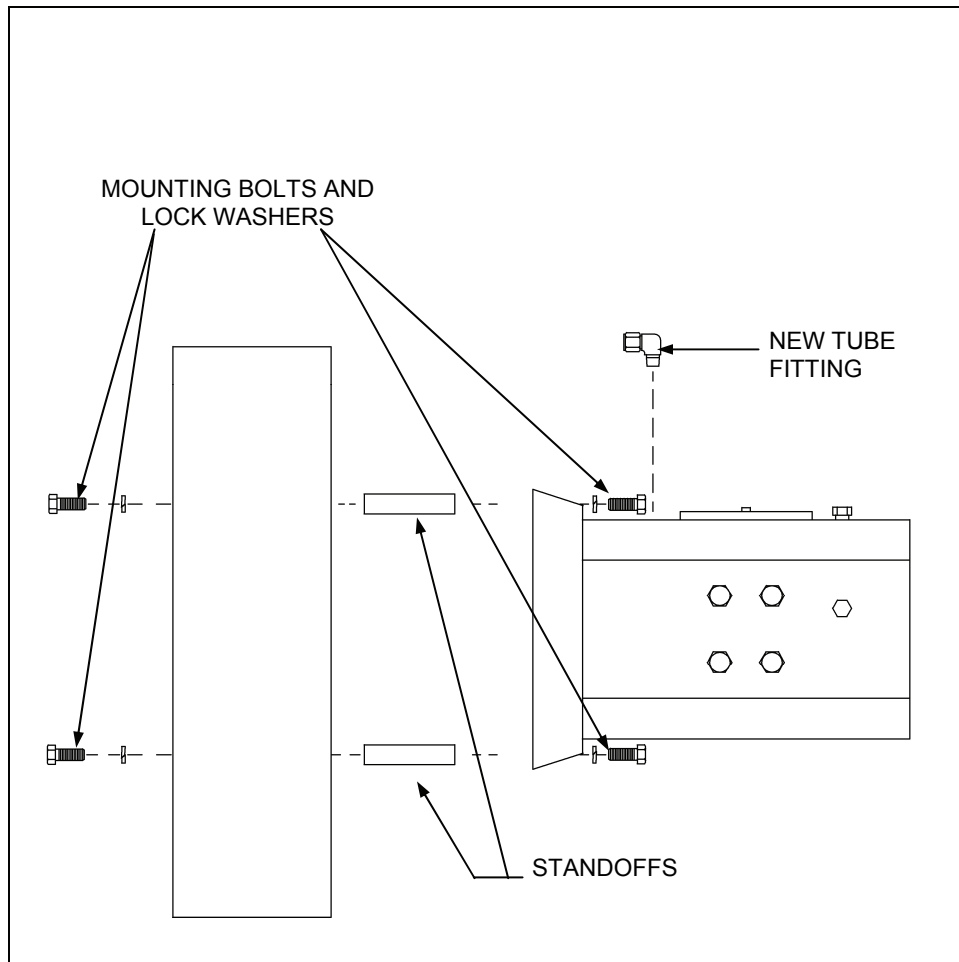

**Figure 3: Installing New Control**

4. Install new Swagelok<sup>®</sup> fittings in the hand pump (or optional speed control valves), tee fitting above the isolation valves and the actuator upper head. Apply an appropriate pipe sealant to the threads. (See Figures 3 and 4)
5. Run tubing from the discharge ports located on top of the hand pump valve body or optional speed control valves. (See Figure 4) The right side of the pump runs to the port on the right in the upper head of the actuator. The left side of the pump runs to the port on the left in the upper head of the actuator. Make sure you are using the ports in the upper head closest to hand pump, not the ones on the far side. (See Figure 2)
6. Run tubing from the open port in the tee to the reservoir tank. Tee is shown above the left hand isolation valve in Figure 4. It may be above either isolation valve.

## Mod H20: Replacement Procedure

ActCont Manual Hyd

05-04-11

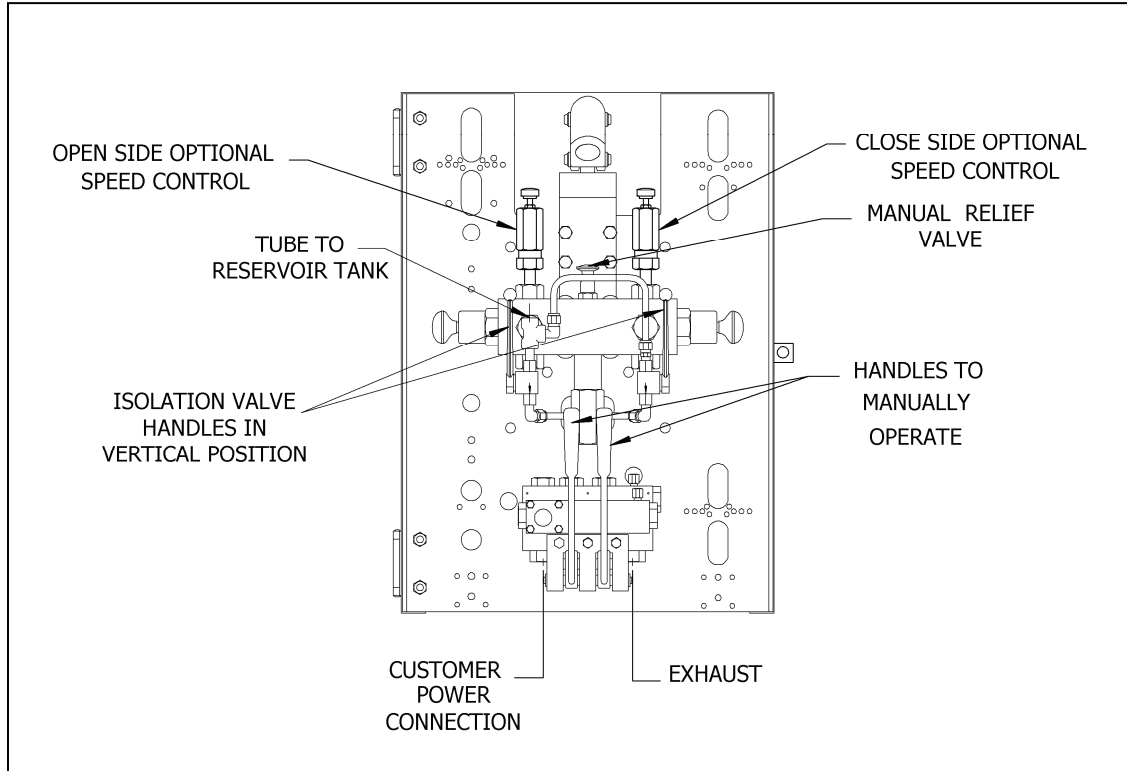

**Figure 4: View of the Control from the Front**

7. Fill the reservoir tank to the proper fluid level.
8. Use the hand pump to close or open the actuator to purge the actuator and hydraulic lines. To manually stroke the actuator, either open or close, place the isolation valve handles in the horizontal position (see Figure 4) and select the appropriate knob on the selector valve located on the hand pump. This knob is selected by pressing inward toward the pump center.  
**Note:** The pump has a label designating which knob is open and close.
9. Using the supplied pump handle, raise the hand pump clevis, which will draw hydraulic fluid into the pump. Pull the handle downward to discharge hydraulic fluid into the actuator. Repeat this process until the actuator reaches its end of stroke.
10. When the pumping cycle is completed, depress the manual relief valve located on the top of the selector valve on the pump and pull the pump ram back into the pump body.
11. Return the isolation valve handles to the vertical position.
12. The automatic features of the control circuit can now be used.

## Mod 6: Replacement Procedure

ActCont Manual Hyd

05-04-11

---

13. The hand pump will automatically shift to neutral when either the OPEN cylinder line or the CLOSE cylinder line is pressurized during an automatic cycle of the control circuit.
14. Turn the power oil from the central hydraulic power unit on.
15. Check to see the isolation valve handles are in the vertical position, as shown in Figure 4. Use the manual handles on the poppet block control to open and close the actuator.
16. Carefully check over system to insure there is no leakage. Repair any leaks found.
17. Leave the actuator in the desired position.

If any further information is required, please feel free to contact:

Emerson Process Management  
Valve Automation Inc.  
2500 Park Avenue West  
Mansfield, Ohio 44906

Phone: (419) 529-4311

Fax (419) 529-3688

Please visit our website for up to date product data. [www.shafervalve.com](http://www.shafervalve.com)

The contents of this publication are presented for informational purpose only, and while every effort has been made to ensure their accuracy, they are not to be construed as warranties or guarantees, express or implied, regarding the products or services described herein or their use or applicability. We reserve the right to modify or improve the designs or specifications of such products at any time with out notice.

Trademarks owned by other companies that are referred to in our product literature include: Swagelok®