

# L - Series

## Linear Valve Actuators

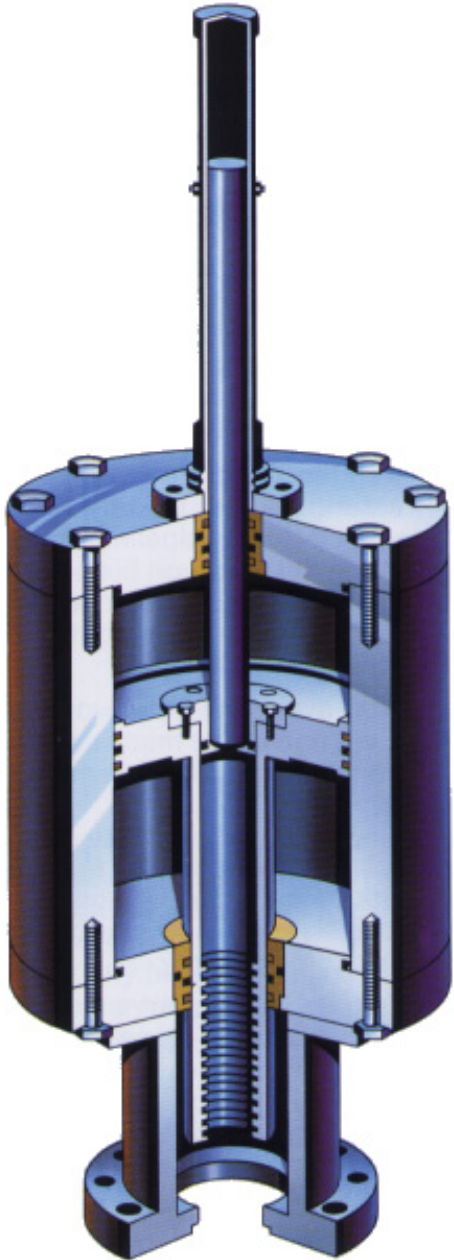

### THRUST RATINGS AND DIMENSIONAL DATA

#### U. S. CUSTOMARY UNITS

Dimensions : Inches (in)

Thrust: Pounds (lbs)

Pressure: Pounds Per Square Inch (psi)

Weight: Pounds (lbs)

Volume: Cubic Inches (in<sup>3</sup>)

# Dimensional Data

## ACTUATOR WITH GAS/HYDRAULIC TANKS FOR GAS OVER OIL APPLICATIONS

All dimensions shown in inches.

Valve Size	6"	8"	10"	12"	14"	16"	18"	20"	22"	24"	26"	30"	36"	42"	48"
<b>A</b>	31 1/8	32 7/8	34 1/8	39 1/2	39 1/2	39 1/2	58 3/8	58 3/8	58 3/8	58 3/8	58 3/8	58 3/8	66 1/2	83 3/4	83 3/4
<b>B</b>	12 5/8	13 5/8	13 5/8	17 5/8	17 5/8	17 5/8	26	26	26	26 1/8	26 1/8	25 5/8	29 1/4	36 7/8	36 7/8
<b>C</b>	3 1/4	3 1/4	3 1/4	3 1/4	3 1/4	3 1/4	6 5/8	6 5/8	6 5/8	6 5/8	6 5/8	6 5/8	6 5/8	6 5/8	6 5/8
<b>D</b>	6 7/8	6 7/8	6 7/8	6 7/8	6 7/8	6 7/8	3 3/4	3 3/4	3 3/4	3 3/4	3 3/4	3 3/4	3 3/4	3 3/4	3 3/4
<b>E</b>	36 1/4	36 1/2	36 1/2	36 5/8	36 5/8	36 5/8	40 7/8	40 7/8	40 7/8	40 7/8	41	40	43	43 1/4	43 1/4
<b>F</b>	13 7/8	14	14	15 3/4	15 3/4	15 3/4	17 7/8	17 7/8	17 7/8	17 7/8	18	17 3/4	19 3/4	17	21 3/4
<b>G</b>	24 1/4	24 3/8	24 1/2	25 1/4	25 1/4	25 1/4	29 7/8	29 7/8	29 7/8	29 7/8	29 7/8	29 7/8	31 3/4	30 1/8	33 1/2
<b>H</b>	48 1/4	48 1/2	48 1/2	40	40	40	55 5/8	55 5/8	55 5/8	55 5/8	55 3/4	55 3/4	61	65 1/4	69 5/8
<b>J</b>	7 5/8	5 3/4	1 1/2	12	16	12	18	18	18	24	24	24	30	38	44 1/2
<b>K</b>	36 1/8	36 3/4	38 1/4	59	62 5/8	64	77	88 3/4	97	101 1/4	116 3/4	121	139	147 3/8	178
<b>L</b>	28 3/8	28 3/4	25 5/8	42 1/4	45	44 1/4	58 7/8	63 1/4	70 1/2	72 3/4	88 1/4	92 1/2	96 3/4	101	105 1/4
<b>M</b>	12 5/8	12 5/8	12 5/8	12 5/8	12 5/8	12 5/8	12 5/8	12 5/8	12 5/8	12 5/8	12 5/8	12 5/8	12 5/8	12 5/8	12 5/8
<b>R</b>	27	27	27	27	27	27	28 1/4	28 1/4	28 1/4	28 1/4	28 1/4	28 1/4	28 1/4	28 1/4	28 1/4

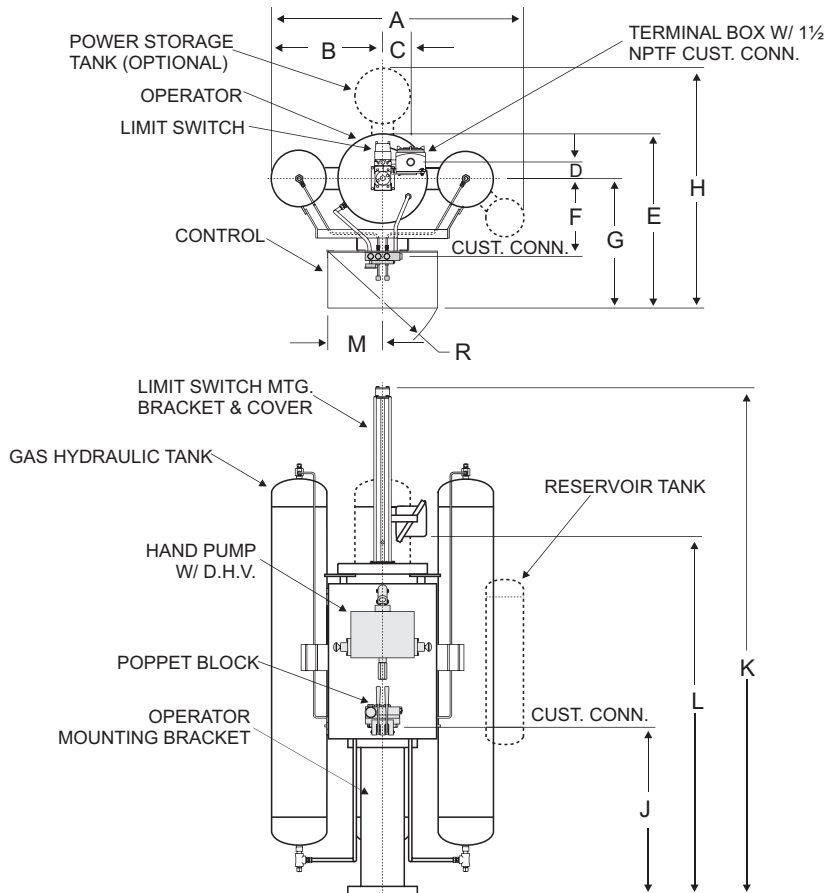

# Dimensional Data

## HYDRAULIC ACTUATOR

All dimensions shown in inches.

Valve Size	6"	8"	10"	12"	14"	16"	18"	20"	22"	24"	26"	30"	36"	42"	48"
A	27	27	27	27	27	27	27	27	27	28	28	28	28	28	30
B	9 5/8	9 5/8	9 5/8	9 5/8	9 5/8	9 5/8	14 1/8	14 1/8	14 1/8	14 1/8	14 1/8	14 1/8	14 1/8	14 1/8	14 1/8
C	3 1/4	3 1/4	3 1/4	3 1/4	3 1/4	3 1/4	6 5/8	6 5/8	6 5/8	6 5/8	6 5/8	6 5/8	6 5/8	6 5/8	6 5/8
D	6 7/8	6 7/8	6 7/8	6 7/8	6 7/8	6 7/8	3 3/4	3 3/4	3 3/4	3 3/4	3 3/4	3 3/4	3 3/4	3 3/4	3 3/4
F	17 3/4	18 5/8	19 1/4	19 1/4	20 1/8	20 1/8	21 1/8	21 1/8	21 1/8	19 1/2	21	23	30 1/8	31 5/8	32 3/4
G	22 1/2	24	24	24	24 7/8	24 7/8	25 7/8	25 7/8	25 7/8	26 1/2	28	30	37 5/8	38 5/8	40 3/4
H	36 1/4	36 1/2	36 1/2	36 1/2	37 1/2	37 1/2	38 1/2	38 1/2	38 1/2	37	39	40 1/2	49 3/4	51 3/4	56
J	12	14	16	18	20	22	24	26	28	30	34	36	44	50	56
K	34 7/8	40 7/8	47 1/8	53 1/8	59 1/8	65 1/8	71 1/8	77 1/8	83 1/8	88 5/8	94 5/8	100 5/8	124 7/8	140 7/8	156 7/8
L	28 3/8	28 3/4	40 5/8	36 3/8	41 1/2	45 3/8	53	59	65	70 1/2	76 1/2	82 1/2	106 3/4	122 3/4	138 3/4
R	23 7/8	23 7/8	23 7/8	23 7/8	23 7/8	23 7/8	33 1/2	33 1/2	33 1/2	33 1/2	33 1/2	33 1/2	33 1/2	33 1/2	33 1/2

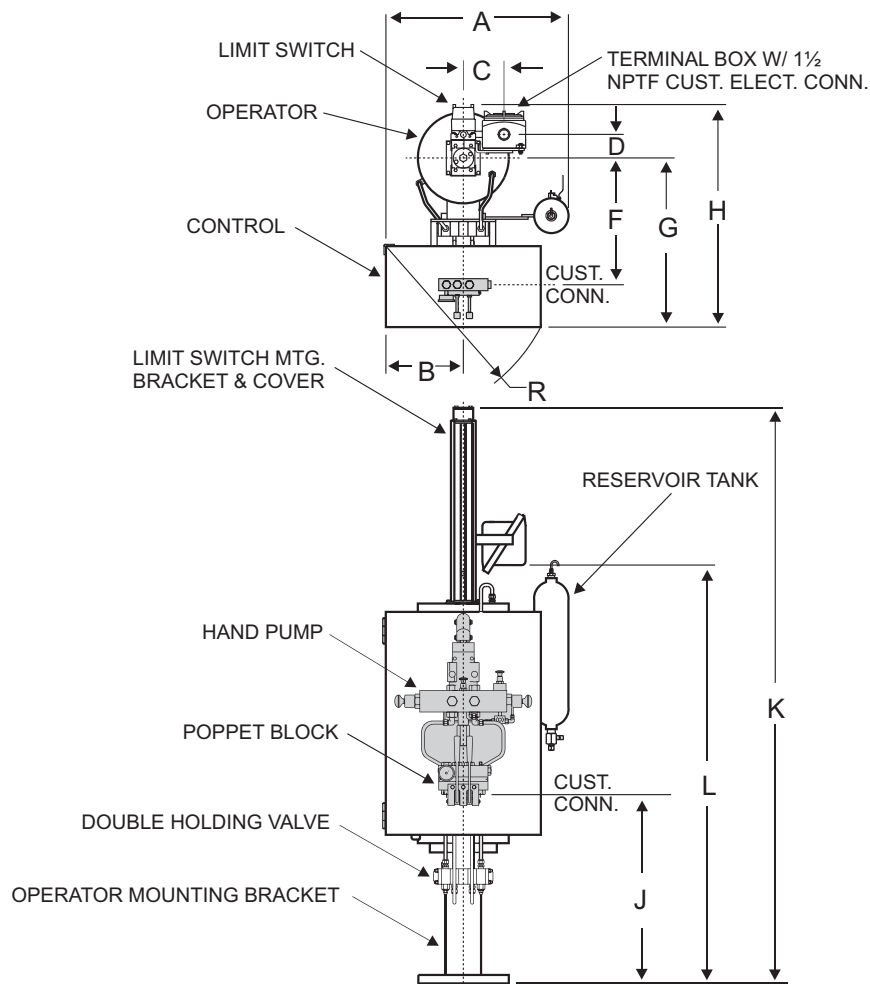

# Thrust Table

All thrusts shown in pounds. All diameters shown in inches.

Maximum Acceptable Valve Stem Dia.	Piston Dia. (In)	* Downward Closing Thrust Factor (In <sup>2</sup> )	* Upward Opening Thrust Factor (In <sup>2</sup> )	Maximum Allowable Thrust (lbs)	Typical Valve Size
1 3/8	4	9.975	9.975	17,800	4" - 6"
2	4	9.975	8.480	24,480	4" - 6"
2	6	24.11	22.61	40,500	8" - 10"
2 3/4	6	24.11	20.10	47,860	8" - 10"
2 1/2	8	43.90	40.82	66,260	10" - 14"
3 1/4	8	43.90	37.77	77,300	10" - 14"
2 3/4	10	69.35	65.34	83,380	16" - 18"
3 3/4	10	69.35	60.74	112,680	16" - 18"
3	12	100.45	95.43	102,460	20" - 22"
4 1/4	12	100.45	89.02	153,900	20" - 22"
3 1/2	14 7/8	155.06	147.74	146,500	24" - 26"
5 3/4	14 7/8	155.06	133.03	252,060	24" - 26"
5	16 1/2	190.57	174.76	213,780	28" - 30"
5 3/4	16 1/2	190.57	169.07	283,480	28" - 30"
5	18 3/4	246.64	230.83	213,780	32" - 36"
6 1/4	18 3/4	246.64	220.89	312,940	32" - 36"
5	20 1/4	287.98	272.18	213,780	36" - 40"
6 1/4	20 1/4	287.98	262.24	312,940	36" - 40"
5 3/4	22	340.25	318.74	283,480	40" - 42"
6 1/4	22	340.25	314.50	312,940	40" - 42"

Shafer L-Series linear actuators are custom engineered to match the specific application requirements of stroke length, thrust, and power pressure. Due to the vast number of combinations offered by valve manufacturers, little standardization is allowed. Various diameter cylinders may be utilized as thrust requirements and power supply pressures vary. The Thrust Table gives only a representative sample of our total capabilities. Please contact our factory for specific actuator sizing requirements.

Normal design working pressure is 1,480 psi with a test pressure of 2,220 psi, however, higher pressures may be specified.

\* To determine the actuator thrust output, multiply the thrust factor (In<sup>2</sup>) times the power supply pressure (psi).

Thrust Output = Thrust Factor (In<sup>2</sup>) x Power Pressure (psi)

[www.EmersonProcess.com/Shafer](http://www.EmersonProcess.com/Shafer)

#### Shafer

2500 Park Ave. West, Mansfield, OH 44906  
Phone (419) 529-4311, FAX (419) 529-3688

[info.Mansfield@EmersonProcess.com](mailto:info.Mansfield@EmersonProcess.com)

L-TRDD-D-11097

**Shafer™**



**EMERSON™**  
Process Management