

L - Series

Linear Valve Actuators

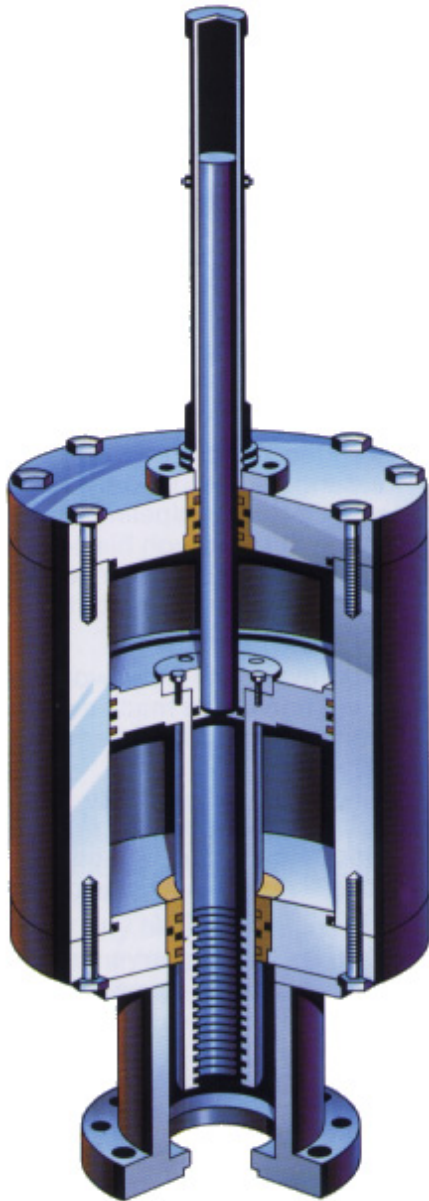

THRUST RATINGS AND DIMENSIONAL DATA

METRIC UNITS

Dimensions : Centimeters (cm)
Thrust: Kilograms (kg)
Pressure: Bar
Weight: Kilograms (kg)
Volume: Cubic Centimeters (cm³)

Dimensional Data

ACTUATOR WITH GAS/HYDRAULIC TANKS FOR GAS OVER OIL APPLICATIONS

Valve size in inches. All other dimensions shown in centimeters.

Valve Size	6"	8"	10"	12"	14"	16"	18"	20"	22"	24"	26"	30"	36"	42"	48"
A	79.06	83.50	86.68	100.33	100.33	100.33	148.27	148.27	148.27	148.27	148.27	148.27	168.91	212.73	212.73
B	32.07	34.61	34.61	44.77	44.77	44.77	66.04	66.04	66.04	66.36	66.36	65.09	74.30	93.66	93.66
C	8.26	8.26	8.26	8.26	8.26	8.26	16.83	16.83	16.83	16.83	16.83	16.83	16.83	16.83	16.83
D	17.46	17.46	17.46	17.46	17.46	17.46	9.53	9.53	9.53	9.53	9.53	9.53	9.53	9.53	9.53
E	92.08	92.71	92.71	93.03	93.03	93.03	103.82	103.82	103.82	103.82	104.14	101.60	109.22	109.86	109.86
F	35.24	35.56	35.56	40.01	40.01	40.01	45.40	45.40	45.40	45.40	45.72	45.09	50.17	43.18	55.25
G	61.60	61.91	62.23	64.14	64.14	64.14	75.88	75.88	75.88	75.88	75.88	75.88	80.65	76.52	85.09
H	122.56	123.19	123.19	101.60	101.60	101.60	141.29	141.29	141.29	141.29	141.61	141.61	154.94	165.74	176.85
J	19.37	14.61	3.81	30.48	40.64	30.48	45.72	45.72	45.72	60.96	60.96	60.96	76.20	96.52	113.03
K	91.76	93.35	97.16	149.86	159.07	162.56	195.58	225.43	246.38	257.18	296.55	307.34	353.06	374.33	452.12
L	72.07	73.03	65.09	107.32	114.30	112.40	149.54	160.66	179.07	184.79	224.16	234.95	245.75	256.54	267.34
M	32.07	32.07	32.07	32.07	32.07	32.07	32.07	32.07	32.07	32.07	32.07	32.07	32.07	32.07	32.07
R	68.58	68.58	68.58	68.58	68.58	68.58	71.76	71.76	71.76	71.76	71.76	71.76	71.76	71.76	71.76

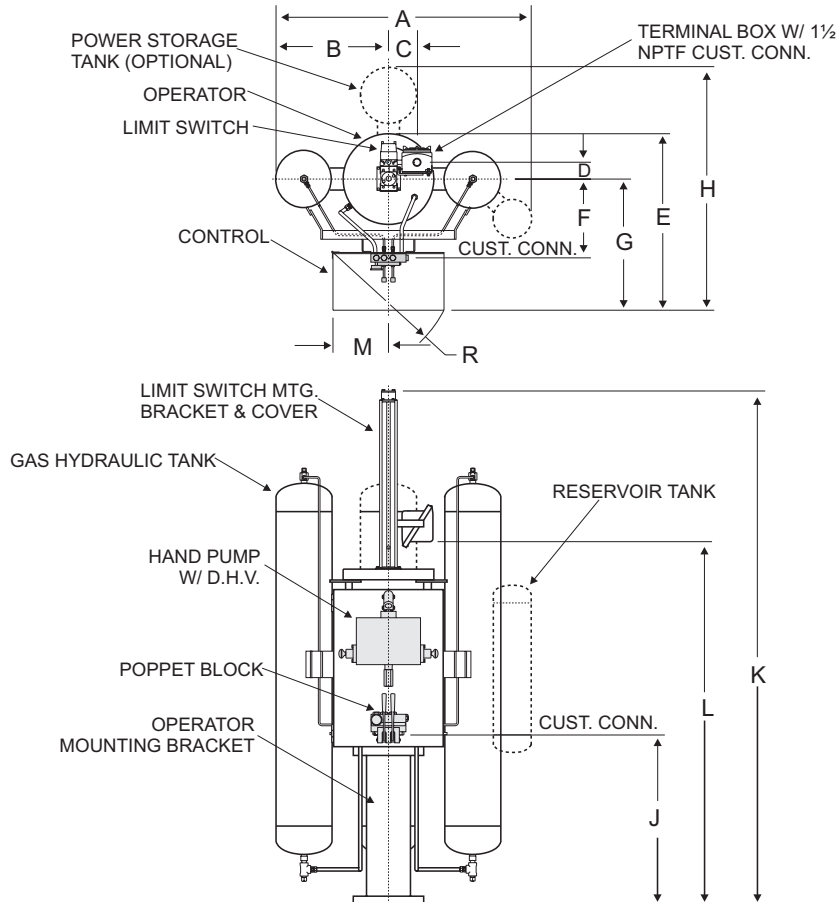

Dimensional Data

HYDRAULIC ACTUATOR

Valve size in inches. All other dimensions shown in centimeters.

Valve Size	6"	8"	10"	12"	14"	16"	18"	20"	22"	24"	26"	30"	36"	42"	48"
A	68.58	68.58	68.58	68.58	68.58	68.58	68.58	68.58	68.58	71.12	71.12	71.12	71.12	71.12	76.20
B	24.45	23.81	23.81	23.81	23.81	23.81	37.78	37.78	37.78	37.78	37.78	37.78	37.78	37.78	35.88
C	8.26	8.26	8.26	8.26	8.26	8.26	16.19	16.19	16.19	16.19	16.19	16.83	16.19	16.19	16.19
D	17.46	17.46	17.46	17.46	17.46	17.46	9.53	9.53	9.53	9.53	9.53	9.53	9.53	9.53	9.53
F	45.09	46.67	48.90	48.90	53.02	53.02	55.56	55.56	55.56	49.53	53.34	58.42	78.42	79.69	83.19
G	57.15	60.96	60.96	60.96	63.18	63.18	65.72	65.72	65.72	67.31	71.12	76.20	94.93	97.47	103.51
H	92.08	92.71	92.71	92.71	95.25	95.25	97.79	97.79	97.79	93.98	99.06	102.87	126.37	131.45	142.24
J	30.48	35.56	40.64	45.72	50.80	55.88	60.96	66.04	71.12	76.20	86.36	91.44	111.76	127.00	142.24
K	88.58	103.82	121.60	136.84	152.08	167.32	182.56	197.80	213.04	224.47	239.71	254.95	317.18	357.82	398.46
L	72.07	73.03	102.55	92.39	105.41	115.25	134.62	149.86	165.10	179.07	194.31	209.55	271.15	311.79	352.43
R	60.64	60.64	60.64	60.64	60.64	60.64	85.09	85.09	85.09	85.09	85.09	85.09	85.09	85.09	85.09

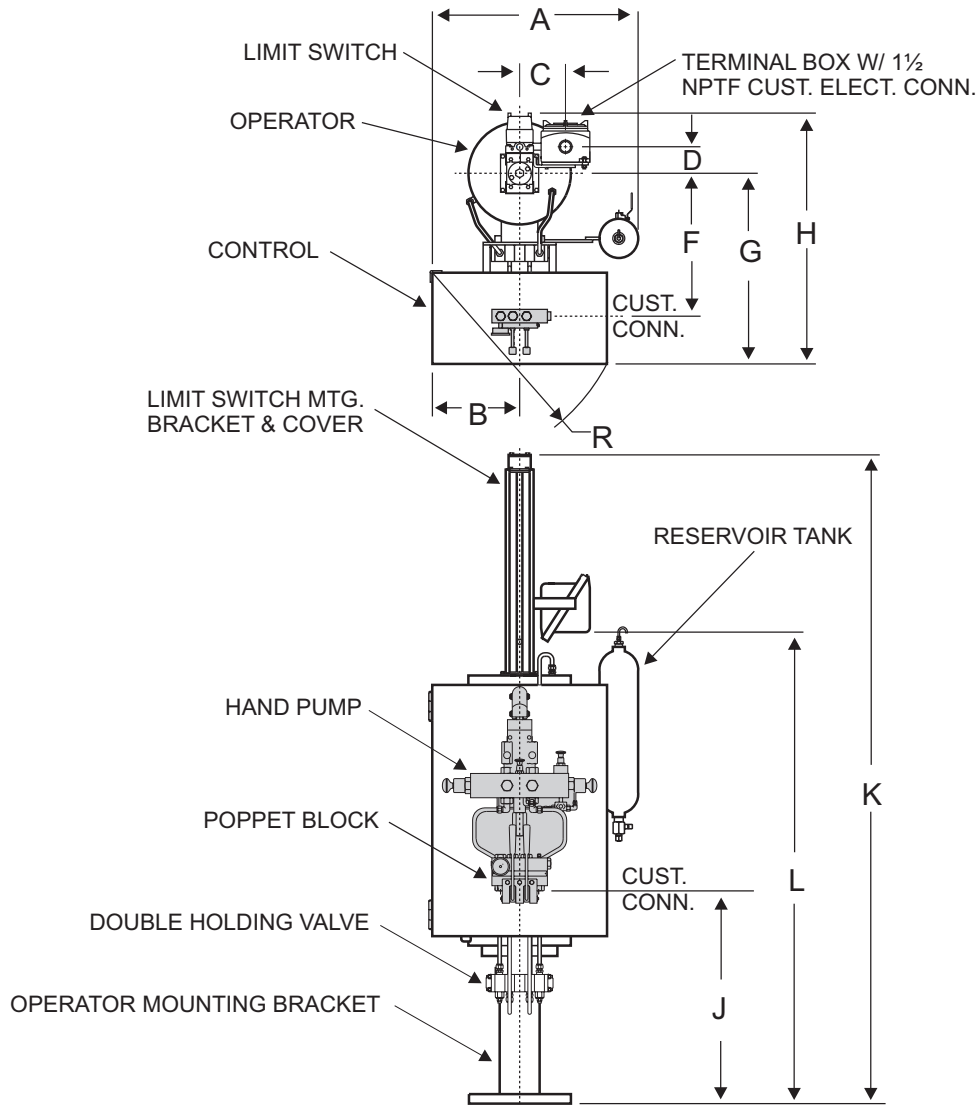

Thrust Table

All thrusts shown in kilograms, All diameters shown in centimeters.

Maximum Acceptable Valve Stem. Dia.	Piston Dia. (cm)	* Downward Closing Thrust Factor (cm ²)	* Upward Opening Thrust Factor (cm ²)	Maximum Allowable Thrust (kg)	Typical Valve Size
3.49	10.16	64.36	64.36	8,073.9	4" - 6"
5.08	10.16	64.36	54.71	11,103.9	4" - 6"
5.08	15.24	155.56	145.88	18,370.5	8" - 10"
6.99	15.24	155.56	129.69	21,708.9	8" - 10"
6.35	20.32	283.24	263.37	30,055.0	10" - 14"
8.26	20.32	283.24	243.69	35,062.7	10" - 14"
6.99	25.40	447.45	421.57	37,820.5	16" - 18"
9.53	25.40	447.45	391.89	51,110.7	16" - 18"
7.62	30.48	648.10	615.71	46,475.0	20" - 22"
10.80	30.48	648.10	574.36	69,807.8	20" - 22"
8.89	37.78	1000.45	953.22	66,451.2	24" - 26"
14.61	37.78	1000.45	858.31	114,332.4	24" - 26"
12.70	41.91	1229.56	1127.55	96,968.9	28" - 30"
14.61	41.91	1229.56	1090.84	128,584.3	28" - 30"
12.70	47.63	1591.32	1489.32	96,968.9	32" - 36"
15.88	47.63	1591.32	1425.18	14,1947.1	32" - 36"
12.70	51.44	1858.05	1756.11	96,968.9	36" - 40"
15.88	51.44	1858.05	1691.97	141,947.1	36" - 40"
14.61	55.88	2195.29	2056.51	128,584.3	40" - 42"
15.88	55.88	2195.29	2029.15	14,1947.1	40" - 42"

Shafer L-Series linear actuators are custom engineered to match the specific application requirements of stroke length, thrust, and power pressure. Due to the vast number of combinations offered by valve manufacturers, little standardization is allowed. Various diameter cylinders may be utilized as thrust requirements and power supply pressures vary. The Thrust Table gives only a representative sample of our total capabilities. Please contact our factory for specific actuator sizing requirements.

Normal design working pressure is 671.3 bar with a test pressure of 1,007.0 bar, however, higher pressures may be specified.

* To determine the actuator thrust output, multiply the thrust factor (cm²) times the power supply pressure (kg/cm²).

Thrust Output = Thrust Factor (cm²) x Power Pressure (kg/cm²)

www.EmersonProcess.com/Shافر

Shafer

2500 Park Ave. West, Mansfield, OH 44906
 Phone (419) 529-4311, FAX (419) 529-3688
info.Mansfield@EmersonProcess.com

L-TRDD-L-11097

Shafer™



EMERSON™
 Process Management