

Shafer™

Manual Hydraulic Hand Pump

The all new balanced piston pump design provides an efficient hand pumping system to close or open conventional pipeline valves and acts as a standby manually operated system. The all new Shafer Pump has a balanced ram design to eliminate accidental or uncontrolled action of the pump ram in the event that pressurized gas or fluid should enter the pump cavity under the piston. The Shafer pump also provides an improved hand pump system which eliminates cavitation, or sucking air, by forcing fluid into pump suction chamber during the downward pressure stroke, therefore, providing a full cavity of oil for the next pressure stroke.

This anti-cavitation feature allows the pump to be stroked at any speed without drawing a vacuum into the pumping chamber. A further provision is the automatic self-neutralizing feature which functions in the event that the valve selector is left in either the open or close position after hand pumping.

This self-neutralizing feature pilots the valve controls into neutral or automatic when power oil or gas is forced into the hand pump system. To eliminate leaving the pump ram in the up position exposed to atmospheric conditions, the pump is equipped with a manual operated pressure relief valve for relieving pressure after the pumping cycle is complete.

This relief valve feature allows the ram to be pulled back down into the pump head, thus protecting it against corrosive or detrimental atmospheric conditions.

Other improvement features include:

1. Fully hard-anodized aluminum body construction for salt atmosphere protection.
2. Stainless steel port connections for fittings.
3. Stainless steel pins, bolts and instruction plate.
4. Improved fulcrum-lever design for higher pressure pumping.
5. Available in 4 and 12 cubic inch /stroke positive displacement models.

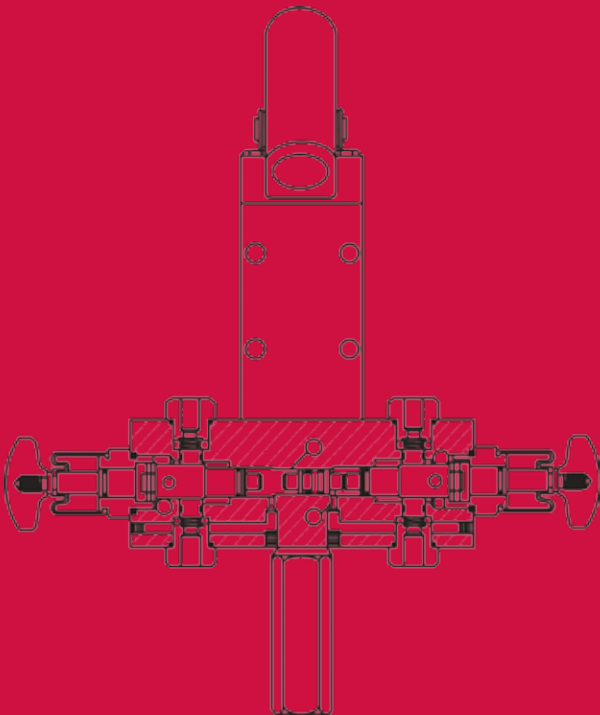

PORTABLE HYDRAULIC HAND PUMP

The manual hydraulic hand pump is mounted as an integral component of most Shafer valve operating systems. However, in applications where space is limited or economics and design dictate the hand pump may be deleted from the operator package and in its place are fitted quick disconnect couplings. The hand pump with reservoir is then mounted onto a two wheel cart with flexible hydraulic hoses and quick disconnect couplings which provides portable manual operation to any number of valve operators.

When the hand pump is required, it is simply wheeled to the valve operator and the flexible hoses are coupled to the quick disconnect couplings on the operator. The open or close selector button is pushed and the pump operated in the normal manner to open or close the valve operator. Once the valve actuator is in the desired position, the hoses are disconnected and the portable pump returned to its storage location.

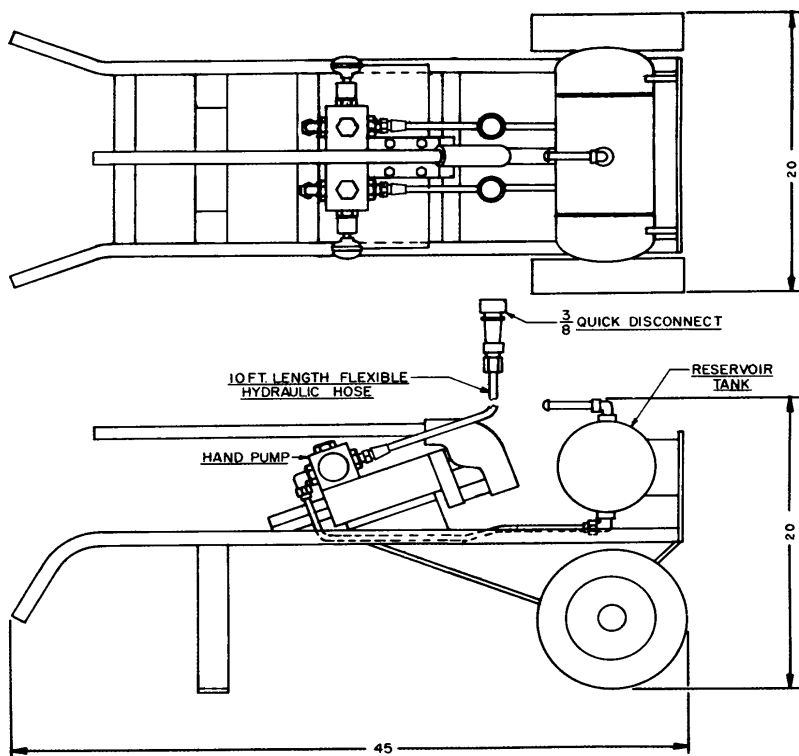

www.EmersonProcess.com/Shaffer

Emerson Process Management Valve Automation, Inc.
2500 Park Ave. West
Mansfield, OH 44906
Phone (419) 529-4311
FAX (419) 529-3688
info.Mansfield@EmersonProcess.com

Shafer[™]

EMERSON[™]
Process Management