

**Data sheet**

Sheet No.: D39, Rev. A

Date: Sept. 2005

**Hytork XL**

# Envelope Dimensions and Torque Data

## XL4581 Double acting and Spring Return actuator

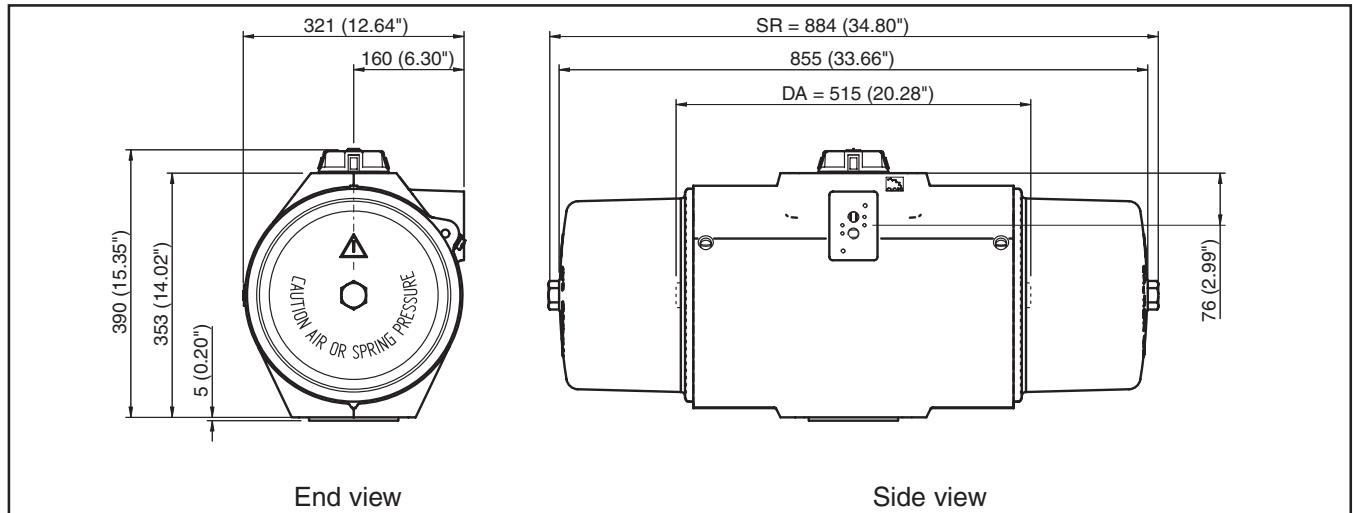

Torque in Nm, Pressure in bar(g)														
Double Acting Torques		1763		2351		2939		3232		3526		4114		
Spring Rating	Torque From Springs		3.0 bar(g)		4.0 bar(g)		5.0 bar(g)		5.5 bar(g)		6.0 bar(g)		7.0 bar(g)	
	Start	End	Start	End	Start	End	Start	End	Start	End	Start	End	Start	End
S40	1017	610	1153	747	1741	1334	2329	1922	2623	2216	2916	2510	3504	3097
S50	1271	762	1001	492	1588	1080	2176	1668	2470	1962	2764	2256	3352	2843
S60	1525	915	848	238	1436	826	2024	1414	2318	1708	2611	2001	3199	2589
S70	1779	1067	-	-	1284	572	1871	1160	2165	1453	2459	1747	3047	2335
S80	2033	1220	-	-	1131	318	1719	905	2013	1199	2306	1493	2894	2081
S90	2287	1372	-	-	-	-	1566	651	1860	945	2154	1239	2742	1827
S1C	2541	1525	-	-	-	-	1414	397	1708	691	2001	985	2589	1573

Torque in inch-pounds, Pressure in PSI														
Double Acting Torques		14250		17813		21375		28500		32063		35625		
Spring Rating	Torque From Springs		40 PSI		50 PSI		60 PSI		80 PSI		90 PSI		100 PSI	
	Start	End	Start	End	Start	End	Start	End	Start	End	Start	End	Start	End
S40	8996	5398	8852	5254	12415	8816	15977	12379	23102	19504	26665	23066	30227	26629
S50	11246	6747	7503	3004	11065	6567	14628	10129	21753	17254	25315	20817	28878	24379
S60	13495	8097	-	-	9716	4318	13278	7880	20403	15005	23966	18568	27528	22130
S70	15744	9446	-	-	-	-	11929	5631	19054	12756	22617	16319	26179	19881
S80	17993	10795	-	-	-	-	10580	3382	17705	10507	21267	14070	24830	17632
S90	20242	12145	-	-	-	-	-	-	16355	8258	19918	11821	23480	15383
S1C	22491	13494	-	-	-	-	-	-	15006	6009	18568	9571	22131	13134



www.Hytork.com

Copyright © Emerson Process Management. The information in this document is subject to change without notice.

Updated data sheets can be obtained from our website [www.hytork.com](http://www.hytork.com) or from your nearest Valve Automation Center

USA: +1 813 630 2255 (fax 630 9449) UK: +44 191 5180020 (fax 5180032)



**EMERSON**  
Process Management