

Data sheet

Sheet No.: D36, Rev. A

Date: Sept. 2005

Hytorc XL

Envelope Dimensions and Torque Data

XL1126 Double acting and Spring Return actuator

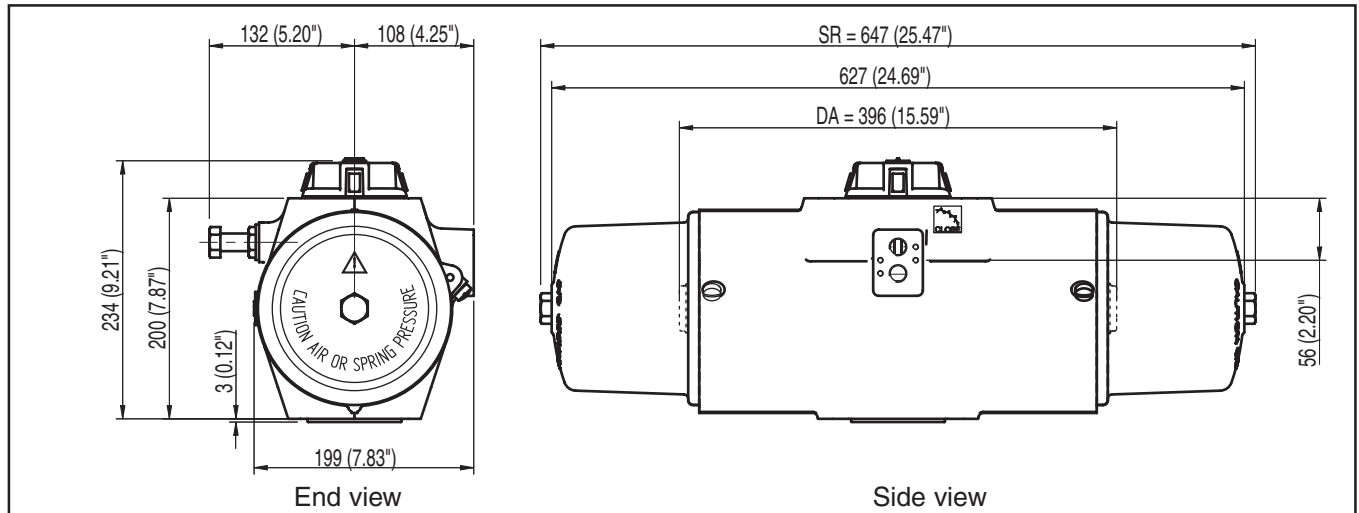

Torque in Nm, Pressure in bar(g)

Double Acting Torques		433		577		722		794		866		1010		1155		
Spring Rating	Torque From Springs		3.0 bar(g)		4.0 bar(g)		5.0 bar(g)		5.5 bar(g)		6.0 bar(g)		7.0 bar(g)		8.0 bar(g)	
	Start	End	Start	End	Start	End	Start	End	Start	End	Start	End	Start	End	Start	End
S40	247	148	285	186	429	330	574	474	646	547	718	619	862	763	1007	907
S50	309	185	248	124	392	268	536	413	609	485	681	557	825	701	970	846
S60	371	222	211	62	355	206	499	351	572	423	644	495	788	639	932	784
S70	433	259	-	-	318	145	462	289	535	361	607	433	751	578	895	722
S80	495	296	-	-	281	83	425	227	497	299	570	371	714	516	858	660
S90	556	334	-	-	-	-	388	165	460	237	533	310	677	454	821	598
S1C	618	371	-	-	-	-	351	103	423	176	495	248	640	392	784	537

Torque in inch-pounds, Pressure in PSI

Double Acting Torques		3500		4375		5250		7000		7875		8750		10500		
Spring Rating	Torque From Springs		40 PSI		50 PSI		60 PSI		80 PSI		90 PSI		100 PSI		120 PSI	
	Start	End	Start	End	Start	End	Start	End	Start	End	Start	End	Start	End	Start	End
S40	2189	1312	2188	1311	3063	2186	3938	3061	5688	4811	6563	5686	7438	6561	9188	8311
S50	2736	1640	1860	764	2735	1639	3610	2514	5360	4264	6235	5139	7110	6014	8860	7764
S60	3283	1968	-	-	2407	1092	3282	1967	5032	3717	5907	4592	6782	5467	8532	7217
S70	3830	2296	-	-	2079	545	2954	1420	4704	3170	5579	4045	6454	4920	8204	6670
S80	4377	2624	-	-	-	-	2626	873	4376	2623	5251	3498	6126	4373	7876	6123
S90	4925	2952	-	-	-	-	-	-	4048	2075	4923	2950	5798	3825	7548	5575
S1C	5472	3280	-	-	-	-	-	-	3720	1528	4595	2403	5470	3278	7220	5028

HYTORK

www.Hytorc.com

Copyright © Emerson Process Management. The information in this document is subject to change without notice.

Updated data sheets can be obtained from our website www.hytorc.com or from your nearest Valve Automation Center

USA: +1 813 630 2255 (fax 630 9449) UK: +44 191 5180020 (fax 5180032)



EMERSON
Process Management