

**Data sheet**

Sheet No.: D34, Rev. C  
 Date: December 2011

**Hytork XL**

# Envelope Dimensions and Torque Data

## XL426 Double acting and Spring Return actuator

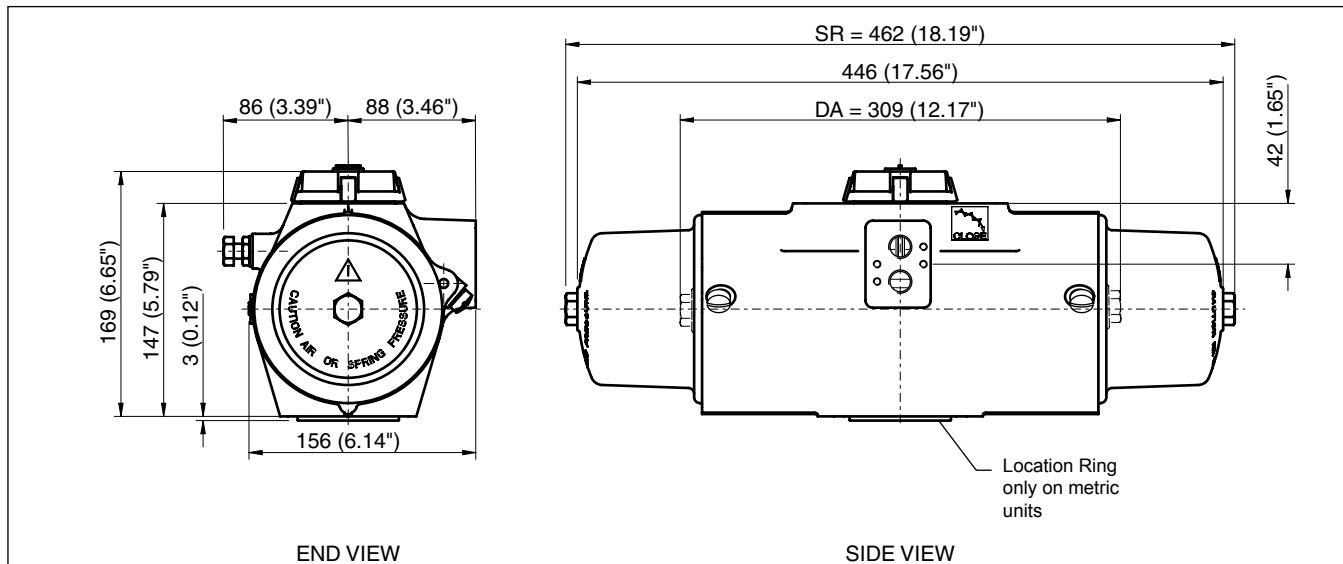

Torque in Nm, Pressure in bar(g)																
Double Acting Torques		159		212		264		291		317		370		423		
Spring Rating	Torque From Springs		3.0 bar(g)		4.0 bar(g)		5.0 bar(g)		5.5 bar(g)		6.0 bar(g)		7.0 bar(g)		8.0 bar(g)	
	Start	End	Start	End	Start	End	Start	End	Start	End	Start	End	Start	End	Start	End
S40	94	56	102	65	155	118	208	171	235	197	261	223	314	276	367	329
S50	117	70	88	41	141	94	194	147	221	174	247	200	300	253	353	306
S60	141	84	-	-	127	71	180	124	206	150	233	177	286	229	339	282
S70	164	99	-	-	113	47	166	100	192	127	219	153	272	206	325	259
S80	188	113	-	-	-	-	152	77	178	103	205	130	258	182	311	235
S90	211	127	-	-	-	-	138	53	164	80	191	106	244	159	296	212
S1C	235	141	-	-	-	-	-	-	150	56	177	83	229	136	282	188

Torque in inch-pounds, Pressure in PSI																
Double Acting Torques		1283		1603		1924		2565		2886		3206		3848		
Spring Rating	Torque From Springs		40 PSI		50 PSI		60 PSI		80 PSI		90 PSI		100 PSI		120 PSI	
	Start	End	Start	End	Start	End	Start	End	Start	End	Start	End	Start	End	Start	End
S40	831	498	784	452	1105	772	1425	1093	2067	1734	2387	2055	2708	2375	3349	3017
S50	1039	623	659	244	980	564	1301	885	1942	1526	2263	1847	2583	2168	3224	2809
S60	1246	748	-	-	855	357	1176	677	1817	1319	2138	1639	2459	1960	3100	2601
S70	1454	872	-	-	-	-	1051	470	1693	1111	2013	1431	2334	1752	2975	2393
S80	1662	997	-	-	-	-	927	262	1568	903	1889	1224	2209	1544	2851	2186
S90	1870	1122	-	-	-	-	-	-	1443	695	1764	1016	2085	1337	2726	1978
S1C	2077	1246	-	-	-	-	-	-	1319	488	1639	808	1960	1129	2601	1770



www.hytork.com

Copyright © Emerson Process Management. The information in this document is subject to change without notice.  
 Updated data sheets can be obtained from our web site [www.hytork.com](http://www.hytork.com) or from your nearest Valve Automation Center  
 USA: +1 813 630 2255 (fax 630 9449) UK: +44 191 5180020 (fax 5180032)



**EMERSON**  
 Process Management