

Data sheet

Sheet No.: D103, Rev. D

Date: June 2005

Hytorc XL

NAMUR Solenoid Mounting details

XL26 to XL4581 Imperial Actuators

XL26 - XL221

XL281 - 4581

**Additional for
XL2586 and XL4581**

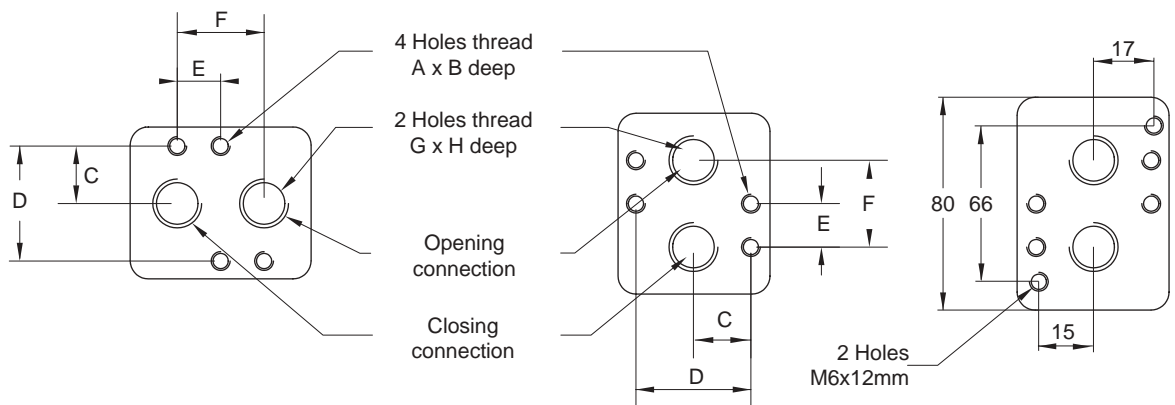

Model	A unc	B	C	D	E	F	G	H
XL26 to XL4581	No10 x 24	0.315"	0.63"	1.26"	0.47"	0.94"	1/4" NPT	0.47"

Optional Highflow 1/2" NPT XL2586 to XL4581

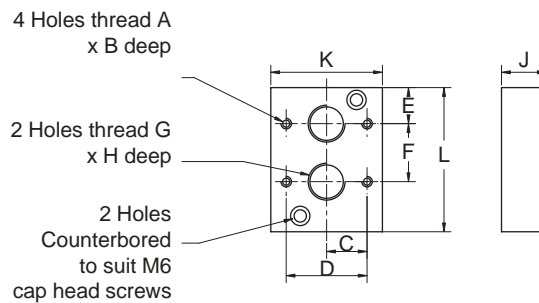

Model	A unc	B	C	D	E	F	G	H	J	K	L
XL2586 & XL4581	1/4"	0.315"	0.90"	1.80"	0.80"	1.30"	1/2" NPT	0.55"	1.0"	2.5"	3.23"



www.Hytorc.com

Copyright © Emerson Process Management. The information in this document is subject to change without notice.

Updated data sheets can be obtained from our website www.hytorc.com or from your nearest Valve Automation Center

USA: +1 813 630 2255 (fax 630 9449) UK: +44 191 5180020 (fax 5180032)



EMERSON
Process Management