

Product data sheet

Sheet No.: 1.606.03 - Rev: C

Date: November 2007

FieldQ

Actuator assembly codes

Double acting assembly codes

Standard assembly code: (= Clock Wise Rotation)	CW
---	-----------

Visual indicator mounted: (= for In line position indication)	I
---	----------

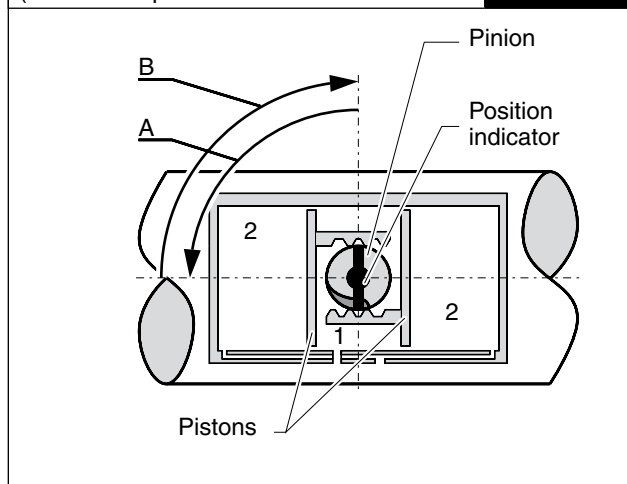

Optional assembly code: (= Counter Clock Wise Rotation)	CC
---	-----------

Visual indicator mounted: (= for In line position indication)	I
---	----------

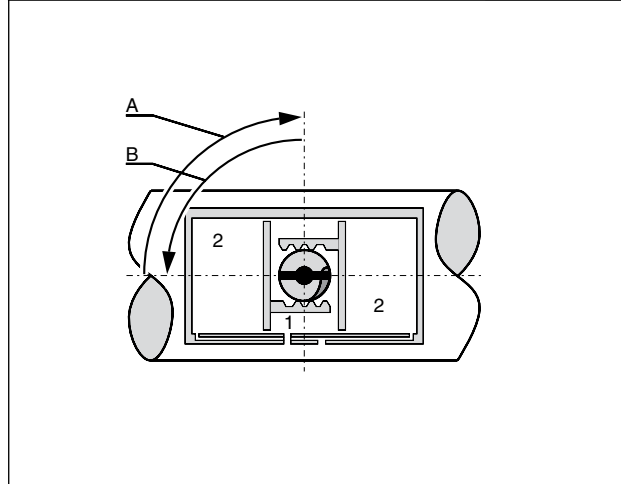

Optional assembly code: (= Clock Wise Rotation)	CW
---	-----------

Visual indicator mounted: (= for Cross line position indication)	C
--	----------

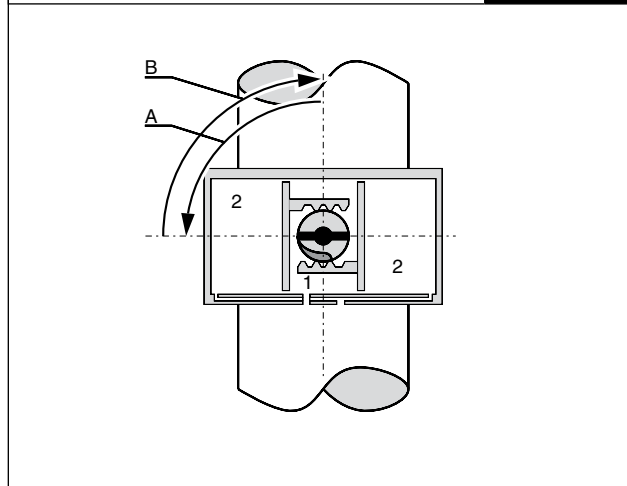

Optional assembly code: (= Counter Clock Wise Rotation)	CC
---	-----------

Visual indicator mounted: (= for Cross line position indication)	C
--	----------

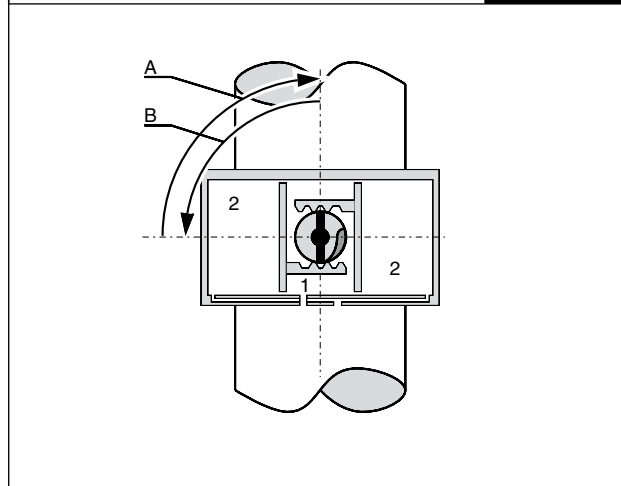

- A = Pilot valve operated** in Control Module - Central air chamber (1) pressurized
B = Pilot valve not operated in Control Module - End cap air chambers (2) pressurized

All views are from above. Pistons are shown in inner position



www.FieldQ.com

Copyright © Emerson Process Management. The information in this document is subject to change without notice. Updated data sheets can be obtained from our web site www.Fieldq.com or from your nearest Valve Automation Center:

America's: +1 813 630 2255 (fax +1 630 9449) Europe: +31 74 256 10 10 (fax +31 74 291 09 38) Asia/Pacific: +65 626 24 515 (fax +65 626 80 028)



EMERSON
Process Management