

## Product data sheet

Sheet No.: 1.606.02 - Rev: B  
Date: October 2005

FieldQ

# FieldQ valve actuator

## Failure modes

### Valve rotation

Valves are normally manufactured so that:

1 The valve is closed : after a clock wise rotation\*

2 The valve is open : after a counter clock wise rotation\*

\*) = views from above

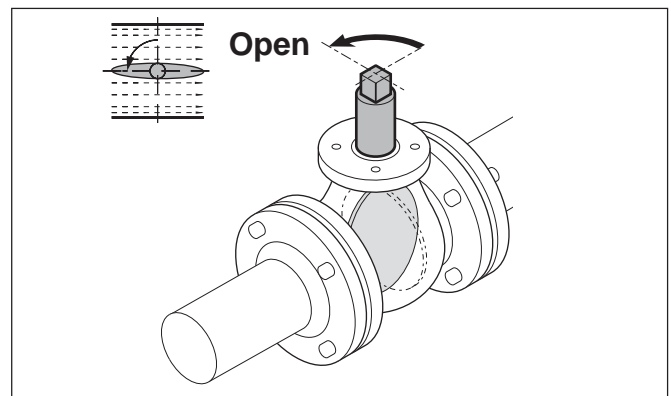
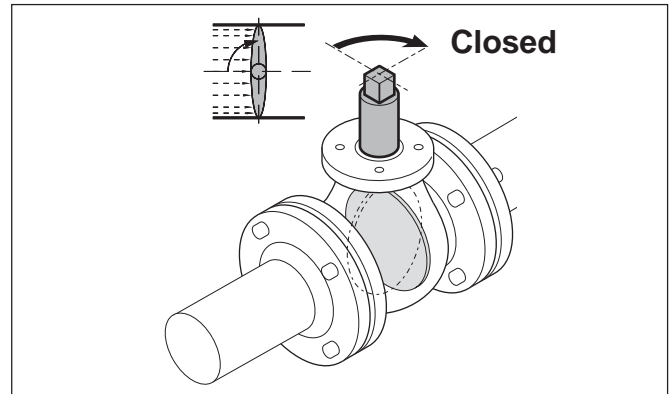

## Position after a failure

The position of the actuator after a failure depends on:

- 1 Principles of operation  
Spring Return or Double Acting
- 2 Actuator assembly code  
See 1.606.03 for Double Acting  
See 1.606.04 for Spring Return
- 3 Kind of failure See table.

Principle of operation:	Assembly code :	Kind of failure :	Position :
Double acting actuator	CW	Pressure	not defined
		Signal	Closed
		Supply voltage	Closed
	CC	Pressure	not defined
		Signal	Open
		Supply voltage	Open
Single acting actuator (Spring Return)	CW	Pressure	Closed
		Signal	Closed
		Supply voltage	Closed
	CC	Pressure	Open
		Signal	Open
		Supply voltage	Open



www.FieldQ.com

Copyright © Emerson Process Management. The information in this document is subject to change without notice. Updated data sheets can be obtained from our web site [www.Fieldq.com](http://www.Fieldq.com) or from your nearest Valve Automation Center: **America's:** +1 813 630 2255 (fax +1 630 9449) **Europe:** +31 74 256 10 10 (fax +31 74 291 09 38) **Asia/Pacific:** +65 626 24 515 (fax +65 626 80 028)



**EMERSON**  
Process Management