

Product data sheet

Sheet No.: 1.605.01 - Rev: A, Page 1 of 2

Date: August, 2006

FieldQ

Pneumatic Module

Description:

The Pneumatic Module is the pneumatic interface between the Control Module and the actual actuator. It controls the incoming and outgoing airflow. These modules are available in two basic executions:

- Single acting (for spring return actuators)
- Double acting

Valve block:

The Pneumatic Module contains a valve block with two or four diaphragm/poppet valves (for single acting or double acting executions). The valves are operated by a pilot valve in the Control Module.

To assure trouble-free operation, the valve block is equipped with big ports. This enables a large air flow and to makes it less sensitive for contamination of the internals. The large air flow also enables it to be utilized for the entire FieldQ range.

Breather Function:

The spring return models have standard a built in "Breather" function. During the spring stroke, the exhaust air from the center chamber is first fed to the spring chamber preventing air from outside from being sucked into the spring chamber. This reduces the possibility of internal corrosion and maximizes the actuators' working life.

Options

Speed Control

Two integrated speed control options are available:

- 1 Speed control which throttles the air flow in one direction (exhausted air).
- 2 Speed control which throttles the air flow in both directions (supplied and exhausted air).

For more information on speed control see sheet 1.605.02 page 2.

Silencers and vents

The Pneumatic Module can be equipped with either silencers or vents. Dedicated IP65/NEMA4x rated vents are available.

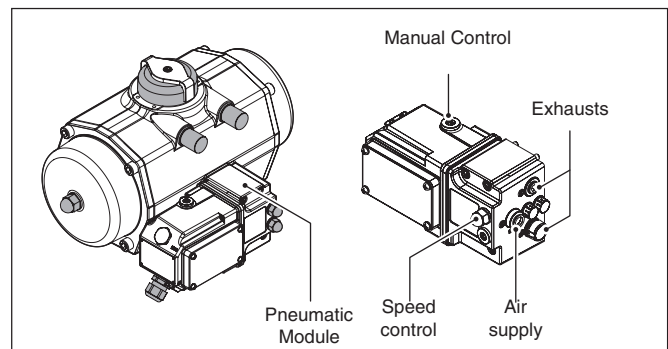

Manual Control

For commissioning, emergency or maintenance purposes, the FieldQ can be supplied with Manual Control options. These options can operate the actuator when there is air pressure available, but no control signal or power supply. Two versions are available:

- Push
- Push and lock

For more detailed information see data sheet 1.604.50

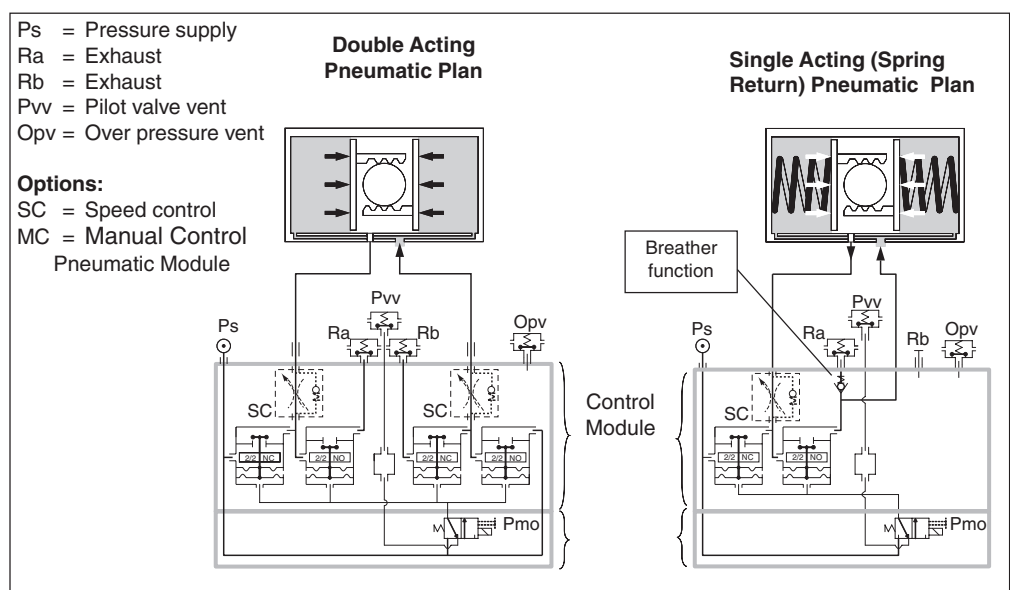

www.FieldQ.com

Copyright © Emerson Process Management. The information in this document is subject to change without notice. Updated data sheets can be obtained from our web site www.FieldQ.com or from your nearest Valve Automation Center: **America's:** +1 813 630 2255 (fax +1 630 9449) **Europe:** +31 74 256 10 10 (fax +31 74 291 09 38) **Asia/Pacific:** +65 626 24 515 (fax +65 626 80 028)



EMERSON
Process Management

Product data sheet

Sheet No.: 1.605.01 - Rev: A, Page 2 of 2

Date: August, 2006

FieldQ

Specification Pneumatic Module

Function : Double or Single Acting (spring return)

"Breather" function : Standard for single acting actuators

Pressure range

- Double acting : 2 to 8 bar g / 30 to 120psig
- Spring return : 6 to 8 bar g / 87 to 120psig with maximum spring set.
: 3 to 8 bar g / 43 to 120psig with reduced spring set.

Enclosure : IP65/NEMA4X

Air entry : G1/4" or 1/4"NPT

Exhaust ports : G1/4" or 1/4"NPT

Operating media

Air or inert gasses, filtered at 50 micrometer. The following Control Modules require air filtered at 5 micrometer: QC03, QC04, and QC34. See applicable data sheets 1.604.xx.

Temperature

Depends on the utilized Control Module. See applicable data sheets 1.604.xxx.

Base Materials

Body	: Aluminium
Valve housing	: 30% glass-filled Nylon
Finish	: Polyester non-TGIC based powder coating
Valve seats	: Buna-N
Membrane	: Buna-N
Fasteners	: Stainless Steel

Optional parts

1 Plug	NPT	: Steel, zinc plated
	BSP	: Brass, nickel plated
2 Vents		: Stainless Steel (AISI 303)
3 Exhaust	Base	: Nylon
	Cover	: Zinc Nickel plated and transparent passivated
	Option	: Plastic silencer (nylon)
4 Speed Control		
- Throttle		: Stainless Steel (AISI 303)
- Nut Cover		: Nylon PA6
5 Plug		: Brass Nickel plated
6 Manual Control		
- Plug		: Brass Nickel plated
- Push		: Red anodized aluminum
- Push & Lock		: Red anodized aluminum

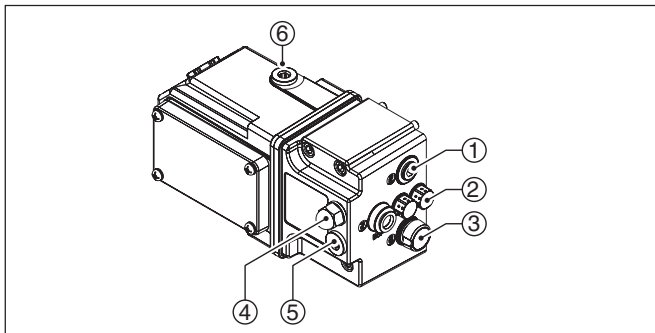

www.FieldQ.com

Copyright © Emerson Process Management. The information in this document is subject to change without notice. Updated data sheets can be obtained from our web site www.Fieldq.com or from your nearest Valve Automation Center: **America's:** +1 813 630 2255 (fax +1 630 9449) **Europe:** +31 74 256 10 10 (fax +31 74 291 09 38) **Asia/Pacific:** +65 626 24 515 (fax +65 626 80 028)



EMERSON
Process Management