

Product data sheet

Sheet No.: 1.603.04 - Rev: A
Date: September, 2006

FieldQ

FieldQ Valve Actuator Dimensions

Imperial Actuators - ISO5211

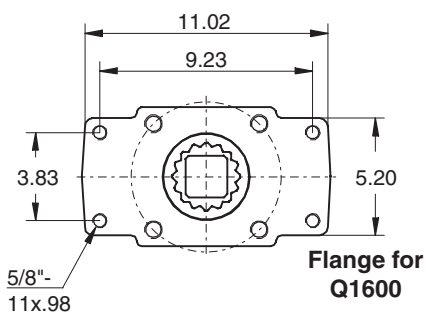
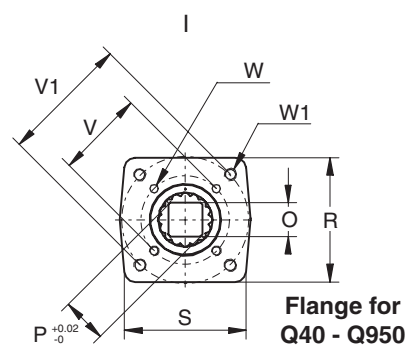
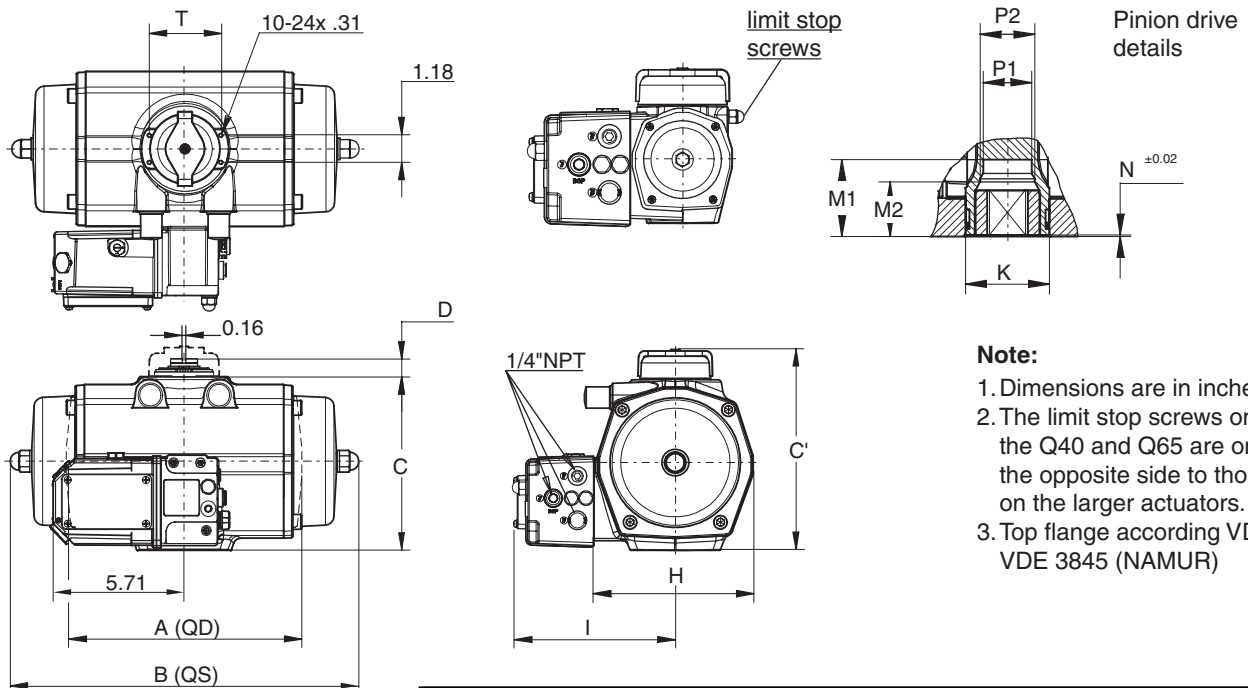

*) Four holes of the F25 ISO Drilling pattern

Dim. inches	FieldQ™ actuator models								
	Q40	Q65	Q100	Q150	Q200	Q 350	Q600	Q950	Q1600
A QD	7.09	7.83	8.70	12.20	11.14	12.01	15.24	16.69	20.31
B QS	7.95	9.80	10.00	8.31	14.09	15.35	16.50	18.09	22.34
C	4.09	4.59	5.55	5.91	6.30	7.52	9.65	10.87	13.27
C'	5.39	5.92	6.89	7.24	7.64	8.86	11.38	12.56	14.96
D	0.79	0.79	0.79	0.79	0.79	0.79	1.18	1.18	1.18
H	3.54	4.02	4.53	5.08	5.31	6.97	8.23	9.21	10.55
I	5.04	5.58	5.55	6.22	5.87	6.73	7.36	7.87	8.54
K	1.30	1.30	1.50	2.17	2.17	2.17	2.68	2.95	3.74
M1	1.36	1.36	1.36	1.97	1.97	1.97	1.97	2.56	3.19
M2	-	-	1.06	-	1.46	1.46	-	-	-
N	0.04	0.04	0.06	0.04	0.06	0.06	0.06	0.06	0.06
O max.	0.556	0.556	0.753	0.753	0.871	1.068	1.068	1.424	1.817
O min.	0.551	0.551	0.748	0.748	0.866	1.063	1.063	1.417	1.811
P	0.71	0.71	0.99	0.99	1.11	1.43	1.43	1.90	2.37
P1	0.71	0.83	0.93	1.12	1.27	1.27	1.45	1.90	2.38
P2	-	-	0.99	-	1.43	1.43	-	-	-
R	2.56	2.76	2.76	3.54	3.54	4.49	4.88	5.12	6.06
S	2.56	2.76	2.76	3.54	3.54	4.49	4.88	5.59	11.02
T	3.15	3.15	3.15	3.15	3.15	3.15	5.12	5.12	5.12
PCD	F05/F07	F05/F07	F05/F07	F07/F10	F07/F10	F07/F10	F10/F12	F10/F14	F16/F25*
V	1.969	1.969	1.969	2.756	2.756	2.756	4.016	4.016	6.496
V1	2.756	2.756	2.756	4.016	4.016	4.016	4.921	5.512	-
W	1/4"- 20x.39	1/4"- 20x.39	1/4"- 20x.39	5/16"- 18x.39	5/16"- 18x.39	5/16"- 18x.39	3/8"- 16x.63	3/8"- 16x.63	3/4"- 10x1.14
W1	5/16"- 18x.39	5/16"- 18x.39	5/16"- 18x.39	3/8"- 16x.63	3/8"- 16x.63	3/8"- 16x.63	1/2"- 13x.79	5/8"- 11x.98	-



www.FieldQ.com

Copyright © Emerson Process Management. The information in this document is subject to change without notice. Updated data sheets can be obtained from our web site www.Fieldq.com or from your nearest Valve Automation Center: **America's:** +1 813 630 2255 (fax +1 630 9449) **Europe:** +31 74 256 10 10 (fax +31 74 291 09 38) **Asia/Pacific:** +65 626 24 515 (fax +65 626 80 028)



EMERSON
Process Management