

Product data sheet

Sheet No.: 1.603.02 - Rev: B
Date: September, 2006

FieldQ

FieldQ Valve Actuator Dimensions

Metric Actuators - DIN3337

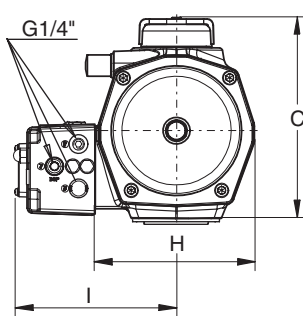
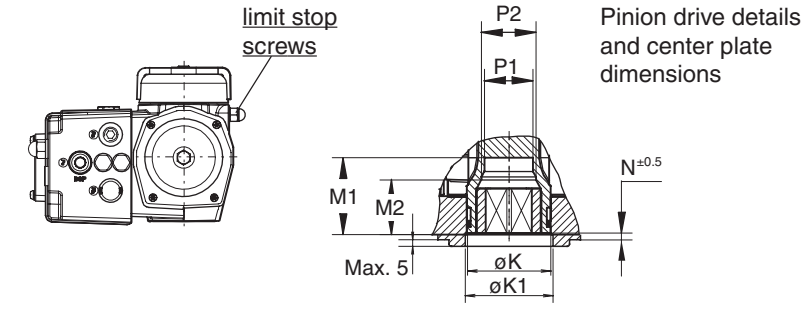
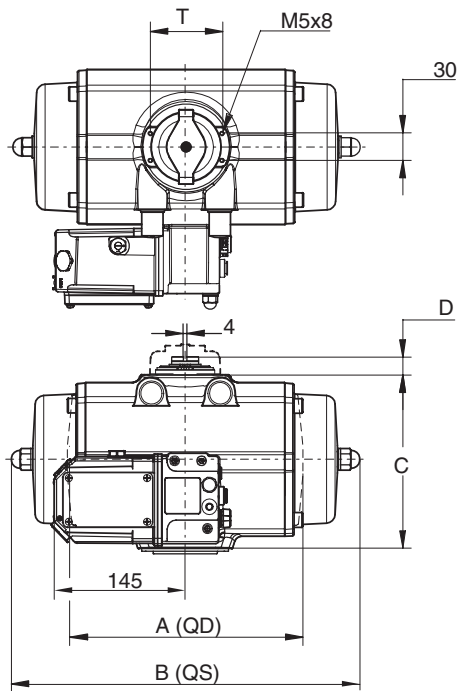

- Note:**
1. Dimensions are metric (mm).
 2. The limit stop screws on the Q40 and Q65 are on the opposite side to those on the larger actuators.
 3. Top flange according VDI/VDE 3845 (NAMUR)

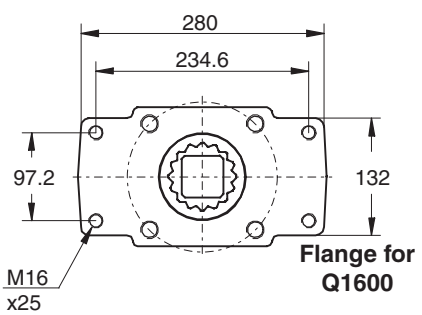
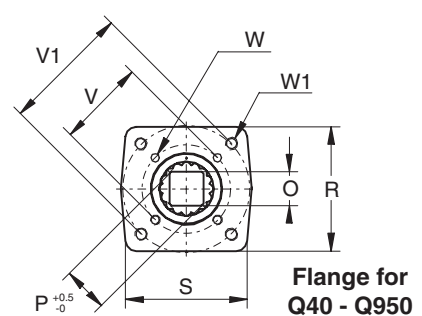

*) Four holes of the F25 Drilling pattern

Dim.	FieldQ™ actuator models									
in mm.	Q40	Q65	Q100	Q150	Q200	Q 350	Q600	Q950	Q1600	
A QD	180	199	221	310	283	305	387	424	516	
B QS	202	249	254	211	358	390	419	460	568	
C	104	117	141	150	160	191	245	276	337	
C'	137	150	175	184	194	225	289	319	380	
D	20	20	20	20	20	20	30	30	30	
H	90	102	115	129	135	177	209	234	268	
I	128	142	141	158	149	171	187	200	217	
K	33	33	38	55	55	55	68	75	95	
K1	32	32	40	50	54	54	68	75	95	
M1	34.5	34.5	34.5	50	50	50	50	65	81	
M2	-	-	27	-	37	37	-	-	-	
N	1	1	1.5	1	1.5	1.5	1.5	1.5	1.5	
O max.	14.11	14.11	17.13	17.13	22.13	27.13	27.13	36.16	46.16	
O min.	14.00	14.00	17.00	17.00	22.00	27.00	27.00	36.00	46.00	
P	18.1	18.1	22.2	22.2	28.2	36.2	36.2	48.2	60.2	
P1	18.1	21.2	23.1	28.5	32.2	36.5	36.8	48.3	60.5	
P2	-	-	25.2	-	36.2	-	-	-	-	
Q	35	70	55	55	70	70	85	100	130	
R	65	70	70	90	90	114	124	130	154	
S	65	70	70	90	90	114	124	142	280	
T	80	80	80	80	80	80	130	130	130	
PCD	F05	F05	F07	F07	F10	F10	F12	F14	F16	
V	50	50	70	70	102	102	125	140	165	
W	M6x	M6x	M8x	M8x	M10x	M10x	M12x	M16x	M20x	
	10	10	13	13	16	16	20	25	30	
Optional dimensions										
K1'	40	40	32	54	50	50	-	-	-	
Q'	55	35	35	70	55	55	-	-	-	
PCD	F07	F07	F05	F10	F07	F07	F10	F10	F25*	
V'	70	70	50	102	70	70	102	102	-	
W'	M8x	M8x	M8x	M10x	M10x	M10x	M12x	M16x	-	
	13	13	13	16	16	16	20	25	-	



www.FieldQ.com

Copyright © Emerson Process Management. The information in this document is subject to change without notice. Updated data sheets can be obtained from our web site www.Fieldq.com or from your nearest Valve Automation Center: **America's:** +1 813 630 2255 (fax +1 630 9449) **Europe:** +31 74 256 10 10 (fax +31 74 291 09 38) **Asia/Pacific:** +65 626 24 515 (fax +65 626 80 028)

