

Data sheet

Sheet No.: A4.204.02 Rev.B

Date: June 2009

EL-O-MATIC ACTUATOR WITH CSR COATING

CSR

Description

EL-O-MATIC CSR-actuators have an excellent corrosion resistance in environments where the actuator is in contact with chemicals like caustic soda. The CSR coating itself is resistant to at least 1000 hours of salt spray test exposure. Together with the excellent mechanical properties, the CSR coating is "the" solution for very harsh environments.

CSR actuator housing and caps are completely coated (inside and out) with a ceramic filled fluoropolymer based epoxy resin, impregnated by a temperature of 240°C into the aluminum surface.

Approximately 40% of the coating is impregnated into the aluminum, 60% stays on the surface of the component as a seal.

Technical data

Coating	: Ceramic filled fluoropolymer based epoxy resin
Layer thickness	: 20 microns
Salt spray test	: DIN 50021 / ASTM B117: 1000 hours
Max. temperature	: -4° to 176°F (20° to + 80°C)
Materials	: Housing : Aluminum alloy
	: Shaft : Aluminum hard anodized
	: (Option : Stainless steel)
	: Fasteners : Stainless steel
	: Tagplate : Stainless steel
Application	: Optional on all EL-O-MATIC actuators

Chemical resistances

Resistance to various inorganic chemicals, organic chemicals, gasolines, oils, detergents, etc. is generally good to excellent, but also depends on temperature and/or concentration. More detailed information available at data sheet A4.204.021

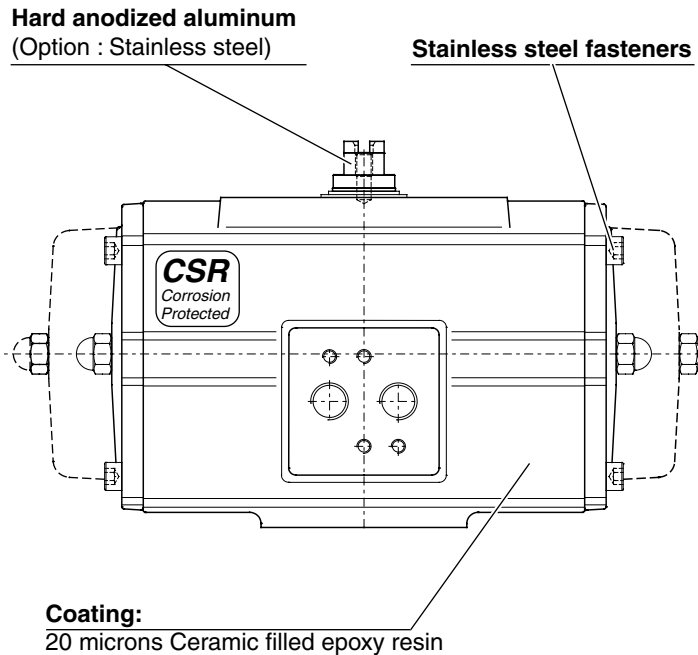

EL-O-MATIC™

www.El-O-matic.com

Copyright © Emerson Process Management. The information in this document is subject to change without notice.

Updated data sheets can be obtained from our website www.El-O-Matic.com or from your nearest Valve Automation Center **USA:** +1 813 319 0266 **Europe:** +31 74 256 10 10 **Asia-Pacific:** +65 6501 4600

EMERSON™
Process Management