

# Data sheet

Sheet No.: A1.204.02 Rev. C  
Date: June 2010

## 180° SPRING RETURN ACTUATOR TORQUE (In.lb.)

180°

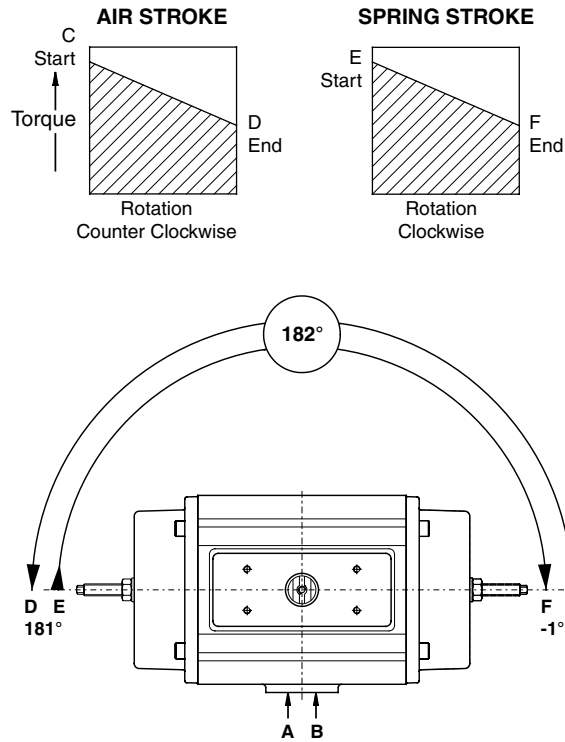

### Note

- Emerson Process Management recommends that the valve manufacturer supply the maximum required torque values (Including any adjustments or suggested safety factors for valve service conditions or application).  
Additionally, the valve manufacturer must identify at which position(s) and direction(s) of rotation (Counter Clock Wise or Clock Wise) these maximum requirements occur.
- If in doubt, or you require any assistance with sizing actuators, do not hesitate to contact your nearest Emerson's Valve Automation Division representative.
- Pressure on port "A" opens the actuator\*
- The actuator is shown in closed position\*
- Do not exceed the maximum supply pressure of 6 bar / 87psi.  
(\*code A, data sheet A1.504)

Actuator type	Spring nr.	Air Stroke (in.lb.)										Spring Stroke (in.lb.)	
		SUPPLY PRESSURE (PSI)											
		40		50		60		70		80		E	F
ES12	2	-	-	33	9	49	25	65	41	81	57	63	41
PE60	8	70	19	105	55	141	90	176	125	212	161	112	62
	10	-	-	88	24	123	60	159	95	194	131	141	78
	12	-	-	-	-	106	30	142	65	177	101	169	93
	14	-	-	-	-	-	-	124	35	160	71	197	109
PE150	8	185	76	274	165	364	255	453	344	543	433	258	150
	10	-	-	233	96	322	186	411	275	501	365	322	187
	12	-	-	-	-	280	117	370	206	459	296	387	225
	14	-	-	-	-	239	48	328	137	418	227	451	262
PE280	8	-	-	493	193	662	361	830	530	999	698	597	303
	10	-	-	-	-	578	202	746	370	915	539	746	379
	12	-	-	-	-	-	-	662	211	830	379	896	455
	14	-	-	-	-	-	-	-	-	746	220	1045	531
PE500	8	-	-	965	256	1263	554	1561	852	1859	1149	1134	452
	10	-	-	-	-	1138	251	1435	549	1733	847	1417	565
	12	-	-	-	-	-	-	-	-	1608	544	1701	678
	14	-	-	-	-	-	-	-	-	-	-	1984	791
PE750	8	-	-	1470	549	1913	992	2356	1434	2799	1877	1529	641
	10	-	-	-	-	1735	583	2178	1026	2621	1469	1912	801
	12	-	-	-	-	-	-	2000	618	2443	1060	2294	961
	14	-	-	-	-	-	-	-	-	2265	652	2676	1121
PE1100	8	1454	430	2108	1083	2761	1736	3414	2389	4067	3043	1999	1000
	10	-	-	1830	549	2483	1202	3136	1855	3790	2509	2499	1250
	12	-	-	-	-	2205	668	2858	1321	3512	1975	2999	1500
	14	-	-	-	-	-	-	2581	787	3234	1441	3499	1750
PE2500	8	2625	890	4124	2389	5622	3888	7121	5386	8620	6885	4675	2934
	10	-	-	3309	1140	4807	2639	6306	4137	7804	5636	5844	3668
	12	-	-	2494	-109	3992	1390	5491	2889	6989	4387	7013	4401
	14	-	-	-	-	3177	141	4676	1640	6174	3138	8182	5135
PE4000	8	4475	1548	7015	4088	9555	6628	12096	9169	14636	11709	7890	4952
	10	-	-	5639	1981	8180	4521	10720	7061	13260	9602	9863	6190
	12	-	-	4264	-127	6804	2414	9344	4954	11885	7494	11835	7429
	14	-	-	-	-	5428	306	7969	2847	10509	5387	13808	8667



www.El-O-matic.com

Copyright © Emerson Process Management. The information in this document is subject to change without notice.

Updated data sheets can be obtained from our website [www.El-O-Matic.com](http://www.El-O-Matic.com) or from your nearest Valve Automation Center **USA:** +1 813 319 0266 **Europe:** +31 74 256 10 10 **Asia-Pacific:** +65 6501 4600



**EMERSON**  
Process Management