

Data sheet

Sheet No.: A1.204.01 Rev. C
Date: June 2010

180° DOUBLE ACTING ACTUATOR TORQUE (In.lb.)

180°

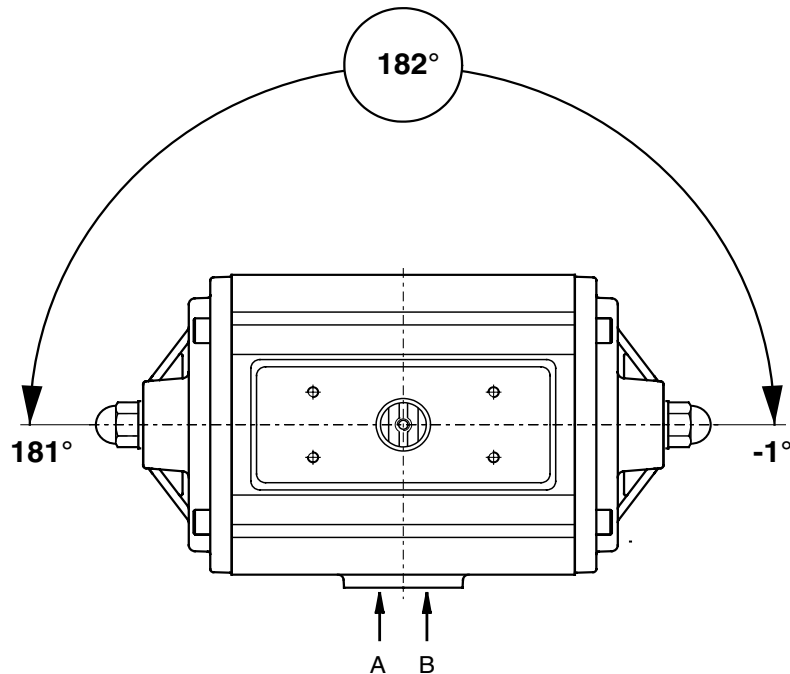
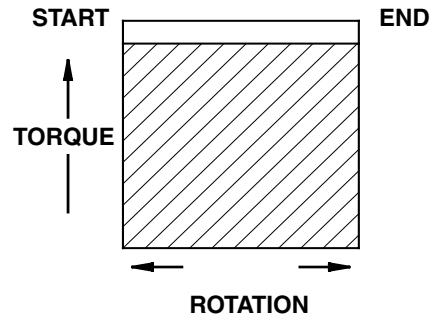

Actuator type	Torque (in in.lb) Supply Pressure (PSI)					
	30	40	50	60	70	80
ED 12	44	59	74	89	104	119
PD 60	104	139	175	210	245	281
PD 150	262	351	441	530	620	709
PD 280	493	662	830	999	1167	1336
PD 500	872	1170	1467	1765	2063	2361
PD 750	1297	1740	2182	2625	3068	3511
PD 1100	1912	2566	3219	3872	4525	5179
PD 2500	4407	5913	7418	8923	10429	11934
PD 4000	7440	9981	12522	15064	17605	20146

Note

- Emerson Process Management recommends that the valve manufacturer supply the maximum required torque values (Including any adjustments or suggested safety factors for valve service conditions or application).
Additionally, the valve manufacturer must identify at which position(s) and direction(s) of rotation (Counter Clock Wise or Clock Wise) these maximum requirements occur.
- If in doubt, or you require any assistance with sizing actuators, do not hesitate to contact your nearest Emerson's Valve Automation Division representative.
- Pressure on port "A" opens the actuator*
- The actuator is shown in closed position*
- Do not exceed the maximum supply pressure of 6 bar / 87psi.
(*code A, data sheet A1.503)

EL-O-MATIC™

www.El-O-matic.com

Copyright © Emerson Process Management. The information in this document is subject to change without notice.

Updated data sheets can be obtained from our website www.El-O-Matic.com or from your nearest Valve Automation Center **USA:** +1 813 319 0266 **Europe:** +31 74 256 10 10 **Asia-Pacific:** +65 6501 4600



EMERSON™
Process Management