

# Data sheet

Sheet No.: A1.203.011 Rev. A  
Date: November 2009

## DIMENSION SHEET STANDARD 180° ACTUATOR

180°

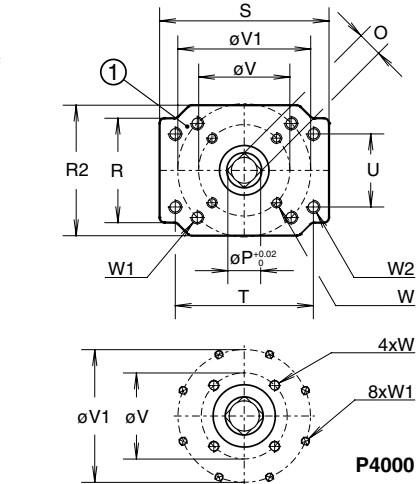
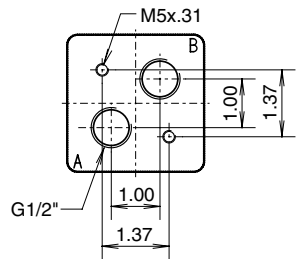
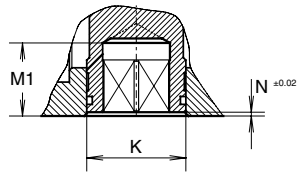
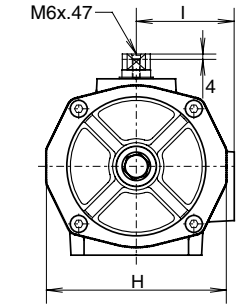
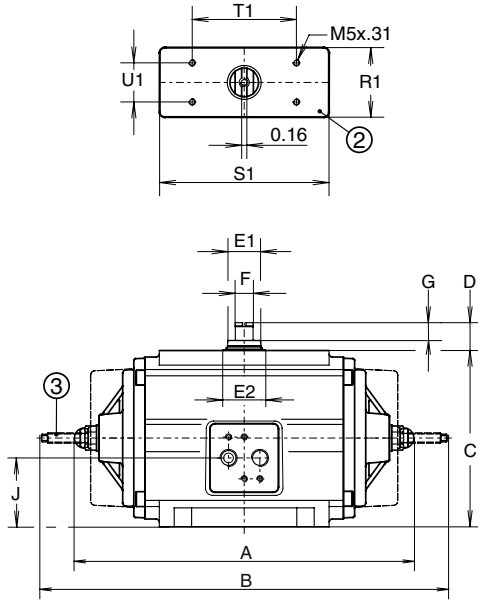
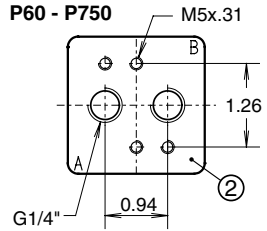

P1100 - P4000

P4000

Dim. in mm.	ACTUATOR TYPE								
	E12	P60	P150	P280	P500	P750	P1100	P2500	P4000
A DA		9.17	11.61	13.94	16.30	17.60	19.76	24.92	29.61
B SR		10.08	13.07	17.09	19.57	21.77	25.24	32.17	42.95
C		3.98	5.31	6.30	7.48	9.21	9.72	14.02	14.96
D		0.79	0.79	0.79	1.18	1.18	1.18	1.18	1.18
E1		0.63	0.87	1.02	1.42	1.42	1.77	2.17	2.52
E2		0.91	1.18	1.38	1.77	1.77	2.17	2.56	3.15
F		0.39	0.55	0.55	0.75	0.75	1.18	1.42	1.42
G		0.47	0.47	0.47	0.75	0.75	0.39	0.39	0.39
H		3.98	5.43	6.61	7.56	9.41	9.84	13.54	14.65
I		2.28	2.95	3.50	4.29	5.28	5.31	7.20	7.87
J		1.69	2.09	2.72	3.74	4.57	4.92	7.01	7.48
K		1.10	1.50	1.89	2.20	2.20	2.95	3.35	4.72
M1		1.06	1.06	1.22	1.50	1.50	2.01	2.60	3.03
N		0.04	0.04	0.06	0.06	0.08	0.10	0.12	0.06
O max.		0.556	0.674	0.871	1.068	1.068	1.424	1.817	2.173
O min.		0.551	0.669	0.866	1.063	1.063	1.417	1.811	2.165
P		0.713	0.992	1.110	1.425	1.425	1.898	2.370	2.843
R		2.36	3.15	3.98	4.37	5.51	5.51	6.69	6.69
R1		2.01	2.36	2.80	3.19	3.94	4.72	6.30	6.30
R2		2.76	3.94	-	-	-	-	-	10.31
S		4.37	5.12	5.55	6.34	8.27	8.27	11.42	11.42
S1		4.37	5.12	5.55	5.55	6.30	8.27	9.65	9.65
T		-	-	-	-	-	-	9.24	-
T1		3.15	3.15	3.15	5.12	5.12	5.12	5.12	5.12
U		-	-	-	-	-	-	3.83	-
U1		1.18	1.18	1.18	1.18	1.18	1.18	1.18	1.18
V		F05	F07	F07	F10	F10	F14	F16	F16
W		1.969	2.756	2.756	4.016	4.016	5.512	6.496	6.496
V1		M6 x .35	M8 x .51	M8 x .51	M10 x .63	M10 x .63	M16 x .79	M20 x1.18	M20 x1.18
W1		F07	F10	F10	F12	F12	-	-	F25
W2		2.756	4.016	4.016	4.921	4.921	-	-	10.000
W1		M8 x .51	M10 x .63	M10 x .63	M12 x .63	M12 x .63	-	-	M16 x 0.98
W2		-	-	-	-	-	-	M16 x 0.98	-

For E12 dimensions see A1.103.102

### Note

1. Flange to ISO 5211, square drive to DIN 3337
2. Top and Solenoid flange to VDI/VDE 3845 (NAMUR).  
P1100 P2500 and P4000 have a non-NAMUR solenoid flange with 1/2" entries.
3. 180° actuators are standard equipped with "L1" limit stops. 120° or 135° rotation is possible with optional LF-option (See data sheet A1.503.01)



www.El-O-matic.com

Copyright © Emerson Process Management. The information in this document is subject to change without notice.

Updated data sheets can be obtained from our website [www.El-O-matic.com](http://www.El-O-matic.com) or from your nearest Valve Automation Center **USA:** +1 813 319 0266 **Europe:** +31 74 256 10 10 **Asia-Pacific:** +65 6501 4600



**EMERSON**  
Process Management