

Data sheet

Sheet No.: A1.104.01 Rev. B
Date: January 2010

DOUBLE ACTING ACTUATOR TORQUE (In.lb.)

90°

DOUBLE ACTING TORQUE

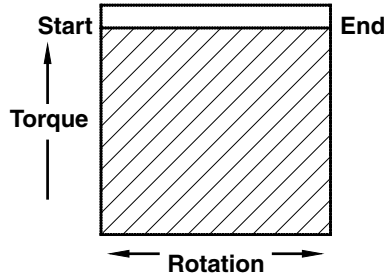

Actuator		Torque of double acting actuators (in In.lb) Supply pressure (psi)												
Type	Size	30	35	40	45	50	55	60	70	75	80	90	100	120
ED	12	43.9	51.4	58.9	66.4	73.9	81.4	88.9	104	111	119	134	149	179
ED	25	81.4	95.3	109	123	137	151	165	193	206	220	248	276	332
ED	40	153	179	205	231	257	283	309	361	387	413	466	518	622
ED	65	233	272	312	352	392	431	471	551	590	630	709	789	948
ED	100	344	402	461	520	578	637	696	813	872	930	1048	1165	1400
ED	150	551	645	739	833	927	1021	1115	1303	1397	1491	1680	1868	2244
ED	200	754	883	1011	1140	1269	1398	1527	1784	1913	2042	2299	2557	3072
ED	350	1310	1534	1757	1981	2205	2428	2652	3100	3323	3547	3994	4442	5337
ED	600	2226	2606	2986	3366	3747	4127	4507	5267	5647	6028	6788	7548	9069
ED	950	3323	3890	4458	5025	5593	6160	6728	7862	8430	8997	10132	11267	13537
ED	1600	5493	6431	7369	8307	9245	10183	11121	12998	13936	14874	16750	18626	22379
PD	2500	8774	10273	11825	13270	14768	16267	17847	20858	22363	23869	26880	29891	35912
PD	4000	14874	17414	19962	22495	25035	27576	30127	35210	37751	40293	45375	50458	60623

Note

- Emerson Process Management recommends that the valve manufacturer supply the maximum required torque values (Including any adjustments or suggested safety factors for valve service conditions or application). Additionally, the valve manufacturer must identify at which position(s) and direction(s) of rotation (Counter Clock Wise or Clock Wise) these maximum requirements occur.
- If in doubt, or you require any assistance with sizing actuators, do not hesitate to contact your nearest Emerson's Valve Automation Division representative.
- Pressure on port "A" opens the actuator*
- The actuator is shown in closed position*

(* code A, data sheet A1.503)

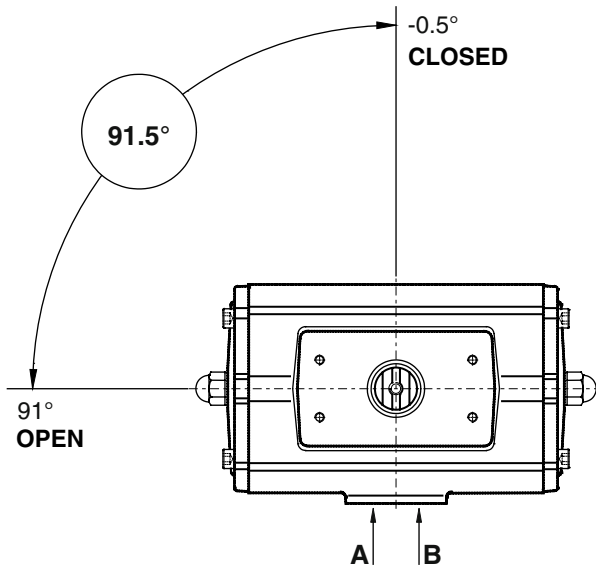

www.El-O-matic.com

Copyright © Emerson Process Management. The information in this document is subject to change without notice.

Updated data sheets can be obtained from our website www.El-O-Matic.com or from your nearest Valve Automation Center **USA:** +1 813 319 0266 **Europe:** +31 74 256 10 10 **Asia-Pacific:** +65 6501 4600



EMERSON
Process Management