

Data sheet

Sheet No.: A1.101.33 Rev. A
Date: November 2009

CONSTRUCTION, PARTS AND MATERIALS E-SERIE ACTUATORS

E

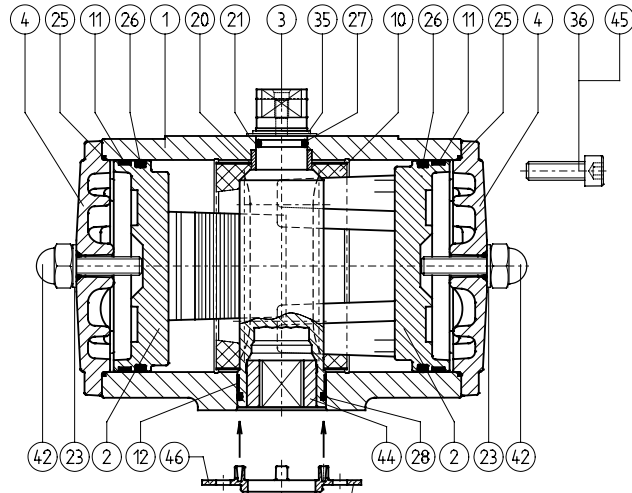

Optional center-plate

Notes

- 1 Hard anodized aluminum alloy: AlZnMgCu1.5, DIN 1725/1
- 2 Deltatone Coating
- 3 Anodized
- 4 Zinc plated and passivated
- 5 CSR Coating (see 4.204.02)
- 6 Stainless Steel Sandvic 1802, SS2382
- 7 Stainless Steel X35CrM017
- 8 No insert, adaptor square direct in pinion

Parts			Materials		Executions		
Nr.	Description	Qty.	Description	Specification	Std	S.S. Shaft	CSR
1	Body	1	Aluminum Alloy	UNS A13600, ASTM B85	-	-	5
2	Piston	2	Aluminum Alloy	UNS A03560, ASTM B26	-	-	-
3	Drive pinion	1	GAISi10Mg, DIN 1725/2	UNS 1 77075, ASTM 7075 T6	1	6	6
4	End Cap ED	2	Aluminum Alloy	UNS A13600, ASTM B85	-	-	5
5	End Cap ES	2	Aluminum Alloy	UNS A13600, ASTM B85	-	-	5
6	Spring- inner	2	Carbon Spring Steel	UNS G10860, ASTM A228	2	2	2
7	Spring- mid	2	Carbon Spring Steel	UNS G10860, ASTM A228	2	2	2
8	Spring- outer	2	Carbon Spring Steel	UNS G10860, ASTM A228	2	2	2
9	Spring Holder	2	Steel	C45, DIN 17200	3	3	3
10	* Guide Band	1	Nylatron	PA6.6 + MoS2	-	-	-
11	* Guide Band	2	PTFE, Carbon filled	PTFE + 25% C	-	-	-
12	* Bearing Bush	1	Nylatron	PA6.6 + MoS2	-	-	-
20	* Bearing Bush	1	Delrin	POM	-	-	-
21	* O-ring	1	Nitrile Rubber	Buna N	-	-	-
22	* Washer ES	2	Nylon	PA6	-	-	-
23	* Washer ED	2	Nylon	PA6	-	-	-
25	* O-ring	2	Nitrile Rubber	Buna N	-	-	-
26	* O-ring	2	Nitrile Rubber	Buna N	-	-	-
27	* Washer	1	ZEDEX 100 K	-	-	-	-
28	* O-ring	1	Nitrile Rubber	Buna N	-	-	-
29	* O-ring	4	Nitrile Rubber	Buna N	-	-	-
30	* O-ring	2	Nitrile Rubber	Buna N	-	-	-
34	Washer ES	2	Steel	C35	3	3	3
35	* Spring Clip	1	Carbon Spring Steel	MIL - R-212 48B	2	7	7
36	End Cap Bolt ED/ES	8	Stainless Steel	AISI 304	-	-	-
37	Limit Stop Bolt ES	2	Stainless Steel	AISI 304	-	-	-
38	Nut	2	Stainless Steel	AISI 304	-	-	-
40	Limit Stop Bolt ED	2	Stainless Steel	AISI 304	-	-	-
41	Nut	2	Stainless Steel	AISI 304	-	-	-
42	Nut Cover	2	Polyethylene	PE	-	-	-
43	* O-ring	2	Nitrile Rubber	Buna N	-	-	-
44	Insert	1	Aluminum Alloy	UNS 1 6082, ASTM 6082	4	9	4
45	Threaded insert	8	Steel	UNS G10430, ASTM A29	3	3	3

* Recommended spare parts (contained in Repair kits)

Remark

All materials are European origin, listed are the nearest US equivalents.

Finish

Standard : Polyester non-TGIC based powder coating
(see data sheet A4.204.01)

CSR : CSR Coating (see data sheet A4.204.02)

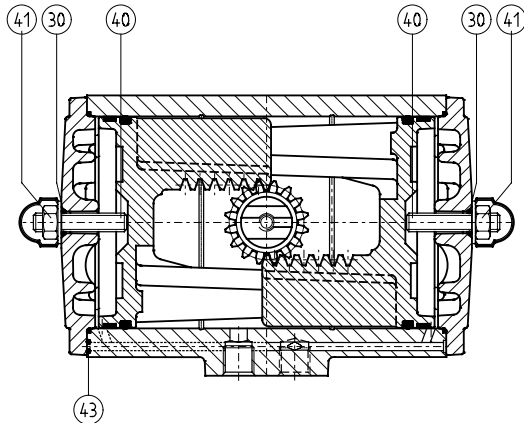

DOUBLE ACTING ED

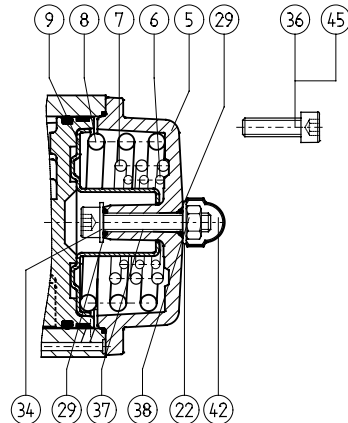

SINGLE ACTING ES

EL-O-MATIC™

www.El-O-matic.com

Copyright © Emerson Process Management. The information in this document is subject to change without notice.

Updated data sheets can be obtained from our website www.El-O-Matic.com or from your nearest Valve Automation Center **USA:** +1 813 319 0266 **Europe:** +31 74 256 10 10 **Asia-Pacific:** +65 6501 4600



EMERSON™
Process Management