

Data sheet

Sheet No.: 1.204.02 Rev. A
Date: November 2009

180° SPRING RETURN ACTUATOR TORQUE (Nm.)

180°

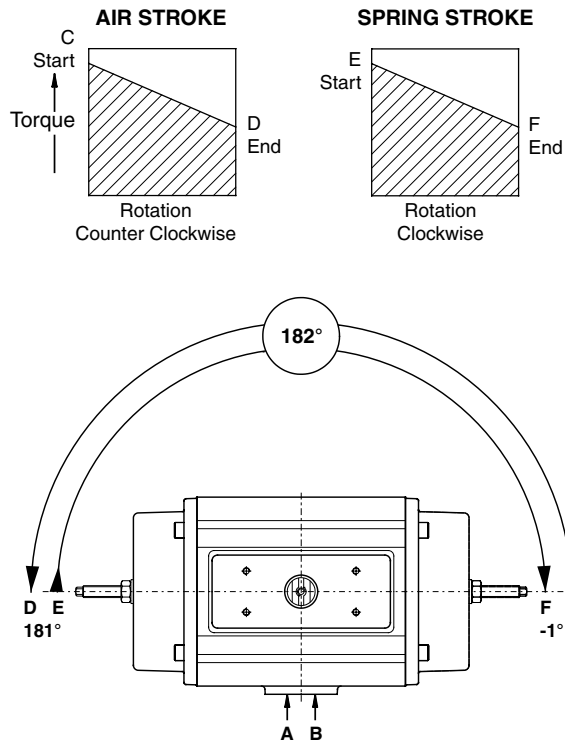

Note

- Emerson Process Management recommends that the valve manufacturer supply the maximum required torque values (Including any adjustments or suggested safety factors for valve service conditions or application).
Additionally, the valve manufacturer must identify at which position(s) and direction(s) of rotation (Counter Clock Wise or Clock Wise) these maximum requirements occur.
- If in doubt, or you require any assistance with sizing actuators, do not hesitate to contact your nearest Emerson's Valve Automation Division representative.
- Pressure on port "A" opens the actuator*
- The actuator is shown in closed position*
- Do not exceed the maximum supply pressure of 6 bar.
(*code A, data sheet 1.504)

Actuator type	Spring nr.	Air Stroke (Nm)														Spring Stroke (Nm)		
		SUPPLY PRESSURE																
		3		3.5		4		4.5		5		5.5		6		E	F	
ES 12	2	-	-	3.8	1.1	5.2	2.4	6.5	3.7	7.8	5.0	9.1	6.3	10.4	7.6	7.1	4.5	
	PE 60	8	9	4	12	6	15	9	18	12	21	15	24	18	27	21	13	7
		10	-	-	10	3	13	6	16	9	19	12	22	15	25	18	16	9
		12	-	-	-	-	11	3	14	5	17	8	20	11	23	14	19	11
PE 150	8	-	-	-	-	-	-	12	2	15	5	18	8	21	11	22	12	
	10	24	12	32	19	39	27	46	34	54	41	61	49	68	56	29	17	
	12	20	4	27	12	34	19	42	26	49	34	56	41	64	48	36	21	
	14	-	-	-	-	25	3	32	11	40	18	47	25	54	33	51	30	
PE 280	8	43	9	57	23	71	37	85	51	99	65	112	78	126	92	67	34	
	10	-	-	48	5	61	19	75	33	89	47	103	60	117	74	84	43	
	12	-	-	-	-	-	-	66	15	80	29	93	42	107	56	101	51	
	14	-	-	-	-	-	-	-	-	70	11	84	24	98	38	118	60	
PE 500	8	-	-	112	31	136	56	160	80	185	105	209	129	-	-	128	51	
	10	-	-	-	-	122	22	146	46	171	70	195	95	219	119	160	64	
	12	-	-	-	-	-	-	-	-	156	36	181	61	205	85	192	77	
	14	-	-	-	-	-	-	-	-	-	-	167	26	191	51	224	89	
PE 750	8	134	29	170	66	206	102	242	138	279	175	-	-	-	-	173	72	
	10	-	-	150	20	186	56	222	92	259	128	295	165	331	201	216	91	
	12	-	-	-	-	-	-	202	46	239	82	275	119	311	155	259	109	
	14	-	-	-	-	-	-	-	-	218	36	255	72	291	109	302	127	
PE1100	8	190	74	244	128	297	181	351	235	404	288	458	342	-	-	226	113	
	10	-	-	212	68	266	121	319	175	373	228	426	282	480	335	282	141	
	12	-	-	-	-	234	61	288	114	341	168	395	221	448	275	339	170	
	14	-	-	-	-	-	-	257	54	310	107	364	161	417	214	395	198	
PS2500	8	356	160	479	283	602	406	724	528	847	651	970	774	1093	897	528	332	
	10	-	-	387	142	510	265	632	387	755	510	878	633	1001	756	660	414	
	12	-	-	-	-	417	123	540	246	663	369	786	492	909	615	792	497	
	14	-	-	-	-	-	-	448	105	571	228	694	351	816	473	924	580	
PS4000	8	606	276	814	484	1023	692	1231	900	1439	1108	1647	1316	1855	1524	891	560	
	10	-	-	659	246	867	454	1075	662	1283	870	1492	1078	1700	1286	1114	699	
	12	-	-	-	-	712	216	920	424	1128	632	1336	840	1544	1048	1337	839	
	14	-	-	-	-	-	-	764	186	973	394	1181	602	1389	810	1560	979	



www.El-O-matic.com

Copyright © Emerson Process Management. The information in this document is subject to change without notice.

Updated data sheets can be obtained from our website www.El-O-Matic.com or from your nearest Valve Automation Center **USA:** +1 813 319 0266 **Europe:** +31 74 256 10 10 **Asia-Pacific:** +65 6501 4600



EMERSON
Process Management