

Data sheet

Sheet No.: 1.204.01 Rev. A

Date: November 2009

180° DOUBLE ACTING ACTUATOR TORQUE (Nm.)

180°

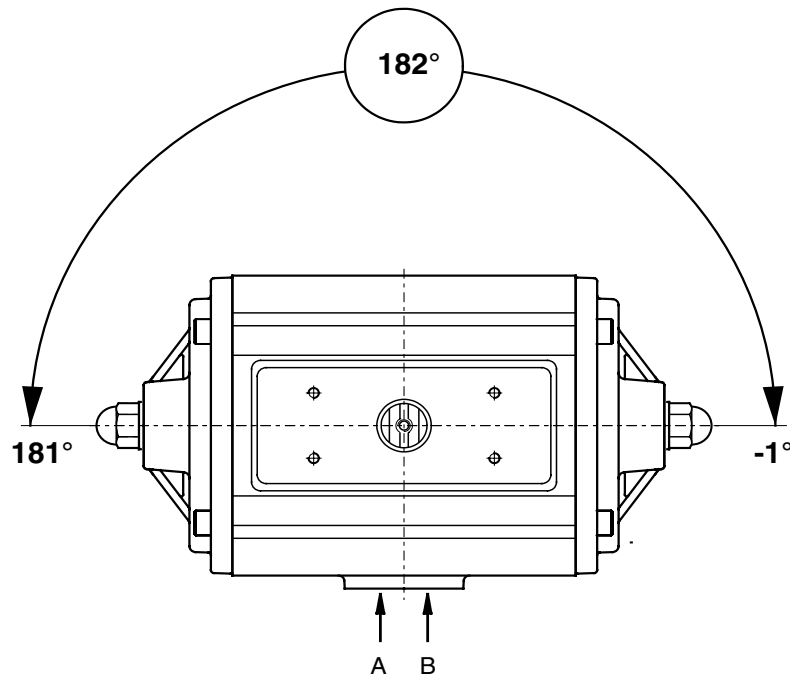
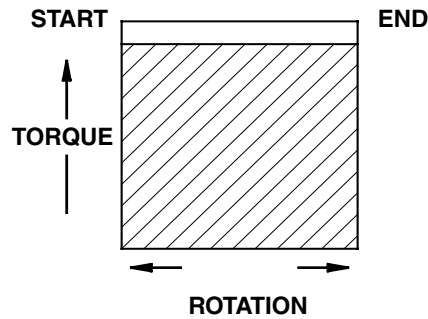

Actuator type	Torque in Nm Supply Pressure (bar)						
	2	3	4	4.5	5	5.5	6
ED 12	4.8	7.3	9.7	10.9	12.2	13.4	14.6
PD 60	11	17	23	26	29	32	35
PD 150	29	43	58	65	73	80	87
PD 280	54	81	109	123	137	150	164
PD 500	95	144	193	217	242	266	290
PD 750	142	214	287	323	359	395	432
PD 1100	209	316	423	476	530	583	637
PD 2500	481	728	974	1098	1221	1344	1468
PD 4000	812	1228	1645	1853	2061	2269	2477

Note

- Emerson Process Management recommends that the valve manufacturer supply the maximum required torque values (Including any adjustments or suggested safety factors for valve service conditions or application).
Additionally, the valve manufacturer must identify at which position(s) and direction(s) of rotation (Counter Clock Wise or Clock Wise) these maximum requirements occur.
- If in doubt, or you require any assistance with sizing actuators, do not hesitate to contact your nearest Emerson's Valve Automation Division representative.
- Pressure on port "A" opens the actuator*
- The actuator is shown in closed position*
- Do not exceed the maximum supply pressure of 6 bar.
(*code A, data sheet 1.503)

EL-O-MATIC™

www.El-O-matic.com

Copyright © Emerson Process Management. The information in this document is subject to change without notice.

Updated data sheets can be obtained from our website www.El-O-matic.com or from your nearest Valve Automation Center **USA:** +1 813 319 0266 **Europe:** +31 74 256 10 10 **Asia-Pacific:** +65 6501 4600



EMERSON™
Process Management