

Data sheet

Sheet No.: 1.103.073 Rev. B

Date: June 2010

DIMENSION SHEET STANDARD ACTUATOR - DIN

E/P

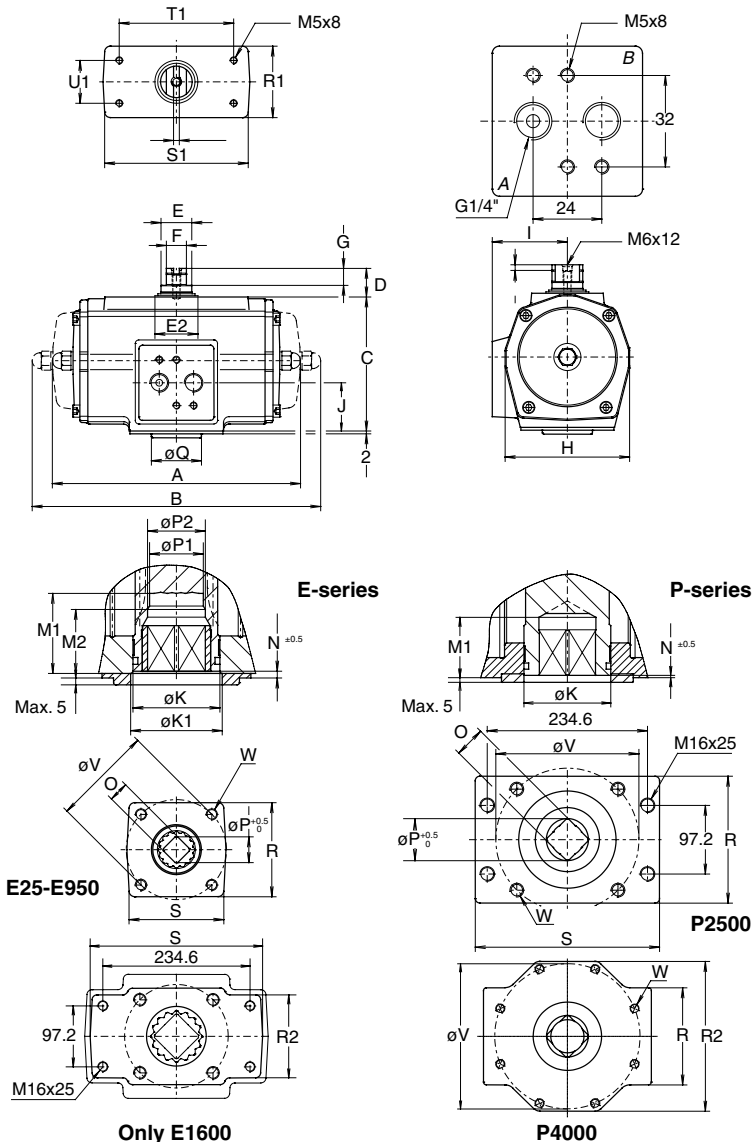

Dim. in mm.	Actuators E-series										P-series	
	E 12	E 25	E 40	E 65	E100	E150	E200	E 350	E600	E950	E1600	P2500
A DA	159	180	199	221	254	283	305	387	424	516	378	502
B SR	172	204	249	267	310	360	387	477	517	637	570	834
C	80	93	105	118	140	143	181	220	259	297	356	380
D	20	20	20	20	20	20	20	30	30	30	30	30
E	16	22	22	22	36	36	36	55	55	64	55	64
E2	23	30	30	30	45	45	45	65	65	75	65	80
F	10	14	14	14	19	19	19	36	36	36	36	36
G	12	12	12	12	12	12	12	10	10	10	10	10
H	74	86	98	108	121	128	173	207	231	265	350	380
I	46	53	58	63	70	73	95	113	126	142	183	200
J	32	34	40	45	59	51	73	84.5	105.5	120.5	178	190
K	24	33	33	38	55	55	55	68	75	95	85	120
K1	29	32	32	40	50	54	54	68	75	95	-	-
M1	34.5	34.5	34.5	34.5	50	50	50	52	64	82	66	77
M2	-	-	-	27	-	37	37	-	-	-	-	-
N	3	3	3	3.5	3.5	3.5	3.5	3.5	3.5	3.5	3	1.5
O max.	11.08	14.08	14.08	17.08	17.08	22.10	22.10	27.11	36.16	46.16	46.21	55.24
O min.	11.00	14.00	14.00	17.00	17.00	22.00	22.00	27.00	36.00	46.00	46.05	55.05
P	14.1	18.1	18.1	22.2	22.5	28.2	36.2	36.2	48.2	60.2	60.2	72.2
P1	14.1	18.1	21.1	23.1	28.5	32.1	32.1	36.5	48.5	60.5	-	-
P2	-	-	-	25.2	-	36.2	36.2	-	-	-	-	-
Q	35	35	35	55	55	70	70	85	100	130	130	200
R	52	65	70	70	86	90	114	124	130	154	170	170
R1	50	50	50	60	60	60	60	90	90	125	160	160
R2	-	-	-	-	-	-	-	-	-	132	-	262
S	52	65	70	70	92	90	114	124	142	280	290	290
S1	100	100	100	100	100	100	100	170	170	210	245	245
T1	80	80	80	80	80	80	80	130	130	130	130	130
U1	30	30	30	30	30	30	30	30	30	30	30	30
	F05	F05	F05	F07	F07	F10	F10	F12	F14	F16	F16	F25
V	50	50	50	70	70	102	102	125	140	165	165	254
W	M10 x 16	M10 x 16	M10 x 16	M8 x 13	M8 x 13	M10 x 16	M10 x 16	M12 x 20	M16 x 25	M20 x 30	M20 x 30	M16 x 25
Optional dimensions												
K1'	-	40	40	32	54	50	50	-	-	-	-	-
Q'	-	55	55	35	70	55	55	-	-	-	-	-
	F03	F07	F07	F05	F10	F07	F07	F10	F10	-	-	-
V'	36	70	70	50	102	70	70	102	102	-	-	-
W'	M5 x 8	M8 x 13	M8 x 13	M6 x 10	M10x16	M8 x 13	M8 x 13	M10x 16	M10 x 16	-	-	-

For E12 dimensions see data sheet 1.103.103

Note

1. Flange and square drive to DIN 3337
2. Top and solenoid flange to VDI/VDE 3845 (NAMUR)
3. For P-series actuators with limit stops see 1.501.01



www.El-O-matic.com

Copyright © Emerson Process Management. The information in this document is subject to change without notice.

Updated data sheets can be obtained from our website www.El-O-matic.com or from your nearest Valve Automation Center **USA**: +1 813 319 0266 **Europe**: +31 74 256 10 10 **Asia-Pacific**: +65 6501 4600



EMERSON
Process Management