

Data sheet

Sheet No.: 1.102 Rev. B
Date: January 2012

TECHNICAL DETAILS, STANDARD ACTUATOR

E/P

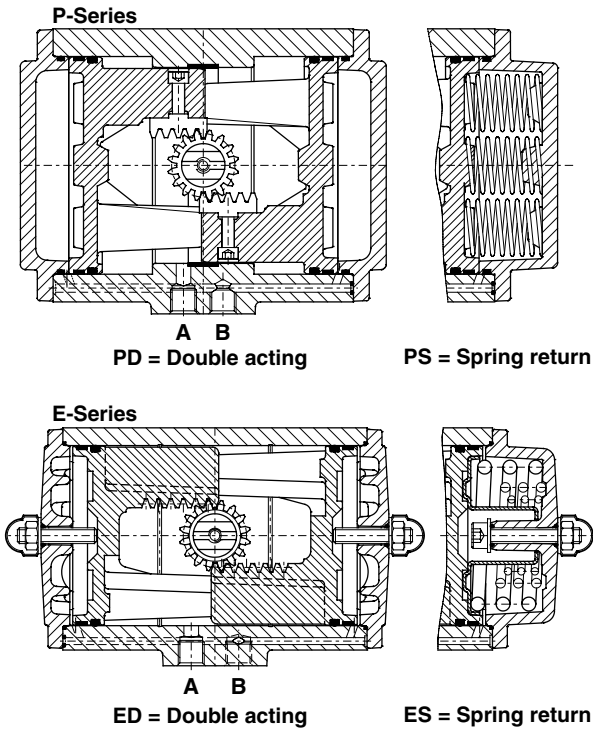

Specification

Pressure range : Double acting 0.2 to 8 bar
: Spring return 6 to 8 bar, with max. spring set
: 3 to 8 bar, reduced spring quantity

Torque : 180° actuators 6 bar g maximum
: 14.6 to 4955 Nm at 6 bar supply
See torque data sheets 1.104.01 and 1.104.02

Operating media : Air, dry or lubricated and inert gasses
: For sub-zero applications take appropriate measures

Temperature : -20° to +80°C

Lubrication : Factory lubricated for the normal life of the actuator

Construction : Suitable for indoor and outdoor installation

Finish : Polyester non-TGIC based powder coating
(see data sheet 4.204.01)

Rotation : 91.5° (-0.5° CW to 91° CCW)

Double acting : Standard counter clockwise with port "A" pressurized
(code A, see data sheet 1.503 for other assembly codes)

Spring return : Clockwise fail action
(code A, see data sheet 1.504 for other assembly codes)

Limit stops : Standard on E-Series. Adjustable range 91°/80°
: Optional on P-Series. See data sheet 1.501.01
: For double stroke adjustment. See data sheet 1.501.05

European Directives

PED : All actuators are suitable for use with Group 2 gasses according to Pressure Equipment Directive 97/23/EC
: Optional : actuators suitable for use with Group 1 gasses

ATEX : All basic actuators are suitable for use in hazardous area's classified II 2 GD, zones 1 or 2 (Gasses) and 21 or 22 (Dust)

Russian Approvals

EI-O-Matic E and P series pneumatic actuators are available with the GOST-R and Rostechnadzor (RTN) approvals.

Note

1. Operating time is average with actuator under load and solenoid valve fitted.
2. Air consumption is the actual free air volume at 1 atm.
3. Pressure is in barg.

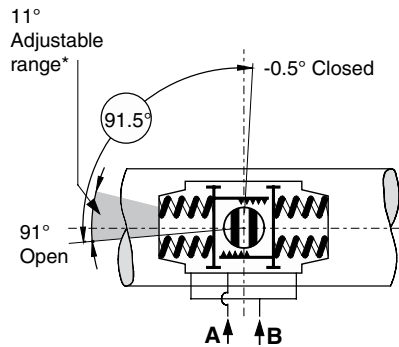

* only standard on E-Series actuators

ACTUATOR TYPE		E12	E25	E40	E65	E100	E150	E200	E350	E600	E950	E1600	P2500	P4000
Bore	mm.	46	56	70	80	91	103	110	145	175	200	230	300	325
Stroke	mm.	12.6	15.7	18.8	22	25.1	31.4	37.7	37.7	44	50.3	62.8	56.5	81.7
Weight:	Double acting	kg.	0.6	1.3	1.8	2.4	3.1	4.8	5.8	10.4	19.4	26.4	42.7	56.8
	Spring return	kg.	0.7	1.7	2.4	3.6	4.6	6.9	9.1	16.9	27.6	38.6	65.8	88.2
Operating time	sec.	0.4	0.5	0.7	1.1	1.2	1.8	2.3	3.6	4.5	5.4	6.9	7	12
Air consumption at 1 atm (litres)	port A	stroke	0.1	0.1	0.2	0.3	0.4	0.73	0.8	1.8	2.9	4.7	7.3	8
	port B	stroke	0.1	0.1	0.2	0.4	0.5	0.65	1	1.9	3.1	4.9	8.0	9.3

EL-O-MATIC

www.El-O-matic.com

Copyright © Emerson Process Management. The information in this document is subject to change without notice.

Updated data sheets can be obtained from our website www.El-O-Matic.com or from your nearest Valve Automation Center **USA:** +1 813 319 0266 **Europe:** +31 74 256 10 10 **Asia-Pacific:** +65 6501 4600



EMERSON
Process Management