

Data sheet

Sheet No.: 1.101.70 Rev. D

Date: January 2012

LOW TEMPERATURE ACTUATOR SPECIFICATIONS

-40°C / +80°C

-40°F / +176°F

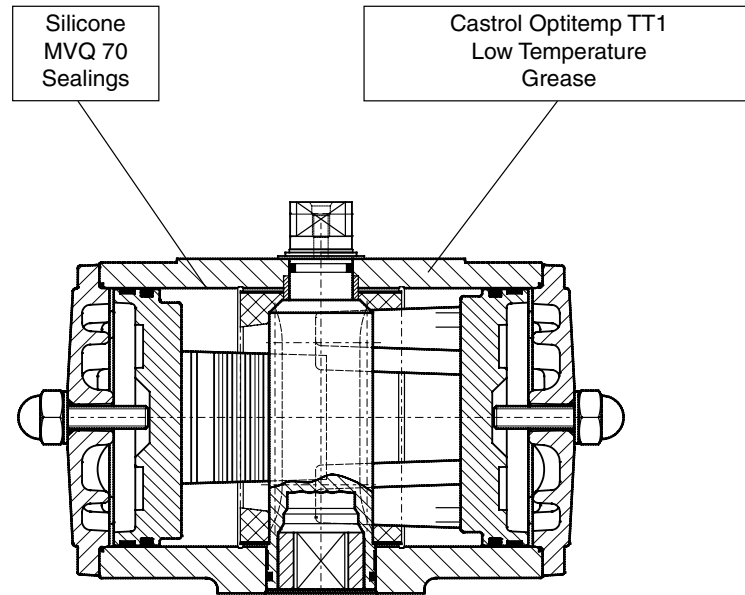

Description

A double piston, rack and pinion pneumatic actuator incorporating a three point piston support system, anti-blowout spindle and with high duty synthetic bearings at all bearing points.

This version is a standard aluminium actuator, but incorporating parts and materials suitable for low temperature operation.

Note

When operating actuators in sub-zero temperatures (< 0°C or < 32°F) care should be taken to counter the effects of freezing condensate inside the actuator.

Specification

Max. pressure : 8 bar (120 psi)

Torque : Standard

Media : Air or non corrosive gas

Temperature : -40°C to +80°C (-40°F to +176°F)

Finish : Polyester non-TGIC based powder coating (see data sheet 4.204.01)

Spare parts

Dedicated low temperature spare parts are available for maintenance or make a standard actuator suitable for low temperature operation.

Materials				
Part	Material		Specifications	Remark
Housing	Aluminium Alloy		GAISi10Mg, DIN 1725/2	
Drive Shaft	Aluminium Alloy		AlZnMgCu1.5, DIN 1725/1	Hard anodised
	Steel (180° rotation)		ETG100 or 42CrMo4V XM	Zinc Plated type > P750
	Stainless Steel		Sandvic 1802, SS2382 or X35CrM017	type > E950
Piston	Aluminium Alloy		GAISi 7Mg, DIN 1725/2	
Sealings	Silicone MVQ 70 O-rings		-/-	
Grease	Castrol Optitemp TT1		-/-	
Shaft bearings	Top :	Delrin	POM	
	Bottom :	Nylatron	PA6.6 + MoS2	
Piston bearings	PTFE		25% Carbon filled	
Body bearings	PTFE	("P" series)	25% Carbon filled	
	Nylatron	("E" series)	PA6.6 + MoS2	
Shaft thrust washer	ZEDEX 100 K		-/-	
End cap bolts	Stainless Steel	("E" series)	AISI 304 A2	
	Alloy Steel	("P" series)	8.8 DIN 912	Deltatone® coating
Springs	Carbon Spring Steel		Class C, DIN17223	Deltatone® coating

EL-O-MATIC™

www.El-O-matic.com

Copyright © Emerson Process Management. The information in this document is subject to change without notice.

Updated data sheets can be obtained from our website www.El-O-Matic.com or from your nearest Valve Automation Center **USA:** +1 813 319 0266 **Europe:** +31 74 256 10 10 **Asia-Pacific:** +65 6501 4600



EMERSON™
Process Management