

Data sheet

Sheet No.: 1.101.60 Rev. B

Date: January 2012

CONSTRUCTION, PARTS AND MATERIALS DSA ACTUATOR

DSA

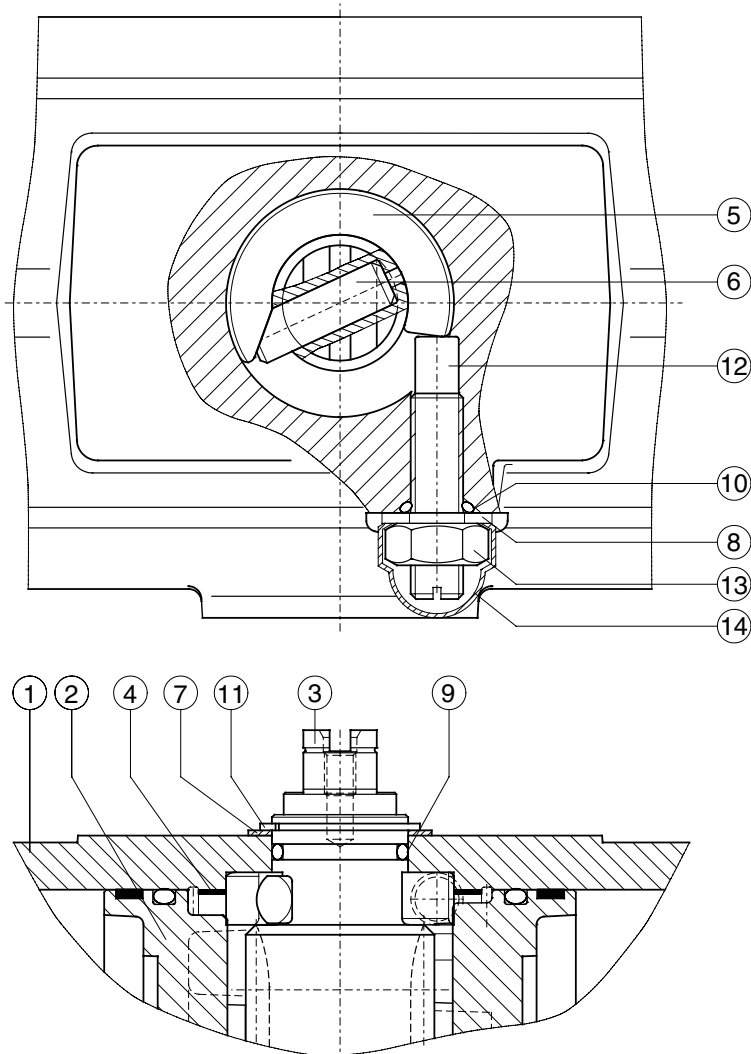

Nr.	Description	Qty.	Material	Specification	Note
1	Body DSA	1	Aluminium Alloy	GAISI10Mg, DIN 1725/2	-
2	Piston DSA	2	Aluminium Alloy	GAISI 7Mg, DIN 1725/2	-
3	Drive Shaft DSA	1	Aluminium Alloy	AlZnMgCu1.5, DIN 1725/1	1
4	* Guide Band DSA	1	Nylatron GS	PA6.6 + MoS2	-
5	Cam for stroke adj. DSA	1	Stainless Steel	AISI 304	-
6	Shaftpin for stroke adj. DSA	1	Chrome nickel steel	30CrNiMo8	-
7	* Washer	1	ZEDEX 100 K	-	-
8	* Washer	1	Nylon	PA6	-
9	* O-ring shaft top	1	Nitrile Rubber	Buna N	-
10	* O-ring limit stop bolt DSA	1	Nitrile Rubber	Buna N	-
11	Circlip	1	Carbon spring steel	Ck75, DIN17222	2
12	Limitstop bolt DSA	1	Stainless Steel	AISI 304	-
13	Nut	1	Stainless Steel	AISI 304	-
14	Nut Cover	1	Polyethylene	PE	-

* Recommended spare parts (contained in Repair kits DSA)

Finish

Polyester non-TGIC based powder coating (see data sheet 4.204.01)

Note

- 1 Hard anodised
- 2 Deltatone® coating

Remark

This data sheet shows only the extra or specific parts of a DSA actuator.
For all the other parts see data sheet 1.101.33

EL-O-MATIC™

www.El-O-matic.com

Copyright © Emerson Process Management. The information in this document is subject to change without notice.

Updated data sheets can be obtained from our website www.El-O-Matic.com or from your nearest Valve Automation Center **USA:** +1 813 319 0266 **Europe:** +31 74 256 10 10 **Asia-Pacific:** +65 6501 4600



EMERSON™
Process Management