

P-Series - Double acting

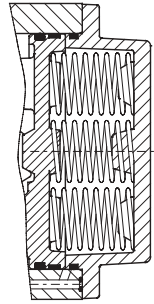

Spring return

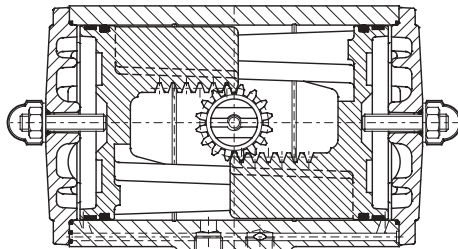

E-Series - Double acting

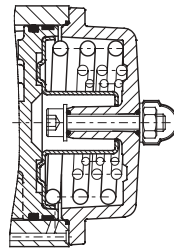

Spring return

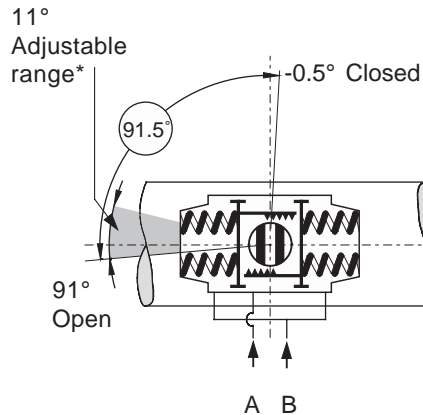

* only standard on E-Series actuators

Specification:

Pressure range : Double acting 20 to 120 psi.
: Spring return 80 to 120 psi, with max. spring set.
40 to 120 psi, reduced spring set.

Torque : 133 to 40,000 in.lb at 80 psi supply.
(see torque data sheets A1.104.01 and A1.104.02).

Operating media : Air, dry or lubricated or non-corrosive gas.

Temperature : -4° to +175°F

Lubrication : Factory lubricated for the normal life of the actuator.

Construction : Suitable for indoor and outdoor installation.

Finish : Two component polyurethane coating, see A4.204.01.

Rotation : 91.5° (-0.5° cw to 91° ccw)

Double acting : Standard counter clockwise with port "A" pressurized
(code A, see data sheet A1.503 for other assembly codes).

Spring return : Clockwise fail action
(code A, see data sheet A1.504 for other assembly codes).

Limit stops : Standard on E-series. Adjustable range 91°/80°
: Optional on P-series. See data sheet A1.501.01
: For double stroke adjustment. See data sheet A1.501.05

European Directives

PED : All actuators are suitable for use with Group 2 gasses according to Pressure Equipement Directive 97/23/EC.
: Optional : actuators suitable for use with Group 1 gasses.

ATEX : All basic actuators are suitable for use in hazardous area's classified II 2 GD, zones 1 or 2 (Gasses) and 21 or 22 (Dust).

Note:

1. Operating time is average with actuator under load and solenoid valve fitted.
2. Air consumption is the actual free air volume at 1 atm.
3. Pressure is in psi.
4. ED or PD = Double acting.
ES or PS = Single acting.

ACTUATOR TYPE		E12	E25	E40	E65	E100	E200	E350	E600	E950	E1600	P2500	P4000	
Bore	inch	1,8	2,2	2,8	3,1	3,6	4,3	5,7	6,9	7,9	9,1	11,8	12,8	
	Stroke	inch	0,5	0,6	0,7	0,9	1,0	1,5	1,5	1,7	2,0	2,2	3,2	
Weight:	Double acting	lb.	1,3	2,9	4,0	5,3	6,8	12,8	22,9	42,8	58,2	94,1	125	191
	Spring return	lb.	1,5	3,7	5,3	7,9	10,1	20,1	37,3	60,8	85,1	145,1	194	291
Operating time		sec.	0,4	0,5	0,7	1,1	1,2	2,3	3,6	4,5	5,4	6,9	7	12
Air consumption at 1 atm (cu./in.)	port A	stroke	3,1	6,1	9,8	20,1	21,4	49	110	177	287	445	488	824
	port B	stroke	3,7	6,7	13,4	22,0	29,9	61	116	189	299	488	568	1.068