

Subject to change without notice

VALVE AUTOMATION SYSTEMS

EL-O-MATIC<sup>®</sup>  
w w w . e l - o - m a t i c . c o m

Nr.:  
1.103.106  
All rights reserved

Date:  
March '04

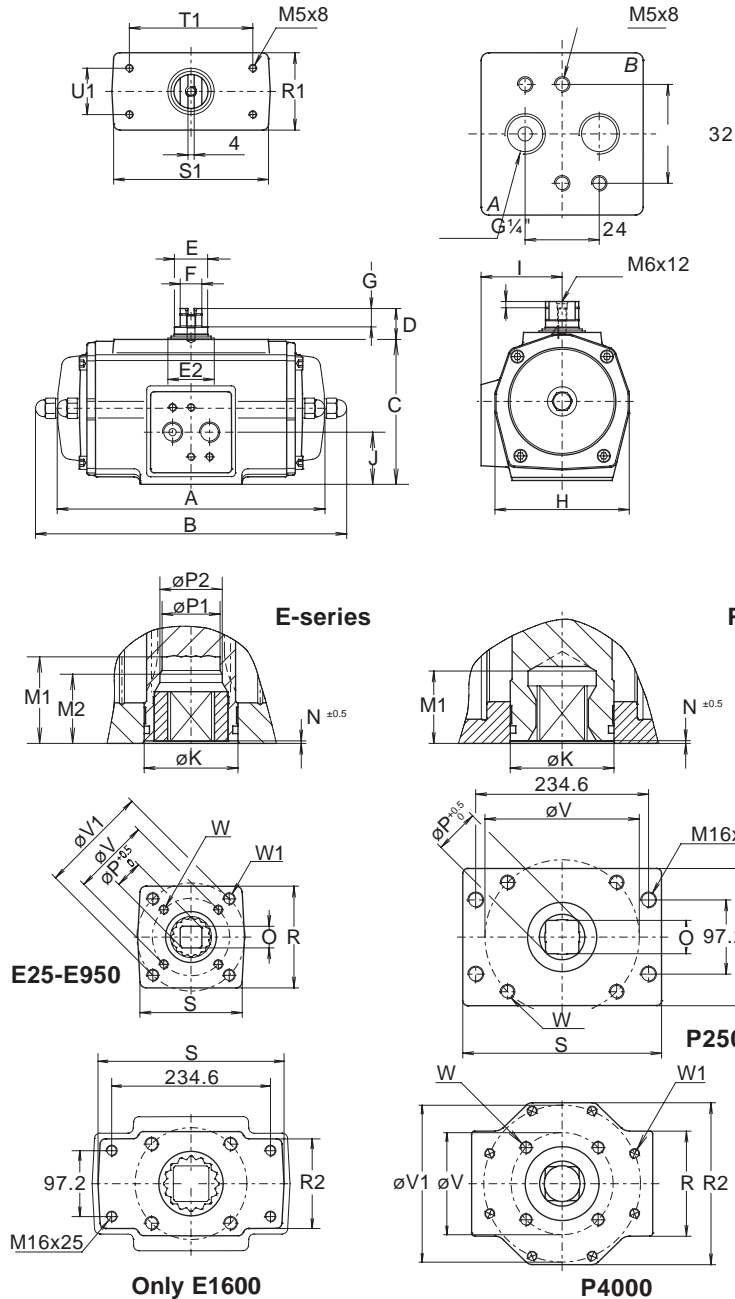

Dim. in mm.	Actuators E-series										P-series	
	E 12	E 25	E 40	E 65	E100	E200	E 350	E600	E950	E1600	P2500	P4000
A DA	159	180	199	221	283	305	387	424	516	378	502	
B SR	172	204	249	267	360	387	477	517	637	570	834	
C	80	93	105	118	143	181	220	259	297	356	380	
D	20	20	20	20	20	20	30	30	30	30	30	
E	16	22	22	22	36	36	55	55	64	55	64	
E2	23	30	30	30	45	45	65	65	75	65	80	
F	10	14	14	14	19	19	36	36	36	36	36	
G	12	12	12	12	12	12	10	10	10	10	10	
H	74	86	98	108	128	173	207	231	265	350	380	
I	46	53	58	63	73	95	113	126	142	183	200	
J	32	34	40	45	51	73	84,5	105,5	120,5	178	190	
K	24	33	33	38	55	55	68	75	95	85	120	
M1	34,5	34,5	34,5	34,5	50	50	52	64	82	66	77	
M2	-	-	-	27	37	37	-	-	-	-	-	
N	1	1	1	1,5	1,5	1,5	1,5	1,5	1,5	3	1,5	
O max.	11,11	14,11	14,11	19,13	22,13	27,13	27,13	36,16	46,16	46,16	55,19	
O min.	11,00	14,00	14,00	19,00	22,00	27,00	27,00	36,00	46,00	46,00	55,00	
P	14,1	18,1	18,1	25,2	28,2	36,2	36,2	48,2	60,2	60,2	72,2	
P1	14,1	18,1	21,1	23,1	32,1	32,1	36,5	48,5	60,5	-	-	
P2	-	-	-	25,2	36,2	36,2	-	-	-	-	-	
R	52	65	70	70	90	114	124	130	154	170	170	
R1	50	50	50	60	60	60	90	90	125	160	160	
R2	-	-	-	-	-	-	-	-	132	-	262	
S	52	65	70	70	90	114	124	142	280	290	290	
S1	100	100	100	100	100	100	170	170	210	245	245	
T	-	-	-	-	-	-	-	-	234,6	234,6	-	
T1	80	80	80	80	80	80	130	130	130	130	130	
U	-	-	-	-	-	-	-	-	97,2	97,2	-	
U1	30	30	30	30	30	30	30	30	30	30	30	
F03	F05	F05	F05	F05	F07	F07	F10	F10	F16	F16	F16	
V	36	50	50	50	70	70	102	102	165	165	165	
W	M5x8	M6x10	M6x10	M6x10	M8x13	M8x13	M10x16	M10x16	M20x30	M20x30	M20x30	
V1	F05	F07	F07	F07	F10	F10	F12	F14	-	-	F25	
W1	50	70	70	70	102	102	125	140	-	-	254	
W2	M6x10	M8x13	M8x13	M8x13	M10x16	M10x16	M12x20	M16x25	-	-	M16x25	
	-	-	-	-	-	-	-	-	M16x25	M16x25	-	

For E12 dimensions see data sheet 1.103.102

- Note:
1. Flange and square drive to ISO 5211
  2. Top and solenoid flange to VDI/VDE 3845 (NAMUR)
  3. For P-series actuators with limit stops see 1.501.01

DIMENSION SHEET STANDARD ACTUATOR - ISO -

E/P