

Subject to change without notice

VALVE AUTOMATION SYSTEMS

ELCO-MATIC<sup>®</sup>  
www.elco-matic.com

Nr.:  
1.103.102  
All rights reserved

Date:  
March '96

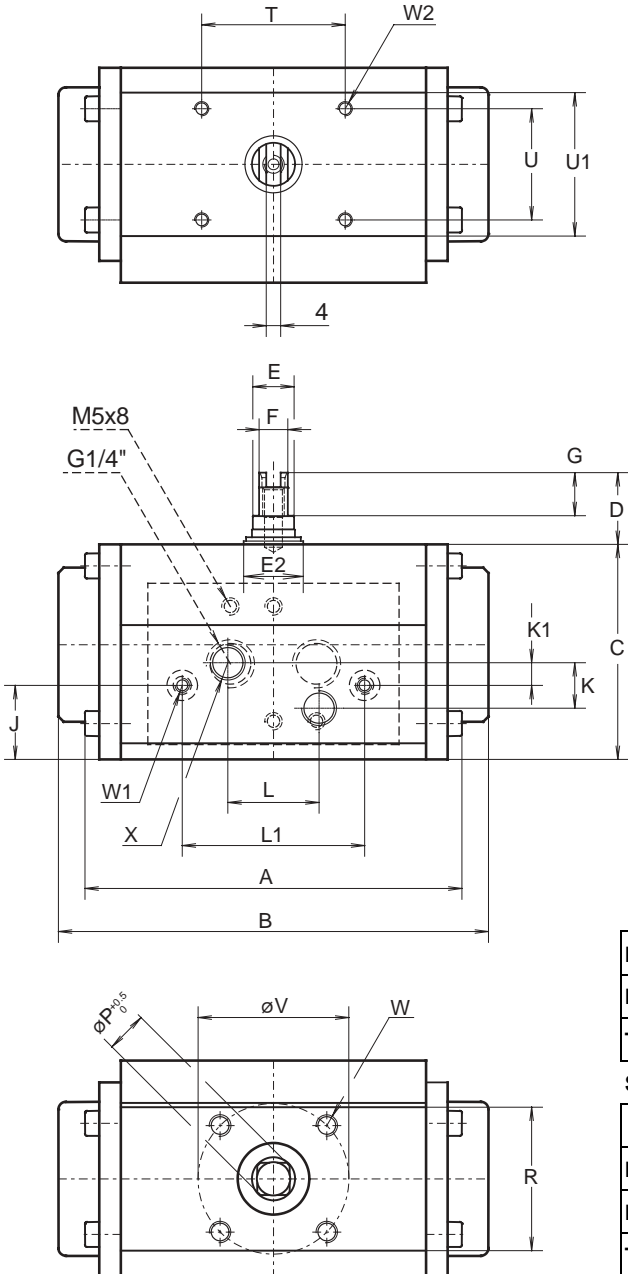

**Note:** Dotted image represents optional NAMUR solenoid interface block

DOUBLE ACTING TORQUE (ED)								
Pressure	bar	3.5	4	4.5	5	5.5	6	7
Torque 90°/180°	Nm	8.5	9.7	10.9	12.2	13.4	14.6	17.1

SINGLE ACTING TORQUE (ES)							
		Air stroke				Spring stroke	
Pressure	bar	5		6			
Position	-	start	end	start	end	start	end
Torque 90°	Nm	7.6	4.9	10	7.5	7.2	4.6
Torque 180°	Nm	7.8	5	10.4	7.6	7.1	4.5

DIM. (mm.)	90°	180°
A ED	103	155
B ES	118	216
C	60	60
D	20	20
E	16	16
E2	23	23
F	10	10
G	12	12
H	60	60
I	33	33
J	21	21
K	12.7	12.7
K1	6.35	6.35
L	25.4	25.4
L1	50.8	50.8
M	16.5	16.5
N	1	1
O MAX	9.09	9.09
O MIN	9.00	9.00
P	12.1	12.1
R	40	40
R1	40	40
T	40	40
U	31	31
V	42	42
W	M6x8	M6x8
W1	M4x7	M4x7
W2	M4x7	M4x7
X	G1/8"	G1/8"
Y	M6x12	M6x12

DIMENSION SHEET ACTUATOR ISO

E12 (90°/180°)