

Subject to change without notice

VALVE AUTOMATION SYSTEMS

EL-O-MATIC®  
WWW.EL-O-MATIC.COM

Nr.: 3-120  
All rights reserved

Date: May '04

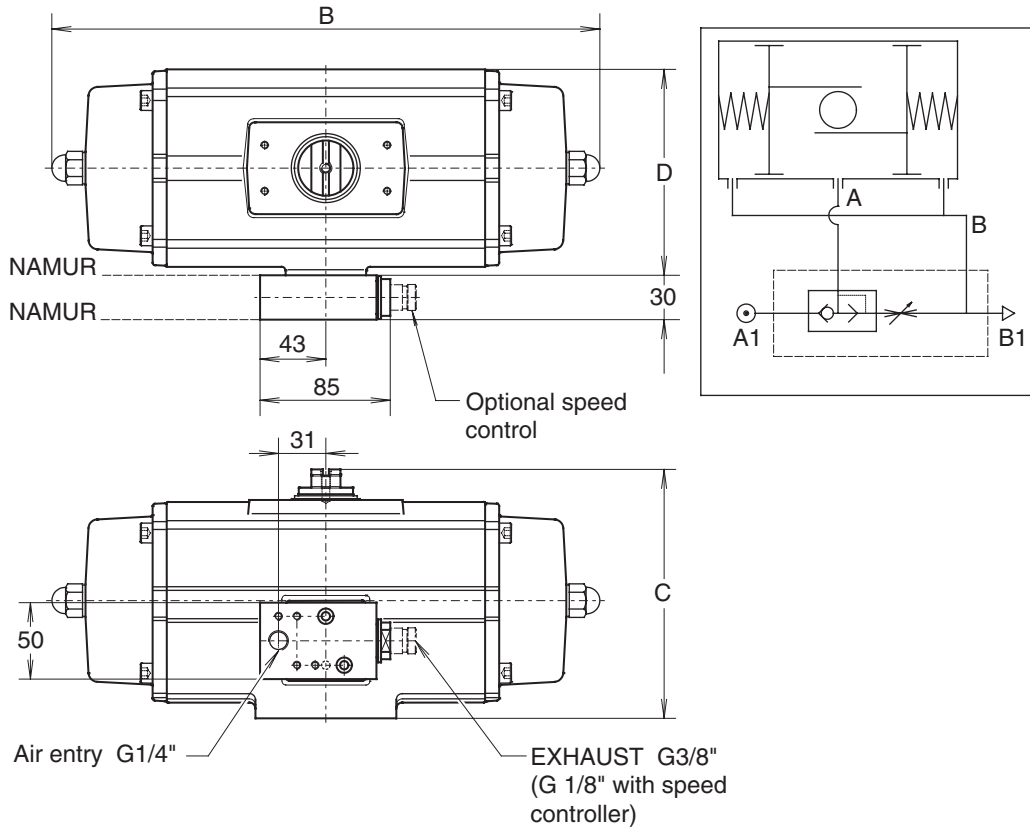

**Description:**

The breather block provides corrosion protection of the actuator spring chamber. It should be used on applications where the actuator is located in a corrosive atmosphere which would otherwise be sucked into the actuator through the "B" port during the spring stroke.

The breather block is fixed directly onto the NAMUR air entry manifold and has a further NAMUR interface so that a suitable solenoid valve may be directly mounted, or for a tubing connection in the case of a remote solenoid valve.

The breather block has an built-in quick exhaust function to improve the spring stroke time (see table). An optional speed control can be provided to regulate this closing time.

**Operation:**

Air entering the actuator at A1 moves the shuttle valve to the right and allows the actuator to operate normally, displaced air from "B" is exhausted through "B1".

At the spring stroke, air is exhausted at "A1" and the shuttle valve moves to the left allowing the air from "A" to first fill the spring chamber through "B" then to exhaust to atmosphere at "B1".

**General Specification:**

- Housing : Aluminium alloy
- Finish : Hard anodized, impregnated with PTFE
- Pressure : 1 to 8 bar
- Media : Air, dry or lubricated or non-corrosive gas (not suitable for oxygen service)
- Temperature : -20° to 80°C
- Air entry : G 1/4"
- Air exhaust : G 3/8" ( or 1/8" with speed control)
- Air flow (Kv) : Air stroke : 0.8 (m³/h)  
: Spring stroke : 1.9 (m³/h)

**Identification:**

- Factory option : "BB" is added to the basic actuator part Nr. eg. ES200+BB
- Kit option : Kit BB
- With speed control : Kit BBS

Dimensions in mm.	Actuator type										
	E25	E40	E65	E100	E200	E350	E600	E950	E1600	P2500	P4000
<b>B PE/ES</b>	172	204	249	267	360	387	477	517	637	570	834
<b>C</b>	100	113	125	138	163	201	250	289	327	386	410
<b>D</b>	83	96	107	117	137	182	217	242	275	358	390
<b>Operating times in sec. (at 6 bar with average load)</b>											
<b>Air stroke</b>	0.35	0.40	0.50	0.53	0.78	1.1	1.7	2.6	4.1	4.7	8.6
<b>Spring stroke</b>	0.33	0.36	0.42	0.44	0.58	0.80	1.1	1.7	2.6	2.9	5.3

SPRING RETURN ACTUATOR WITH Q.E. BREATHER BLOCK

BB