

Subject to change without notice

VALVE AUTOMATION
SYSTEMS

EL-O-MATIC®
WWW.EL-O-MATIC.COM

All rights reserved

Nr.:

A 5.302

Date:

Febr. '00

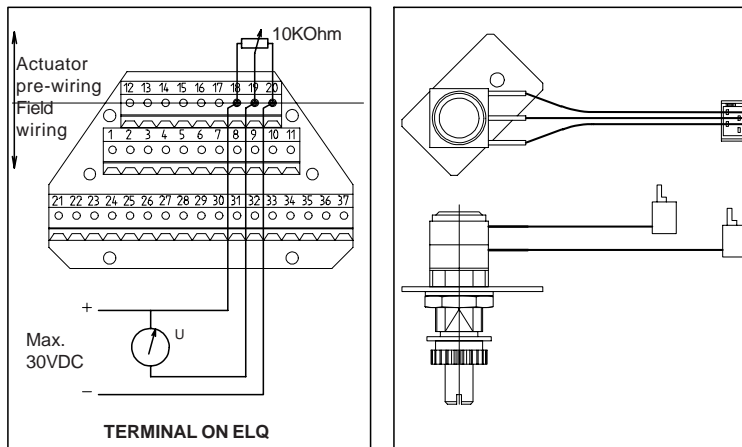
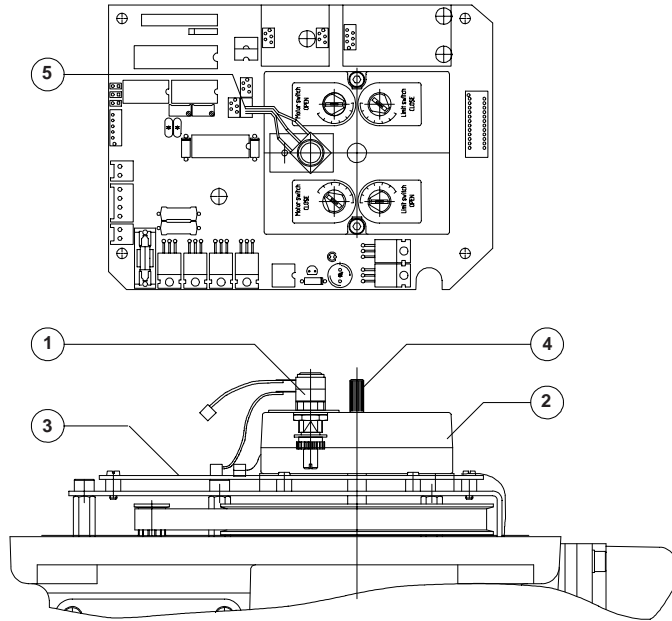

Description:

This ELQ electric actuator option provides a varying indication of the actuator and valve position by means of an electrical potentiometer. When connected as shown a voltage signal will indicate an analog position.

Construction:

The potentiometer (1) is mounted in the limit switch assembly (2) on top of the mainboard (3). The potentiometer is driven by the indicator shaft (4) and an intermediate gear in the limit switch assembly. The potentiometer connector (5) is plugged in the mainboard. The mainboard is prewired to the terminal strip in the terminal compartment.

Specifications:

Voltage : Up to 30VDC
 Current : 15 mA max.
 Power max. : 0.5 W
 Temperature : -4.0° to +158°F
 Resistance : 10KΩ; (see variations)
 Type : PA11
 Linearity : 1 %
 Mechanical rotation : 300° ±5°
 Electrical rotation : 270° ±10°

Identification:

Factory option : Add "+ Q-POT" to the basic actuator size.
 : eg. ELQ100 + Q-POT.
 Kit option : Actuator size is added to: "Kit Q-POT".
 : eg. Kit Q-POT / ELQ100.

Variations:
 1KΩ to 470KΩ

Note 1) When a combination of two options is needed, both of which need a feedback potentiometer, the second plug from the double potentiometer can be used.

ELQ ACTUATOR WITH POTENTIOMETER

Q-POT