

Data sheet

Sheet No.: 5.307 Rev. A

Date: November 2009

ELQ ACTUATOR WITH LOCAL CONTROL STATION

Q-LC

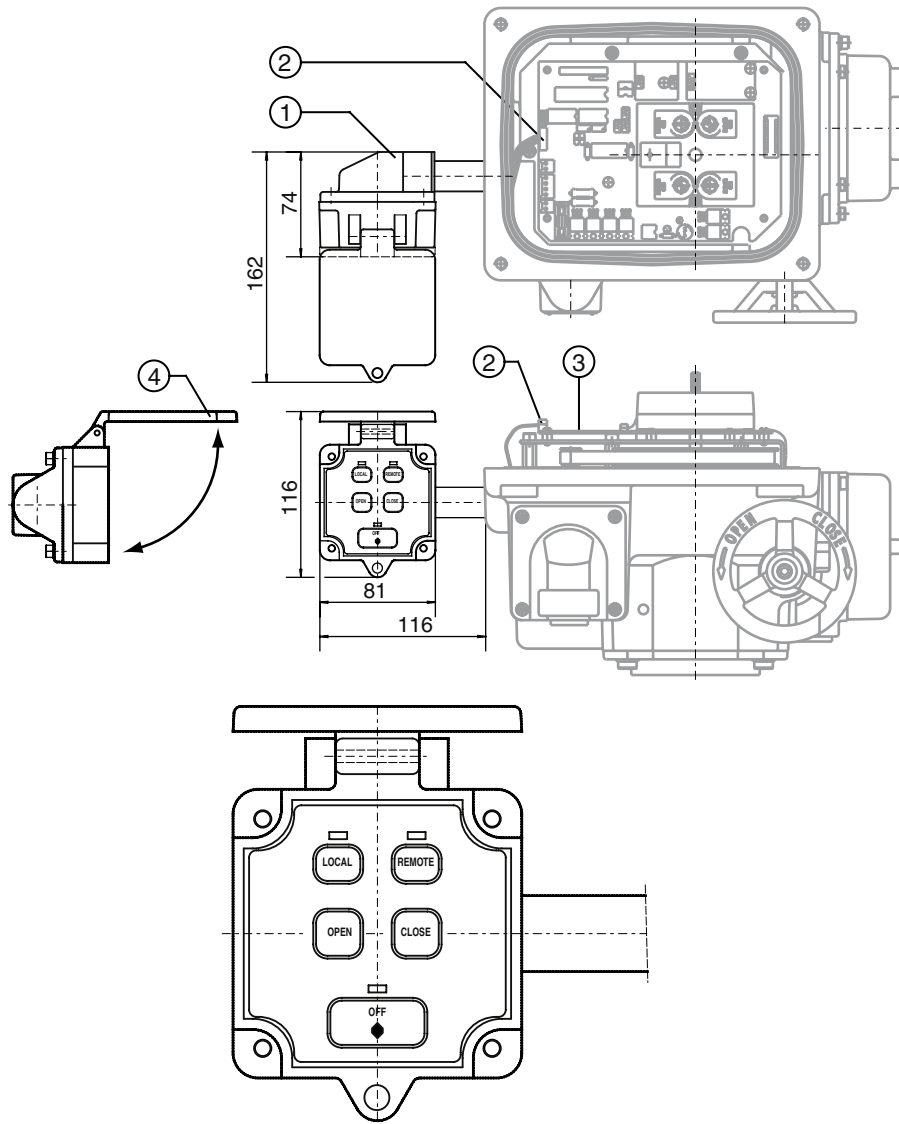

Description

This ELQ electric actuator option provides a local control box. The box is equipped with buttons for "Local", "Remote", "Open" and "Closed". LED's indicate the "Local", "Remote" or the "Off" status.

When "LOCAL" is selected the valve may be moved to the "Open" or "Closed" position by pressing the "Open" or "Closed" button.

The "Open" and "Closed" buttons are locked out when "Remote" is selected and the control is returned to the remote control station.

The optional status module (see data sheet 5.308) can give a signal to the control room indicating that the ELQ-actuator is switched to local control.

Construction

The control box (1) is located on the side of the actuator casting. All the connection wiring is contained internally. The connector (2) is plugged in on top of the mainboard (3). The cover (4) may be locked by an optional pad lock.

Specification

| | | |
|-------------|-------------|------------------------------|
| Switches | Temperature | : -20°C to +70°C |
| Housing | Material | : Aluminum |
| | Finish | : Two component polyurethane |
| Enclosure | | : IP67 |
| Steel parts | | : Stainless steel |

Identification

| | |
|----------------|---|
| Factory Option | : Add "+ Q-LC" to the basic actuator size |
| | : eg. ELQ100 + Q-LC |
| Kit Option | : Actuator size is added to: "Kit, Q-LC" |
| | : eg. Kit, Q-LC/ELQ100 |

Variations

Local control box with pad lock

EL-O-MATIC

www.El-O-matic.com

Copyright © Emerson Process Management. The information in this document is subject to change without notice.

Updated data sheets can be obtained from our website www.El-O-matic.com or from your nearest Valve Automation Center **USA:** +1 813 319 0266 **Europe:** +31 74 256 10 10 **Asia-Pacific:** +65 6501 4600



EMERSON
Process Management