

Installation Instructions Positioners Series II

Read these instructions completely before attempting to install calibrate or troubleshoot the positioner.

* **Before starting check the kit to ensure that all parts are available and the MOD card control signal is the same as required for the application.**

* **There are two versions (See fig 5):**

1. 4-20mA Control signal
2. 0-10V Control signal

Pos	Qty	Description	Used on EL:	
			55	100-1600
3	1	Drive pinion (large)	*	*
4	1	Potentiometer pinion (small)	*	*
5	1	Potentiometer spacer	*	*
6	1	Potentiometer 10K	*	*
9	3	Print spacer	*	*
9	3	Spacer/screw		*
16	1	Positioner card	*	*

Mechanical Installation.

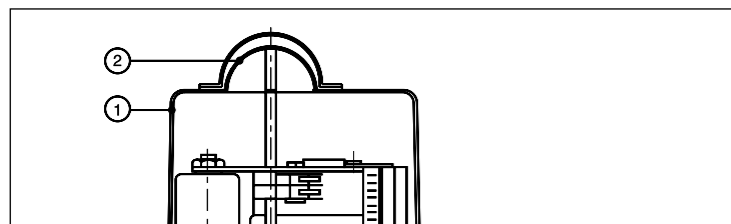

Fig. 1 Remove actuator cover (1) and dial (2).

1. Remove actuator cover (1) and dial (2).
2. Mount potmeter (6) on motor top plate using lock nut and spacer (5).
3. Slide potmeter pinion (small pinion, 4) over potmeter-shaft and tighten screw.
4. Slide drive pinion (large pinion, 3) over indicator shaft.
5. Ensure that end of travel limit switches have been set correctly.
For direct action: Set the actuator in the close position. Turn the potentiometer fully CCW and then about 20° CW then tighten drive pinion fixing screw.
For reverse action: Set the actuator in the open position. Turn the potentiometer fully CW and then about 20° CCW then tighten drive pinion fixing screw.

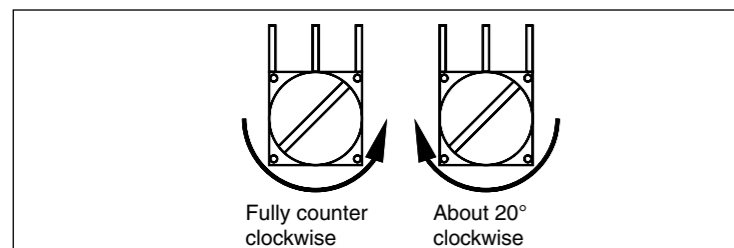

Fig. 2 Potentiometer setting

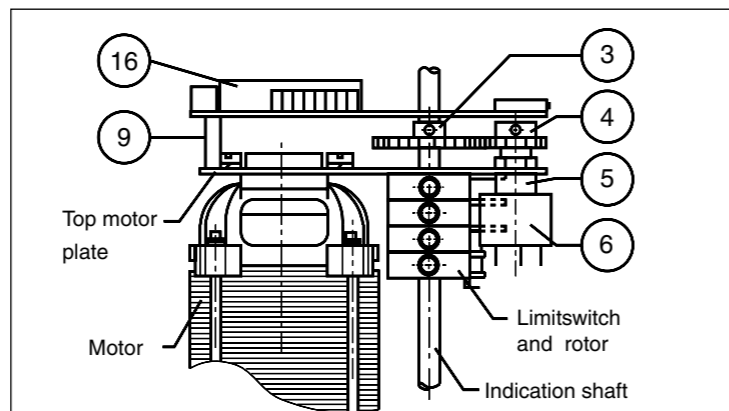

Fig. 3 MOD board assembly

6a. For EL35/55 only;

Insert three print spacers (9) into motor top plate and place positioner board over indicator shaft so that 3 spacers locate correctly into three holes in circuit board. Now press into place.

6b. For EL100 up to EL1600;

Place positioner board over indicator shaft and mount to motor top plate using 3 screws and plastic spacers (9) (the screws engage with 3 nuts welded to top motor plate).

Electrical Installation.

7. Connect three potentiometer leads to positioner terminals:

For direct action:	19-Blue	20-Black	21-Yellow.
For reverse action:	19-Yellow	20-Black	21-Blue.

8. **1 phase:** Remove links from 2-10 and 3-7.
3 phase: Disconnect 7 and 10 from the contactors.
9. **IMPORTANT!** Check or set the voltage switch, on the positioner board, to the actual power supply voltage (see fig 4).

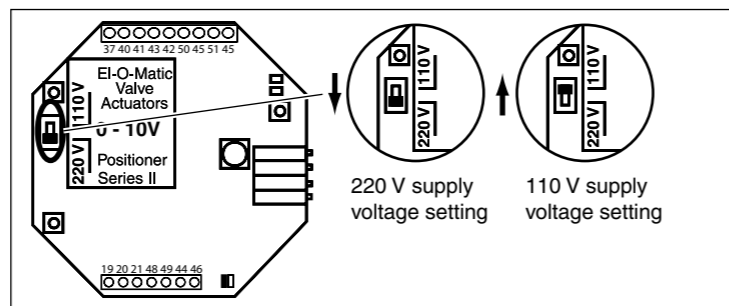

Fig. 4 Voltage selector switch setting (not on 3 Phase)

10. Make connections as shown on the wiring diagram.

Wiring diagram see drawing nr.:		
Actuator	Phase	Drw.
EL 55	1	990.40.037
EL100-1600	1	990.40.038
EL100-2500	3	990.40.039

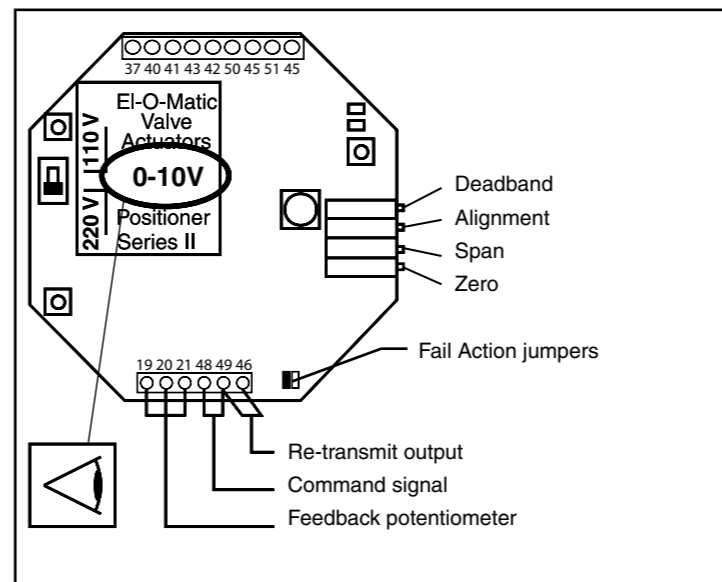

Fig. 5 Electrical connections and settings

Important notes:

1. All signal wires are to be free of electrical noise and interference. It is recommended that all signal wires be run in shielded cable.
2. If unit gives a 10V reading at closed valve position or a 0V reading at open valve position, check potentiometer wiring (direct action).
3. If unit moves towards closed position when a higher command signal (or visa versa) is given, check motor wiring (direct action).
4. If unit does not move to the fully open or closed position, check zero, span and alignment settings.

Output signal setting.

To achieve a proper functioning of the positioner, this setting has to be made, even though the signal may not be required.

1. Apply power to the unit (terminals 11 and 12). Check voltage selector switch (see fig 4).
2. Connect a milli-amp meter (preferably digital) to terminals 46 (+) and 49 (-).

Deadband.

3. Normally the 'Deadband' is set so that the actuator will not track variations of less than $\pm 0.5\%$ in the process control signal. Minimum deadband setting (fully ccw) is usually satisfactory, but if the actuator seems to 'Hunt' it may be necessary to use a higher deadband setting (turn 'Deadband' trimmer clock wise (CW) for higher setting).

Alignment of in- and output signals.

4. Connect a variable voltage source to terminals 48 (+) and 49(-), and apply a 5 volt
5. The actuator should now move to an intermediate position. Adjust the 'Alignment' trimmer so that a 5V reading is achieved on the meter connected to terminals 46 and 49.
6. Turn the actuator to the fully closed position (just before limit switch trips) and adjust the 'Zero' trimmer so that a 0V reading is achieved. 0V reading is only possible when action jumper is set to fail to close. (see below point 9).
7. Turn the actuator to the fully open position (just before limit switch trips) and adjust 'Span' trimmer so that a 10V reading is achieved.
8. Because the zero and span trimmers affect one another, it may be necessary to alternate between the max. and min. signal once or twice more and 'fine tune' the zero and span controls until the correct reading is achieved.

Fail Action Setting

1. **Default setting:** When the jumper is set at J3 (Failsafe), the positioner can only work between 1V and 10V! 'Failsafe' means that when the input signal is disconnected the actuator will stay at it's last position.
2. When the jumper is set at J4, the positioner is set to fail to 0V. This means that if the input signal is disconnected the actuator will go to the 0V position ('Close' for direct and 'Open' for revers action).
For reverse action, fail to close is not possible.

Reverse action

1. The MOD-Board can also be used for revers action. This means that a 0V signal is the 'Open' and 10V is the 'Closed' position.
2. To set the actuator for revers action, make the connections as shown on the wiring diagrams. Except the wiring of the limit switches, the motor and the potentiometer (see table 'Connections for revers action').

Connections for reverse action		
Wiring of :		to Mod Board:
Motor	2	43
	3	42
	4	41
Limit switches	7	51
	10	50
Potmeter	yellow	19
	black	20
	blue	21

Installation Instruction

990.40.103 Rev. C
January 2012

