

# Data sheet

Sheet No.: A5.103 Rev. B

Date: January 2012

## DIMENSIONS AND TECHNICAL DETAILS - ELECTRIC ACTUATOR

EL

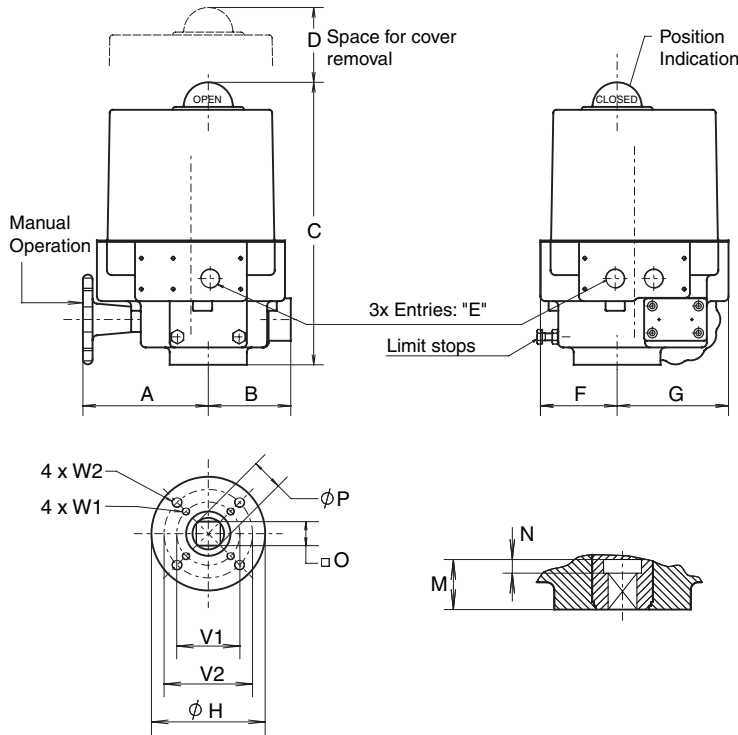

### Description

Type EL electric actuators use worm and wormwheel reduction gearing to provide tight positioning control and the self locking feature necessary for controlling larger valves, in particular butterfly valves.

The housing consists of an aluminium base casting and a steel cover, this contains the drive motor and worm gear assembly, together with the anti-condensation heater and main terminal block.

EL actuators takes the full range of control options, they have handwheel geared manual overrides, mechanical end position stops and position indication by a raised dome in the top cover.

### General Specification

- Nominal Rotation : 90° - factory set to ±3°
- : Adjustable by limit switches: 10° to 320°
- Enclosure : NEMA 4
- Temperature range : -4° to +158° F
- Electrical connections : By 12 and/or 16 point terminal block
- Finish : Two part polyurethane  
all steel parts zinc plated
- Life : 50,000 cycles minimum
- Limit switches : 4x SPDT V3 micro switches
- Torque switches : 2x SPDT V3 micro switches (Not on EL-20 & EL-55)
- Stall protection : By thermostat in motor windings
- Heater : 10 Watt
- Motor voltages and types
  - DC : 24VDC
  - AC Single phase : 24VAC 50/60Hz
  - : 110-130VAC 50/60Hz
  - : 220-280VAC 50/60Hz
  - AC Three phase : 380-460VAC 50/60Hz

### Materials

- Housing : Aluminium alloy
- Cover : Steel
- Drivesleeve : Bronze  
(Cast Iron)
- Fastenings : Stainless steel

Dim in inches	EL35 & 55	EL100	EL150	EL200	EL350	EL500	EL800
A	5.12	5.31	5.31	6.69	6.69	7.68	7.68
B	2.36	3.23	3.23	4.29	4.29	5.04	5.04
C	10.04	11.50	11.50	12.40	12.40	12.52	14.02
D	5.71	6.50	6.50	6.50	6.50	6.50	7.48
3x E	1/2"NPT	1/2"NPT	1/2"NPT	3/4"NPT	3/4"NPT	3/4"NPT	3/4"NPT
F	2.76	3.03	3.03	3.78	3.78	4.84	4.84
G	3.74	4.72	4.72	5.53	5.53	6.54	6.54
H	3.54	3.54	3.54	4.92	4.92	5.91	5.91
M	1.08	1.30	1.30	1.30	1.30	1.89	1.89
N	0.35	0.35	0.35	0.35	0.35	-	-
O max.	0.556	0.752	0.752	0.752	0.752	1.068	1.068
O min.	0.551	0.748	0.748	0.748	0.748	1.063	1.063
P	0.709	0.984	0.984	0.984	0.984	1.417	1.417
V1	1.969	1.969	1.969	2.756	2.756	4.016	4.921
V2	2.756	2.756	2.756	4.016	4.016	-	-
W1	1/4-20 x .47	1/4-20 x .47	1/4-20 x .47	5/16-18 x .59	5/16-18 x .59	3/8-16 x .71	1/2-13 x .79
W2	5/16-18 x .59	5/16-18 x .59	5/16-18 x .59	3/8-16 x .71	3/8-16 x .71	-	-

### Minimum customer switch or contactor rating 16Amp.

Performance		EL35	EL55	EL100	EL150	EL200	EL350	EL500	EL800
Torque (lb-in)	Break	310	487	885	1328	1770	3098	4425	7081
	Run	112	177	310	469	620	1089	1549	2478
Speed (Sec.)	50Hz	6	6	7.5	9	13.5	22	25.5	25.5
	110V AC	1.1	-	2.9	2.9	2.9	2.9	2.9	4.5
Current (A) (Max.)	230V AC	-	0.6	1.7	1.7	1.7	1.7	1.7	2.3
	24V DC	-	5	8	8	8	8	8	-
	110V AC	100	-	225	225	225	225	225	315
Power (W)	230V AC	-	72	200	200	200	200	200	305
	24V DC	-	45	118	118	118	118	118	-
	Switches-Indication	4x16A	4x16A	4x16A	4x16A	4x16A	4x16A	4x16A	4x16A
Torque SPDT at 110/240VAC		-	-	2x16A	2x16A	2x16A	2x16A	2x16A	2x16A
Weight (lb.)		13	13	24	24	36	37	56	57
Duty rating		30%	30%	30%	30%	30%	30%	30%	30%

**EL-O-MATIC**

www.El-O-matic.com

Copyright © Emerson Process Management. The information in this document is subject to change without notice.

Updated data sheets can be obtained from our website [www.El-O-Matic.com](http://www.El-O-Matic.com) or from your nearest Valve Automation Center **USA:** +1 813 319 0266 **Europe:** +31 74 256 10 10 **Asia-Pacific:** +65 6501 4600



**EMERSON**  
Process Management