

## Data sheet

Sheet No.: 5.104 Rev. A

Date: November 2009

## DIMENSIONS AND TECHNICAL DETAILS - ELECTRIC ACTUATOR

ELS

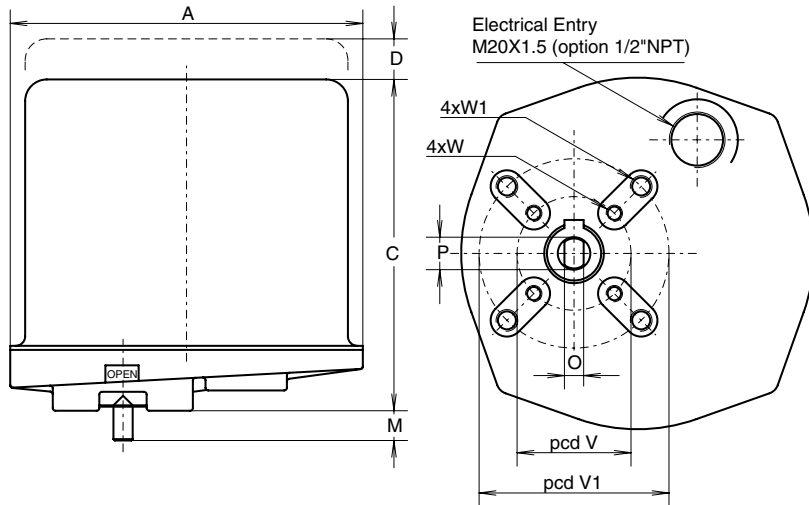

Bottom view

Dimensions (in mm.)		ELS18	ELS25	
A		130	157	
C		122.5	135	
D		85	100	
M		11.2	13	
O	7.09	+0.05 -0.00	10	+0.00 -0.09
P	11.09	+0.03 -0.00	12	+0.00 -0.09
Vstd		42	50	
(option)		50	-	
V1		-	70	
W		M6x9	M6x12	
W1		-	M8x15	
<b>Performance</b>				
Torque (Nm.)	Break	18	25	
	Run	14	20	
Speed (sec.)	50Hz	6.5	9.5	
Current (A)	120V AC	0.55	0.6	
	230V AC	0.1	0.3	
Weight (kg.)		2.2	2.8	

### Description

A compact, robust range of electrical actuators. Especially designed for small two and three way ball valves and similar drives requiring 90 or 180 degrees of rotation from a single phase or DC. electrical supply.

The water tight, aluminium alloy housing with steel cover, contains the drive motor and spur gear box assembly together with the anti-condensation heater and main terminal strip. Two limit switches provide for position limiting and remote position indication, space is allowed for two extra switches or a potentiometer for additional position feed back.

### General Specification

Rotation	: 90°
	: adjustable by limit switches: 10° to 320°
Enclosure	: IP65.
Temperature	: -20° to +70°C
Electrical connections	: By 8 point internal terminal strip
Voltages	: 24VDC or 24VAC
- Single phase	: 110-130V 50Hz or 60Hz
	: 220-240V 50Hz or 240-280V 60Hz
Minimum Switch	
Contactor Rating	: 16A
Duty rating	: 50%
Stroke limitation	: By limit switches
Visual indication	: By direction arrow on the drive spindle
Feedback switches	: 2, at 10 or 16 Amp. (at 110/240V AC) SPDT
Stall protection	: By motor thermostat
Materials	: Base plate : Aluminium alloy
	: Cover : Steel
	: Drive spindle : Stainless steel
	: Fastenings, etc. : Stainless steel
Finish	: Two part polyurethane finish
Life	: 100,000 operations minimum
Heater	: 10 Watt (Option)
Options	: Other drives and mountings
	: Extra switches, potentiometer
	: Other mounting flanges

**EL-O-MATIC™**

www.El-O-matic.com

Copyright © Emerson Process Management. The information in this document is subject to change without notice.

Updated data sheets can be obtained from our website [www.El-O-Matic.com](http://www.El-O-Matic.com) or from your nearest Valve Automation Center **USA:** +1 813 319 0266 **Europe:** +31 74 256 10 10 **Asia-Pacific:** +65 6501 4600



**EMERSON™**  
Process Management