

Data sheet

Sheet No.: A5.207 Rev.A
Date: November 2009

EL ACTUATOR WITH LOCAL CONTROL STATION - (Kit option)

LC

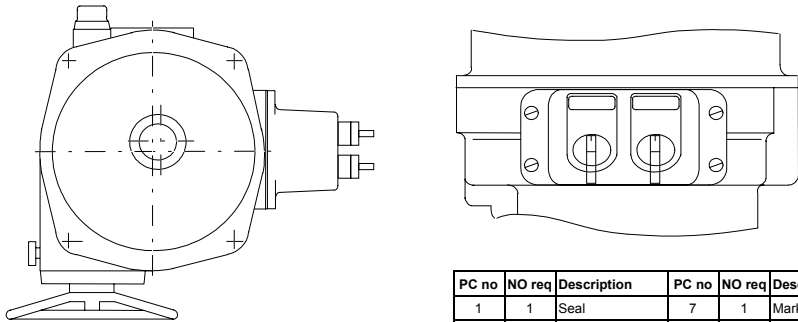

PC no	NO req	Description	PC no	NO req	Description
1	1	Seal	7	1	Marking tag
2	4	Screw	8	1	Selector knob
3	4	Lock washer	9	1	Selector knob
4	4	Contact block	10	1	Marking tag
5	1	Housing l.r.c.stat.	11	2	Adapter
6	2	Nameplate	12	1	Contact block

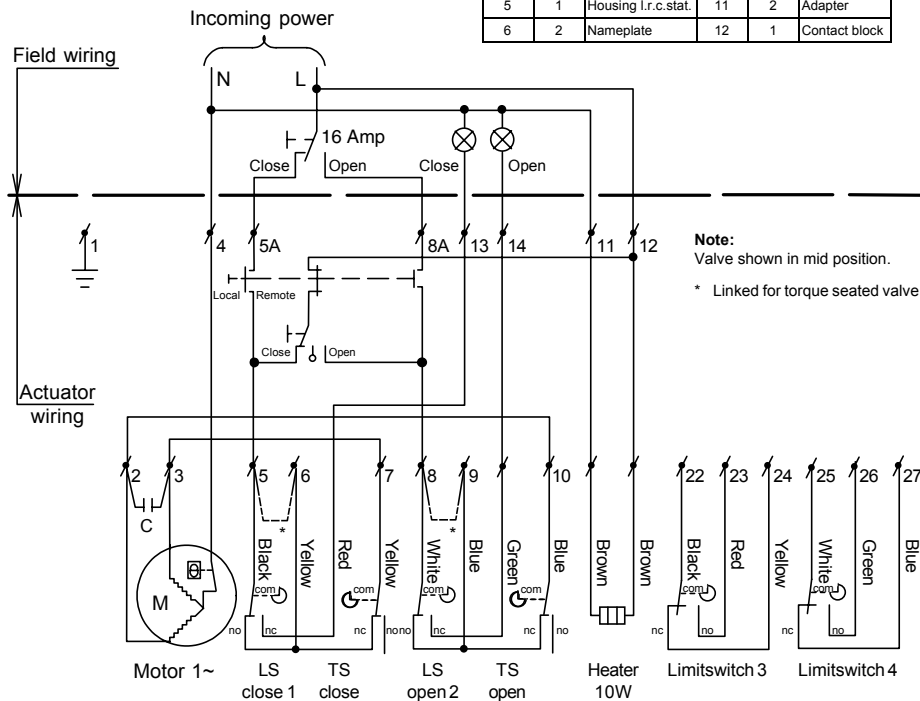

Description

This electric actuator variation has the addition of a local control box, which has two switches.

The first is a selector switch to switch between "LOCAL" and "REMOTE" operation of the actuator. When "LOCAL" is selected the second switch may be used to open, stop or close the valve, this switch is locked out when "REMOTE" is selected and the control is returned to the remote control station.

Construction

The control box is located on the side of the actuator casting and all the connection wiring is contained internally.

Specification

Switches: Make : Sprecher & Schuh
 First switch : LC1-10-10020NL
 Second switch : LC1-10-3501
 Voltage : Up to 600V
 Current : 10A max
 Temperature : -13°F to +140°F

Identification

Factory Option : Add "+ LC" to the basic actuator size
 : eg. EL100 120/60 + LC
 Kit Option : Actuator size is added to: "Kit, LC"
 : eg. Kit, LC/EL55 120/60

Variations

: Other switch inserts for key lock, etc.

Note

: When supplied as a kit option, all the components as shown are included, together with an instruction sheet
 : Wiring diagram for EL100-1600 120V/60Hz + LC

EL-O-MATIC™

www.El-O-matic.com

Copyright © Emerson Process Management. The information in this document is subject to change without notice.

Updated data sheets can be obtained from our website www.El-O-matic.com or from your nearest Valve Automation Center **USA:** +1 813 319 0266 **Europe:** +31 74 256 10 10 **Asia-Pacific:** +65 6501 4600



EMERSON™
Process Management