

ELS Electric Valve Actuator

ELS 18 & ELS 25

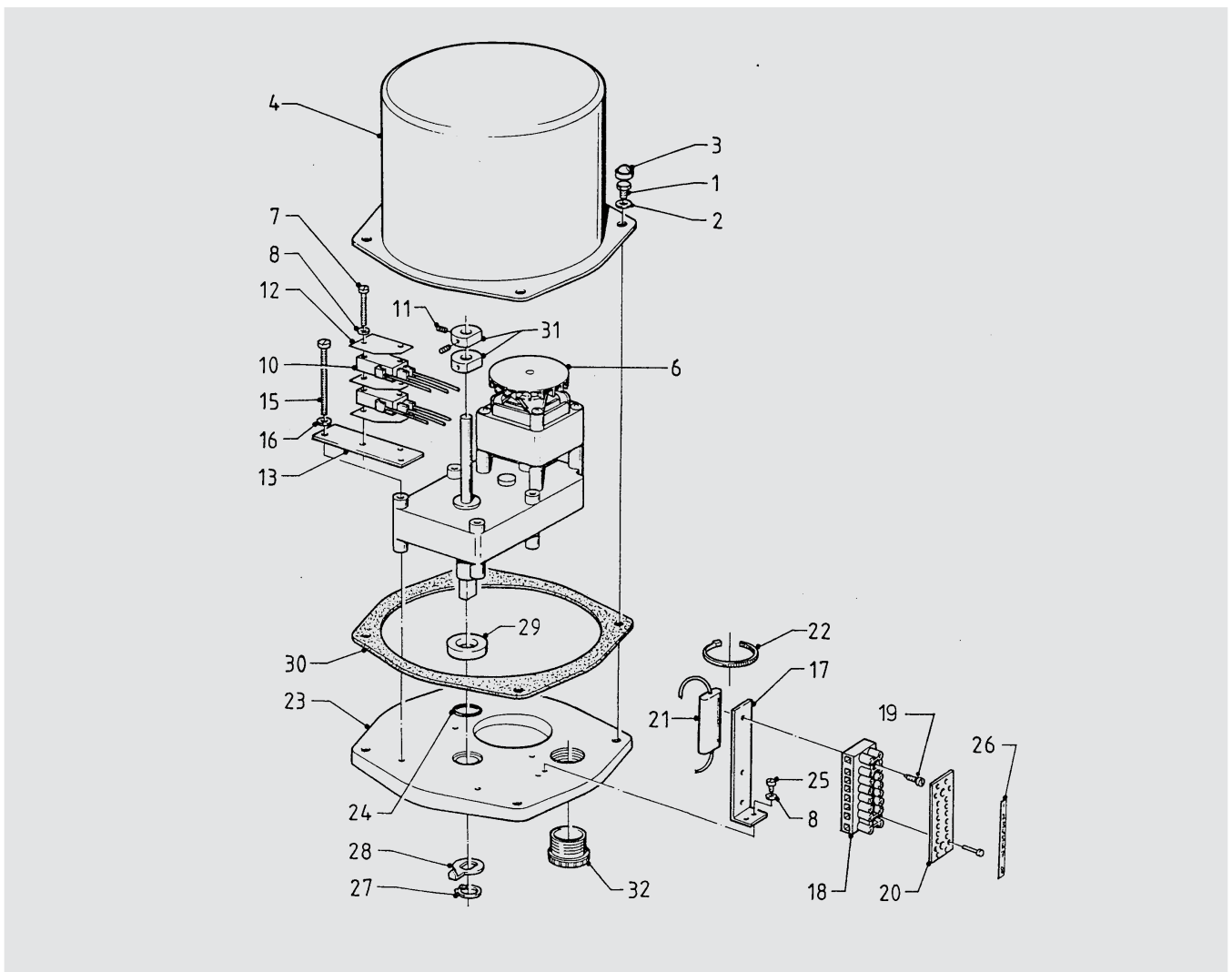

1.0 Introduction

The ELS 18 and ELS 25 are small, economical, spur-gear type valve actuators that are ideally suited to automate small ball valves. Incorporating electrically reversible, permanent split-capacitor AC single phase motors, adjustable cam activated limit switches, and tubular-screw style terminal strips for connection of electrical supply and control wiring.

They are easy and straightforward to install, and require no periodic maintenance. Panel mounted end-of-stroke indicator lamps may be powered directly from the actuator terminal strip without the need switches in the actuator (lamps not supplied with actuators).

The actuator housing is weatherproof and is finished in a two-part polyurethane paint system to withstand most common industrial environments. A threaded conduit entry (M20x1.5 or 1/2" NPT) is provided in the actuator base, permitting the cover to be removed without disturbing the wiring connections.

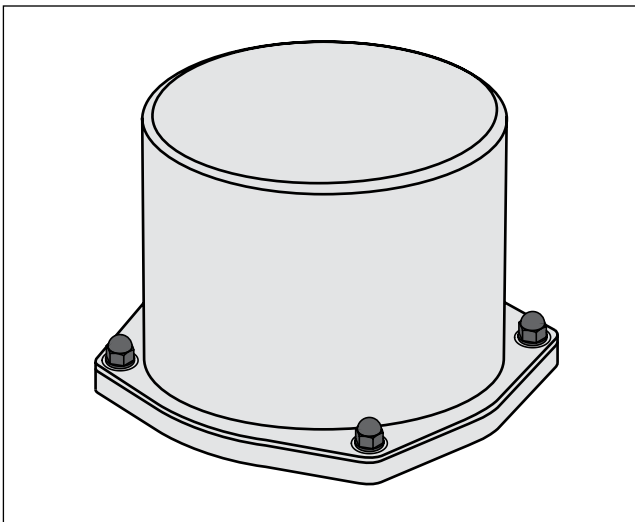

Fig. 1.0 ELS 18 and ELS 25 small, economical, spur-gear type valve actuators

1.1 Valve Selection

Ideally, valves intended for automation should be selected early in the control system design process. Valves intended for automation must be selected according to several criteria:

1.1.1 Torque:

Since a Valve actuator's primary specification is torque (the force it can deliver to turn the valve stem), to successfully automate a valve, the valve's torque requirement must be known. This sounds simple until an attempt is made to acquire this information. Selection of the valve must begin with a source that not only can provide the desired mounting method and process compatibility, but also reliable torque specifications for the specific process conditions under which the valve will be operated. The actuator should be selected to have a margin of reserve torque as well, to ensure reliable operation within a range of process and plant conditions.

1.1.2 Actuator Mounting Facility

Not all valves designs lend themselves to actuator mounting requirements. Some type of bolting flange around the stem (typical of butterfly valves) provides a nice attachment point for an actuator. Ball valves are not typically designed with such a flange, but if the valve is selected to be of the pipe-flange mounting style (rather than threaded end, union, or sweat-type) then the actuator bracket can be bolted through the pipe flanges.

Plug valves often look like good candidates for automation, but the flange around the stem can be misleading. It is typically provided to maintain tension on the plug, and not for mounting of an actuator. Modifying this type of valve for actuator mounting can cause problems in the areas of plug sealing (shut-off) and torque. When in doubt, consult the valve manufacturer on the compatibility of the valve with the requirements of automation before buying the valve.

2.0 Mounting to the valve

2.1 Shaft Coupling

The actuator is provided with a “double-D” male output shaft which will require an adapter to couple the actuator to the valve stem.

Suggested is to include wrench flats to the coupler to allow manual operation.

Valve coupling “blank adapters” are available, from your EL-O-MATIC distributor, which have the correct actuator-end treatment, with the valve end unfinished.

2.2 Valve Bracket

The drilling patterns in the bottom of the actuator are according ISO 5211. In most cases, a bracket must be fabricated to mount the actuator to the valve.

2.3 EL-O-MATIC Actuator Sizing And Engineering software

The EL-O-MATIC Actuator Sizing And Engineering software (available from www.el-o-matic.com) provides recommendations for:

- * Coupler material and diameter versus length, should you wish to fabricate the coupling from “scratch”.
- * Hot-Line Applications where heat is transferred from a hot process pipe into the actuator. This will deactivate the actuator when its internal temperature reaches approximately 135°C (275°F). These recommendations minimize the heat transfer from a process pipe, by simply extend the bracket and coupling, to place the actuator further from the valve and pipe.
- * Another method of reducing heat gain by the actuator, if space for an extended bracket is lacking, is to interpose a sheet of light-gauge aluminium or steel between the bracket and actuator. This shield will be more effective if installed between the valve and bracket, rather than between the actuator and bracket. The side of the shield facing the heat should ideally be reflective, and NOT painted a dark color.

2.4 Manual Operation

The ELS, being a spur gear actuator, can be manually operated, in the event of a power failure, for example, by turning the actuator output shaft with an open-end wrench (hence; the reference to wrench flats, above).

It is therefore recommended that the installation be planned to allow access to the actuator shaft coupling for this purpose.

The installation should also provide service access to the actuator electrical compartment for ease of limit switch setting and actuator wiring. The actuator can be mounted in any position (right-side up, up-side down, or sideways).

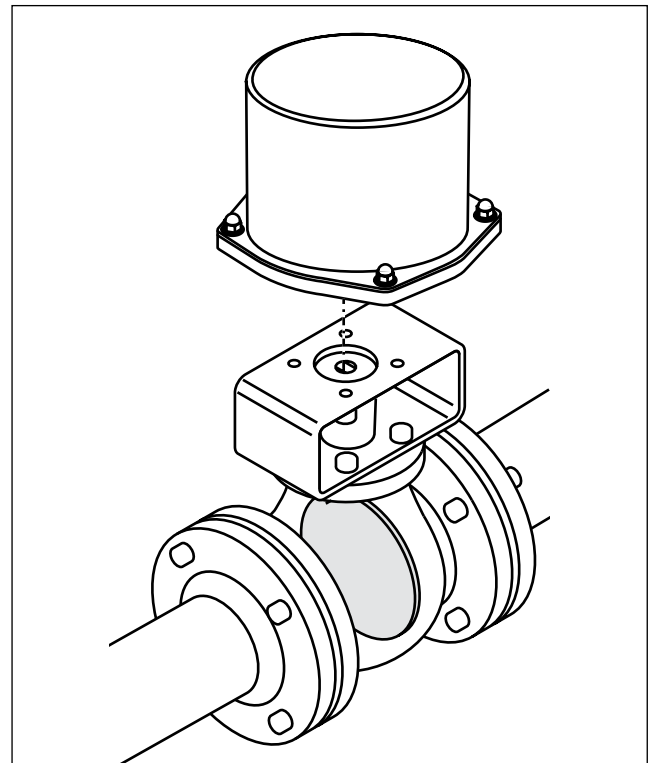

Fig. 2.0 Mounting to the valve

3.0 Actuator Adjustments

3.1 Setting Limit Switches

EL's limit switches are preset at the factory for a nominal 90° of rotation, however, it is recommended that the limit switch settings be checked, and adjusted if necessary, after the actuator is mounted to its valve.



WARNING:

- * If the electric actuator is used in a manner not specified by the manufacturer, the protection provided by the equipment may be impaired.
- * For electrical safety the marked protective conductor terminal inside or outside the actuator housing shall be connected to earth.
- * If required, mount earth wire (1) between top (2) and bottom (3) ring of earth wire connection.

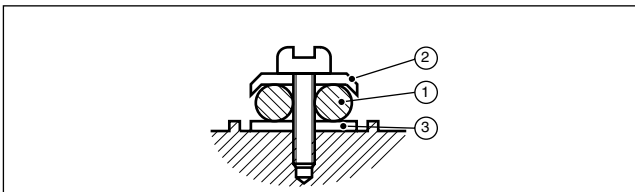

Fig 3.1 earth wire connection

- * To fulfill the electrical safety regulations according IEC 61010-1, a switch or circuit-breaker shall be included in the building installation. It is advised to indicate the location of the circuit breaker by means of a label on or nearby the installed ELS actuator. The disconnection switch or circuit-breaker shall disconnect all current-carrying conductors.



**CAUTION!
RISK OF ELECTRIC SHOCK**

- * Hazardous voltages are present in the actuator, and are exposed with actuator cover removed.
- * Installation, adjustment, putting into service, use, assembly, disassembly and maintenance of the electric actuator is strictly reserved to qualified personnel.

Tools needed for this procedure:

- 2 mm hex (alien) wrench (limit-switch cams),
- 7 mm open-end wrench or "nut-driver" (ELS18 cover screws) or,
- 10 mm open-end wrench or "nut-driver" (ELS25 cover screws),
- 1/8" common screwdriver with insulated shank (terminal-strip screws)

3.2 Procedure

- 1 Mount the actuator to the valve.
- 2 Remove actuator cover.
- 3 Guide the cable through the electrical entry.
 - Use and mount a cable gland as required by national or local legislation.
 - When IP65/NEMA4X ingress protection is required, the electrical entries must be fitted with glands rated IP65/NEMA4X or higher.
- 4 Make the electrical connections following the wiring diagram as shipped in the actuator electrical compartment (see also chapter 9 or 10).
5. Electrically operate the actuator/valve in the clockwise (close) direction of rotation.
6. Check that the actuator stops rotating at the correct position relative to the valve seat.
6. Perform the same test for the counter clockwise (open) direction of rotation.

If either the open or close stroke (or both) needs to be adjusted, follow the steps outlined below:

3.3 Clockwise (close) limit switch adjustment

1. Loosen set screws (11a) in cam (31a) for limit switch #1 (10a)
2. Use the 2mm Allen wrench, as a “handle”, to rotate the cam until curved portion is in contact with the switch lever.
- 3 Rotate the cam clockwise until an audible “click” is heard. The click Indicates that the switch has „tripped”, and is in the off state. Stop rotating the cam as soon as the click is heard.
- 4 Tighten the set screws.

3.4 Counter clockwise (open) limit switch adjustment.

For counter clockwise limit switch setting, perform the same steps as for clockwise limit, except rotate cam #2 (31b) counter clockwise until the click is heard. Tighten cam set screws.

Re-check by operating the actuator again electrically to be certain the settings are OK.

If the wiring connections were made in a temporary manner for testing purposes, remake the connections by routing the wiring through a proper conduit gland in the actuator base.



Important

- * Seal the gland threads where they enter the actuator with pipe dope or Teflon tape.
- * Tighten the gland nut to achieve a good seal to the conduit. Re-check electrical operation before replacing cover.
- * When mounting the cover, take care that the cover seal is in place to comply to dust and water tightness according to IP65 / NEMA4X.
- * Tighten the cover screws sufficiently to form a good seal to the cover gasket.
- * To prevent cover distortion and consequent water leaks, DO NOT OVERTIGHTEN COVER SCREWS.

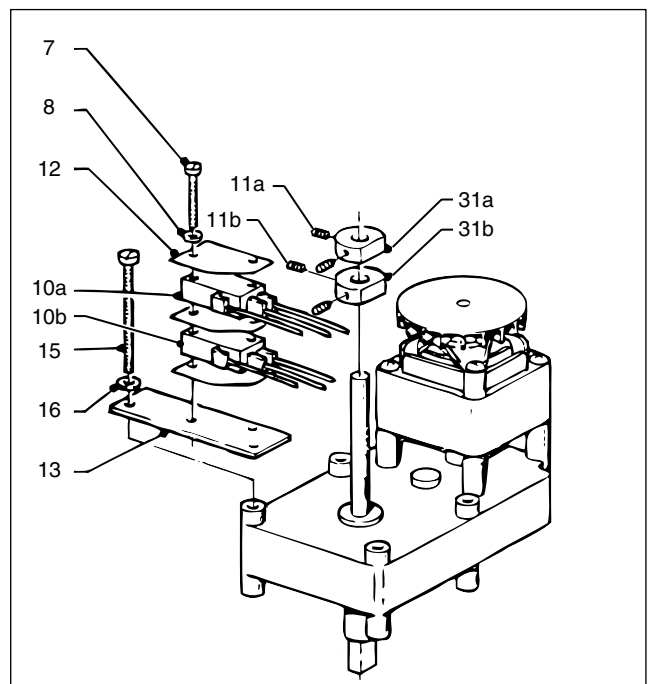

Fig. 3.2 Limit switch setting

4.0 Control Circuitry

Always refer to actuator wiring diagrams when designing actuator control systems or installing actuators

! WARNING !

DO NOT wire actuators in parallel!

Use a separate control switch or relay for each actuator. Paralleled actuators may run in opposite directions, and may stall and overheat.

"Neutrals" may be "daisy-chained" from one actuator to another in installations where many actuators are located in close Proximity.

4.1 Manual Remote Control

The simplest form of control circuit is the single-pole double-throw panel switch. A momentary switch with a centre-off position is recommended where the valve must be "jogged" into position. It is only necessary to run two wires from the switch to the actuator when the neutral wire is daisy-chained from one actuator to another.

4.2 Signalling Options

The standard limit switches in ELS actuators will provide end-of-stroke lamp indication using panel lamps. Two wires need to be brought from the actuator to the lamp panel if the common neutral is available in the panel. Otherwise, the neutral will have to be brought from the actuator to the panel as well.

"XS" auxiliary switches

If isolated dry contacts are needed for signalling a PLC or computer, order two auxiliary switches (model ,XS) which are cam-activated and can be set to trip anywhere within the normal stroke of the actuator (follow limit switch setting procedure above for adjustment method).

"POT" potentiometer

A gear-driven potentiometer (model POT, available in 1 kOhm and 10 kOhm resistance values, and in 90° or 180° rotation) is available for installation in ELS actuators to provide panel-meter position read-out for re-setability of valve position (meter and power supply not included with actuator).

5.0 Troubleshooting

Although we would not expect you to experience any problems with your EL-O-MATIC valve actuator we have listed some checkpoints should your actuator not function as desired.

5.1 Rotation

If limit switch fails to stop valve travel, check the following:

- Direction of rotation of output shaft
- Control wiring
- Limit switch setting

5.2 Motor Not Running

If unable to operate your EL-O-MATIC by motor:

- Check both power and control circuits for supply and continuity.
- Compare supply voltage with motor nameplate, if OK, then check motor amperage load.

5.3 Overload

Motor overheating and/ or high motor amperage load can indicate the following:

- Excessive valve load.
- Valve packing gland too tight.
- Improperly lubricated valve.
- Incorrect Motor capacitor.
- Ambient temperature too high.
- Valve cycling too often.
- Incorrect voltage.
- Incorrect wiring.

5.4 No Valve Movement - Motor Runs

- Drive sheared or not connected

5.5 No Valve Movement - Motor won't run

- Valve plug/disk jammed or obstructed.
- Valve requires torque higher than actuator rated torque.
- Valve packing gland too tight.

6.0 Parts and Materials ELS-18

No.	Qty.	Description	Material	No.	Qty.	Description	Material
1	4	Screw	Steel	17	1	Terminal Bracket	Steel
2	4	Lock Washer	Steel	18	1	Terminal Block	
3	4	Domed Cap Nut	Nylon	19	2	Screw	Steel
4	1	Cover	Steel	20	1	Marking Tag	
6	1	Motor		21	1	Capacitor	
7	2	Screw	Steel	22	1	Cable Tie	
8	2	Tooth Washer	Steel	23	1	Motor Support Plate	Aluminium
9	2	Spacer	Nylon	24	1	O-ring	Buna-N (Nitrile)
10	2	Micro Switch		25	2	Screw	Steel
11	4	Screw	Steel	26	1	Sticker Terminal No's	
12	3	Insulation Plate		27	1	Retaining Ring	Steel
13	1	Limit Switch Bracket	Steel	28	1	Position Indicator Arrow	
15	2	Screw	Steel	30	1	Gasket Cover	
16	3	Lock Washer	Steel	31	2	Limit Switch Cam	Aluminium
				32	1	Blind stop	

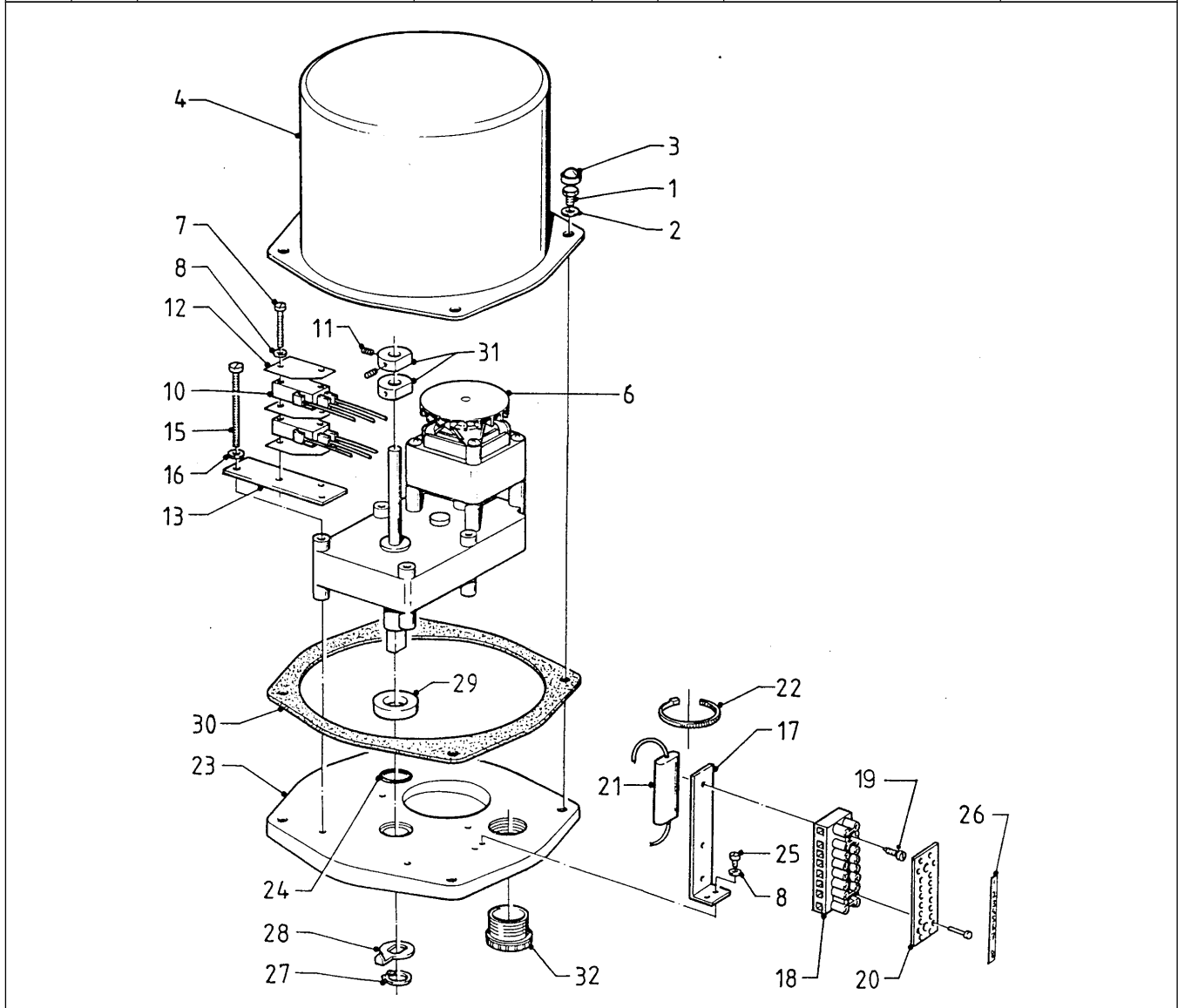

7.0 Parts and Materials ELS-25

No.	Qty.	Description	Material	No.	Qty.	Description	Material
1	4	Screw	Steel	19	2	Screw	Steel
2	4	Lock Washer	Steel	20	1	Marking Tag	
3	4	Domed Cap Nut	Nylon	21	1	Capacitor	
4	1	Cover	Steel	22	1	Cable Tie	
6	1	Motor		23	1	Motor Support Plate	Aluminium
7	2	Screw	Steel	24	1	O-ring	Buna-N (Nitrile)
8	4	Lock Washer	Steel	25	2	Screw	Steel
10	2	Micro Switch		26	1	Sticker Terminal No's	
11	4	Screw	Steel	27	1	Retaining Ring	Steel
12	3	Insulation Plate		28	1	Position Indicator Arrow	
13	1	Limit Switch Bracket	Steel	29	1	Adapter O-ring	Buna-N (Nitrile)
15	3	Screw	Steel	30	1	Gasket Cover	
16	3	Lock Washer	Steel	31	2	Limit Switch Cam	Aluminium
17	1	Terminal Bracket	Steel	32	1	Blind stop	
18	1	Terminal Block					

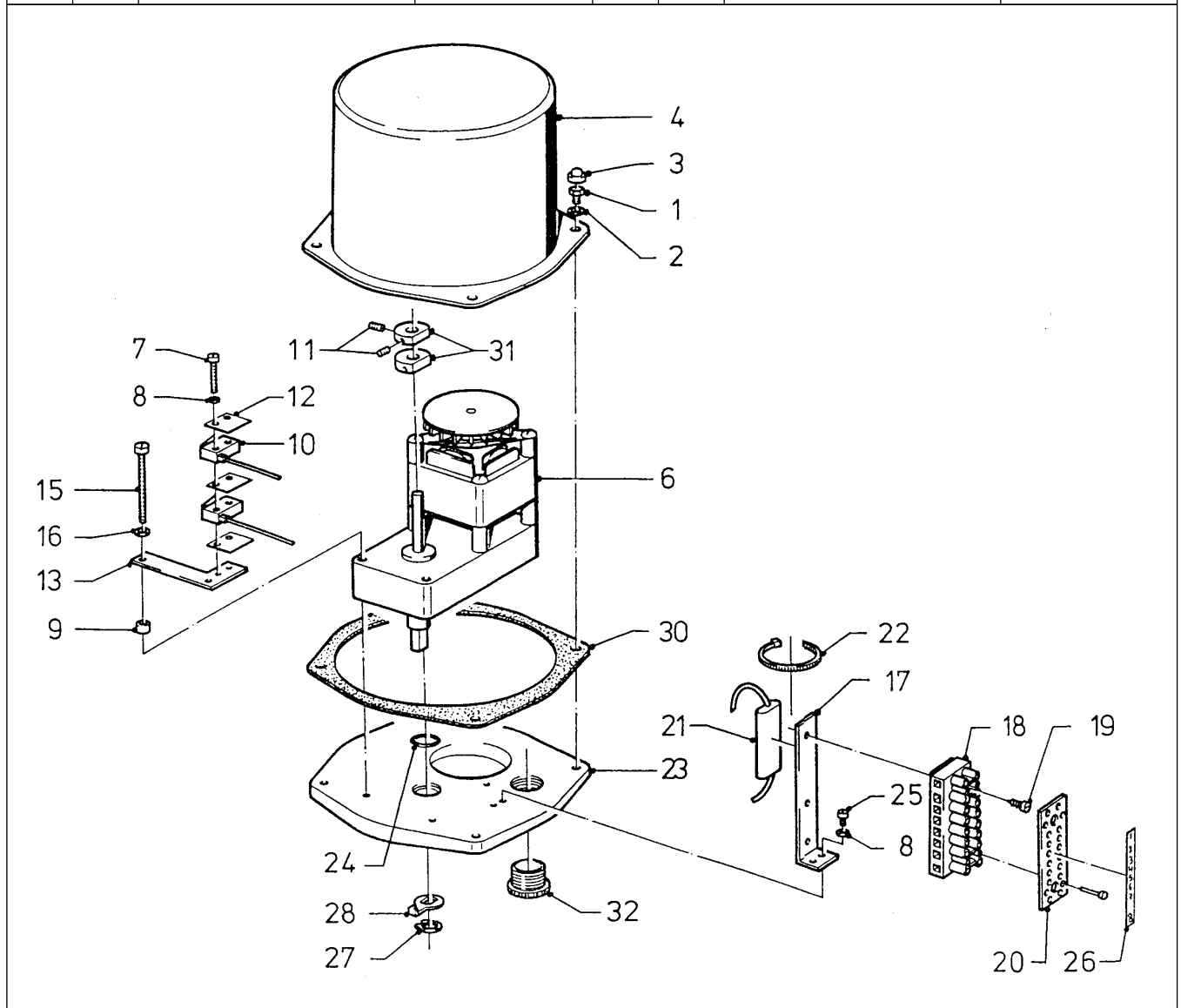

9.0 Wiring diagram 990.40.021, ELS 1-phase

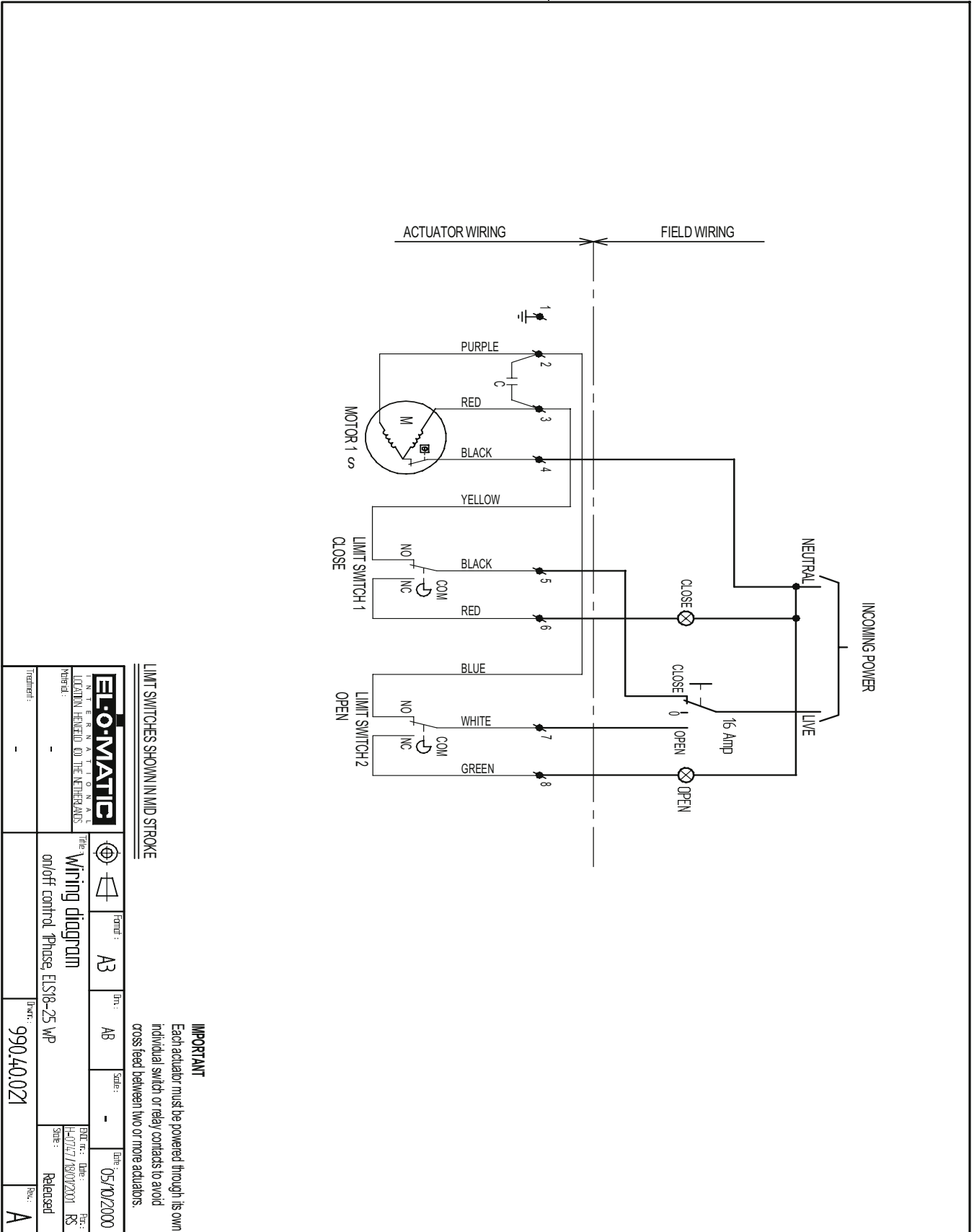

Contact Us:

Emerson Process Management, Valve Automation facilities at your nearest location
or visit our web site for up to date product data: www.El-O-matic.com

North & South America

18703 GH Circle
PO Box 508
Waller, Texas 77484
USA
T +1 281 727 5300
F +1 281 727 5353

2500 Park Avenue West
Mansfield, Ohio 44906
USA
T +1 419 529 4311
F +1 419 529 3688

9009 King Palm Drive
Tampa , Florida 33619
USA
T +1 813 630 2255
F +1 813 630 9449

4112-91A Street
Edmonton, Alberta T6E5V2
Canada
T +1 780 450 3600
F +1 780 450 1400

Av. Hollingsworth,325
Iporanga
Sorocaba, SP 18087-105
Brazil
T +55 15 3238 3788
F +55 15 3228 3300

Europe

Asveldweg 11
7556 BT Hengelo(O)
The Netherlands
T +31 74 256 1010
F +31 74 291 0938

Siemensring 112
D-47877 Willich
Germany
T +49 2154 499 660
F +49 2154 499 6613

30/36 Allee du Plateau
93250 Villemomble
France
T +331 48 122610
F +331 48 122619

6 Bracken Hill
South West Industrial Estate
Peterlee, Co Durham
SR82LS, United Kingdom
T +44 191 518 0020
F +44 191 518 0032

3 Furze Court
114 Wickham Road
Fareham, Hampshire
PO167SH ,United Kingdom
T +44 132 984 8900
F +44 132 984 8901

Middle East & Africa

2 Monteer Road, Isando
Kempton Park, 1600
South Africa
T +27 11 974 3336
F +27 11 974 7005

PO Box 17033
Jebel Ali Free Zone
Dubai,
United Arab Emirates
T +971 4883 5235
F +971 4883 5312

Asia Pacific

19, Kian Teck Crescent,
Singapore 628885
T +65 6262 4515
F +65 6268 0028

9/F Gateway Building
No.10 Ya Bao Road
Chaoyang District
Beijing, P.R. China
T +86 10 5821 1188
F +86 10 5821 1100

No 15 Xing Wang Road
Wuqing Development Area
Tianjin 301700
P.R. China
T +86 22 8212 3300
F +86 22 8212 3308

Lot 13111, Mukim Labu,
Kawasan Perindustrian Nilai
71807 Nilai, Negeri Sembilan
Malaysia
T +60 6 799 2323
F +60 6 799 9942

471 Mountain Highway
Bayswater, Victoria 3153
Australia
T +61 3 9721 0200
F +61 3 9720 0588

301, Solitaire Corporate Park
151, M.V. Road, Andheri(E)
Mumbai-400093,
Maharashtra, India
T +91 22 6694 2711
F +91 22 2825 3394

NOF Shinagawa Konan Building
1-2-5, Higashi-shinagawa
Shinagawa-Ku, Tokyo
140-0002 Japan
T +81 3 5769 6873
F +81 3 5769 6902

All Rights Reserved.

We reserve the right to modify or improve the designs or specifications of the products mentioned in this manual at any time without notice. Emerson Process Management does not assume responsibility for the selection, use or maintenance of any product. Responsibility for proper selection, use and maintenance of any Emerson Process Management product remains solely with the purchaser.

©2009 Emerson Electric Co.

EL-O-MATIC

www.El-O-Matic.com

EMERSON[™]
Process Management