

# TEC2000 Electronic Valve Actuators

## Engineering and Controls Manual



## CONTENTS

<b>Introduction</b> .....	<b>2</b>
<b>Control Features</b> .....	<b>3</b>
Local Control .....	3
Setup Options .....	4
Remote Control .....	4
Two-Wire .....	5
Three-Wire .....	5
Four-Wire .....	5
Two-Speed Timer Options .....	5
Local Emergency STOP .....	6
Emergency Shutdown .....	6
Inhibits/Interlocks .....	6
Analog Position Controllers .....	7-8
Remote Display Module (RDM) .....	8-9
<b>Indication &amp; Monitoring</b> .....	<b>10</b>
Local Indication .....	10-11
Remote Indication .....	12
Monitor Relay .....	13
Analog Feedback – Position & Torque .....	13
Diagnostics & Historical Data .....	14
<b>Protection Features</b> .....	<b>15-16</b>
<b>Electrical Specification</b> .....	<b>16-19</b>
<b>Enclosure Certifications</b> .....	<b>20-21</b>
<b>Sectional View &amp; Features</b> .....	<b>22-23</b>
<b>Controlinc® Network Controls</b> .....	<b>24</b>
Modbus RTU .....	24-25
Foundation Fieldbus .....	26
Profibus .....	26
<b>Mechanical Integrity</b> .....	<b>27-28</b>
<b>Performance Data</b> .....	<b>29</b>
<b>Outline Dimensions</b> .....	<b>30-33</b>
<b>Circuit Coding &amp; Diagrams</b> .....	<b>34-35</b>
<b>Remote Control Circuits</b> .....	<b>36</b>
Two-, Three-, & Four-Wire Circuits .....	36
ESD & Inhibit/Interlock Circuits .....	37
Indication & Control Circuits .....	38-40
Controlinc® Computer Digital Networks .....	41
<b>TEC2000 Options &amp; Accessories</b> .....	<b>42</b>

## INTRODUCTION

EIM has blended digital valve control technology with mechanical components proven for decades. TEC2000's power transmission gear train has a half-century track record of dependability with its bronze worm gear, heat-treated steel rolled worm, and steel motor gears.

Even though it employs microprocessor-based control, TEC2000 still utilizes mechanical displacement torque sensing. Rather than relying on software algorithms related to such things as motor speed or pressure-sensitive rubber pads, this direct-sensing approach uses a mechanical transducer technology that has proved reliable for over 50 years.

## RELIABILITY INSIDE AND OUT

TEC2000 has been built on the solid foundation of Series 2000 (with its heritage of ruggedness, reliability and success in diverse applications worldwide) and will provide long-term service with minimal maintenance, thus ensuring low "cost-of-ownership."

It also ensures wide interchangeability of parts—a hallmark of EIM designs; in fact, 60% of parts are interchangeable across EIM's quarter-turn & multi-turn range. This interchangeability allows greater flexibility in the field, easier maintenance, and reduced spare-part stocking for hundreds of components (including motors, motor gearing, clutch assemblies, torque spring assemblies, and electrical control modules).

Logical design of TEC2000 quarter-turn and multi-turn actuators, plus addition of a few optional modules, simplifies initial engineering and procurement.

Other advantages of the TEC2000:

- Quarter-turn & multi-turn designs follow the same basic construction
- Wiring diagrams are common for all valve types
- Wide range of torques and speeds to suit most applications
- Wide range of positioning/process control options
- Motors, gears, and torque springs are easily replaced in the field if speed changes are required
- Low maintenance after many years of trouble-free service

# CONTROL FEATURES

## LOCAL CONTROL

TEC2000's **Local Display Module (LDM)**, with its unique IconoText screen, consists of the following features:

- **Graphics Display:** Displays mode of operation, valve status, position, torque, and alarm symbols.
- **Message Center:** Displays actuator setup selections, data entry feedback, and alarm messages.
- **Control Knob:** Performs normal Open/Stop/Close functions in Local Control mode, and YES/NO functions in Monitor/Setup mode.
- **Selector Knob:** Performs normal selector-switch Local/Stop/Remote function and NEXT/BACK display function in Monitor/Setup mode. (The Selector Knob may be padlocked in any of its three positions.)
- **Three LEDs:** Red/Open, Green/Close, Yellow/Stop (default).
- **IrDA Transmitter & Receiver:** Duplicates same functions as Control and Selector Knobs using EIM's optional hand-held "Clicker" remote controller, PDA, or PC.

**Figure 1: Local Display Module (LDM)**

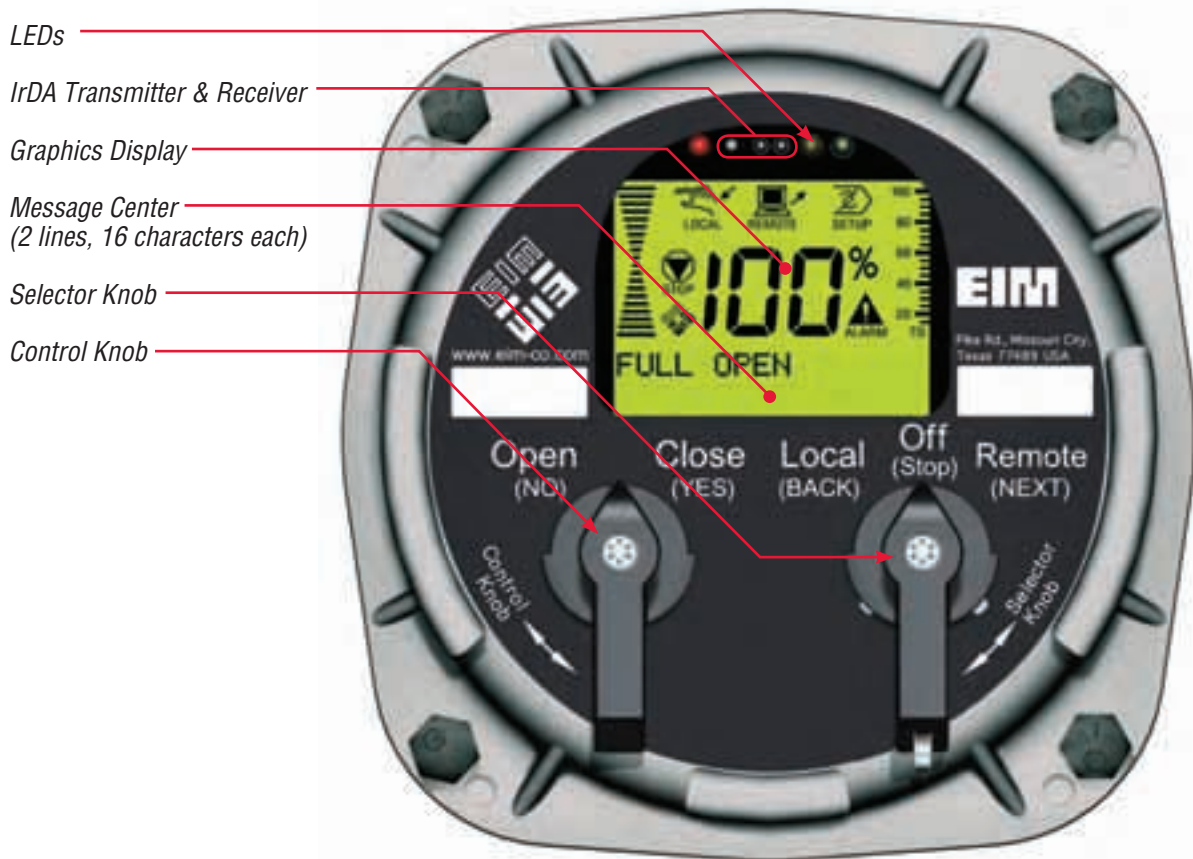

## SETUP OPTIONS

TEC2000 provides freedom to choose from any of three Tri-Set configuration setup methods:

- **Control knobs** on either the Local Display Module (LDM) or on the optional Remote Display Module (RDM), which can be mounted up to 1200 meters (4000 ft) away from the actuator.
- **PC or PDA** via RS-485 link to the actuator, or via the IrDA port, utilizing EIM's TecLinc Windows®-based software.\*
- EIM's optional **keychain "Clicker" device**. The "Clicker," an IrDA controller, has four buttons that correspond to the Yes, No, Back and Next functions of the local control knobs. The entire actuator configuration process can be completed using this compact tool. (Clicker not available in Japan or England).

**Figure 2: Tri-Set configuration**



## REMOTE CONTROL

Remote control capability permits the actuator to be controlled via a variety of discrete inputs:

- Two-wire control with either:
  - contact *closed* or digital signal *high* to OPEN valve
  - contact *open* or digital signal *low* to OPEN valve
- Three-wire control to OPEN and CLOSE valve, but with no intermediate STOP if Momentary Contact mode is selected (seal-ins activated)
- Four-wire control (default setting) to OPEN and CLOSE valve, and STOP in mid-travel
- Two-speed timer & anti-water hammer
- ESD and inhibit/interlock signals
- Futronic position controllers
- An optional RDM (Remote Display Module) is available. **See page 8 for details.**

Control can be achieved by either a Maintained Contact or Momentary Contact signal. Refer to pages 36-41 for remote wiring connections. The signal may be powered externally with a control voltage in the range 18-150VDC or 20-250VAC, or internally from 24VDC power supply derived from on-board control transformer.

Current draw for each control input:	12mA @ 24VDC, or 12mA @ 250VAC
Minimum ON voltage:	12V
Maximum OFF voltage:	6V
Minimum signal duration:	50mS

*All remote control inputs are opto-isolated – built-in surge immunity is 25kV as standard.*

**\*NOTE:** For TecLink Windows-based software, contact factory, your local distributor, or go to [www.eim-co.com](http://www.eim-co.com).

## Two-Wire Control with MAINTAINED CONTACT to Open or Close

Two-wire control mode uses only one contact to control the actuator, with that contact often being controlled by a relay. Actuator can be configured to OPEN valve either when contact is closed (digital signal *high*) or when the contact is open (digital signal *low*). Momentary Contact mode (seal-ins activated) is not possible for two-wire control: the actuator will reverse direction as soon as remote input changes state.

## Three-Wire Control with MAINTAINED CONTACT (Push-to-Run) or MOMENTARY CONTACT

Three-wire control mode uses two contacts to OPEN or CLOSE the valve. Actuator can be configured, during setup, for either Maintained Contact (push-to-run) or Momentary Contact (seal-ins activated) control mode. When Momentary Contact mode is selected, valve cannot be stopped in mid-travel except when an inhibit/interlock, ESD, or emergency STOP signal is present at terminals.

## Four-Wire Control with MOMENTARY CONTACT and MID-TRAVEL REVERSAL

Four-wire control mode uses three contacts to OPEN, CLOSE or STOP valve in mid-travel—Momentary Contact mode (seal-ins activated) being selected automatically. Default configuration for STOP input is “active on open contact,” although this can be reversed to “active on close contact” during setup.

## Two-Speed Timer (Optional)

The two-speed timer option uses microprocessor technology to control the operating time of the valve in either opening or closing direction, or in both directions. Actual speed of the actuator is not controlled, but instead, the motor is pulsed so that the rate of opening or closing is reduced. Motor pulse ON time and OFF (dwell) time, and valve position at which pulsing starts and stops, are selectable and individually adjustable for either direction of travel.

Pulse ON time:	Selectable 1–64 seconds, in 0.25 second increments
Pulse OFF time:	Selectable 1–64 seconds, in 0.25 second increments
Start and Stop positions:	Selectable 1–99% OPEN, in 1% increments

## Anti-Water Hammer (Optional)

The anti-water hammer feature provides additional protection against the valve being operated too quickly in the closing direction, as it approaches fully closed position, in order to slow rate of flow in the pipeline. Pulse time start position can be adjusted to any position between CLOSE and 30% OPEN position but pulsing will only stop when fully closed position is reached. If this feature is enabled in Setup, it will override any settings configured for the two-speed timer once start position has been reached while moving in the CLOSE direction.

Pulse ON time:	Selectable 1–64 seconds, in 0.25 second increments
Pulse OFF time:	Selectable 1–64 seconds, in 0.25 second increments
Start position:	Selectable 1–30% OPEN, in 1% increments

## Local Emergency Stop

A hard-wired emergency stop function bypasses all electronics and ensures that the actuator “stays put” regardless of any other signal present at actuator terminations. Two dedicated terminals are provided and emergency stop is initiated when an open-circuit exists between them—a link is provided as standard, ex-factory, and the user should replace this with a N.C. contact if this feature is required.

## Emergency Shutdown (ESD)

A remote ESD signal will override any local or remote-control signal (except hard-wired emergency stop feature) and command the actuator to operate the valve to a pre-selected position to either close or open the valve or to make it “stay put” in its present position.

ESD action can be configured to override the following conditions:

Motor thermal overload*	[Default setting – OFF]
Selector in Local position	[Default setting – ON]
Selector in Stop position	[Default setting – OFF]
Active inhibits	[Default setting – ON]
Torque switch trip	[Default setting – OFF]

\* **NOTE:** *Overriding the motor thermal protection may invalidate hazardous area certification.*

## Inhibits/Interlocks

Actuator can be prevented from operating in either OPEN or CLOSE direction, or both, until an external contact has been made. This is useful when interlocking with other process equipment (e.g. pumps, other valves, sensors, PLC, DCS, etc.), and it will inhibit operation in both remote and local operating modes. Default setting is ON for both directions.

Inhibit signal can be overridden by a remote ESD signal if it has been pre-selected during Setup.

Inhibit/interlock inputs are isolated from control inputs by having a separate common terminal, thereby segregating the safety system from the operational control system and also allowing different voltage levels to be used.



## Analog Position Controllers (Optional)

### A) Futronic II Position Controller

The Futronic II position controller, with electro-mechanical reversing contactor, is capable of handling position and process control via a 4-20mA input signal, and includes a 4-20mA feedback signal of position derived from a non-contacting position sensor. Units are available for either three-phase or single-phase power supplies. Suitable for operating at a rate of up to 1200 starts/hour (three-phase motors) or up to 100 starts/hour (single-phase motors).

- Accuracy:  $\pm 1\%$
- Control bandwidth: 0.1% to 5%, adjustable in 0.1% increments (default: 2%)
- Speed bandwidth: 0.5% to 9%, adjustable in 0.1% increments (default: 5%)
- Delay time: 0 to 60 seconds, adjustable in 0.25 second increments (default: 1.0 second)
- Input impedance: 250 ohm
- Input polarity: (Selectable) 4mA = Close *or* 20mA = Close (default: 4mA = Close)
- Output polarity: (Selectable) 4mA = Close *or* 20mA = Close (default: 4mA = Close)
- Loss of signal: Selectable to Fail open, Fail close, Fail to preset position, *or* Stay Put in last position (default)

### B) Futronic IV Solid-State Process Controller

The Futronic IV process controller includes a solid state reversing starter, and is capable of handling process control via a 4-20mA input signal, and includes a 4-20mA feedback of position derived from a non-contacting position sensor. Units are available for either three-phase or single-phase power supplies. Suitable for operating at a rate of up to 1200 starts/hour (three-phase motors) or up to 100 starts/hour (single-phase motors).

- Accuracy:  $\pm 0.5\%$
- Control Bandwidth: 0.1% to 5%, adjustable in 0.1% increments (default: 2%)
- Speed bandwidth: 0.5% to 9%, adjustable in 0.1% increments (default: 5%)
- Delay time: 0 to 60 seconds, adjustable in .25 second increments (default: 1.0 second)
- Input impedance: 250 ohm
- Input polarity: (Selectable) 4mA = Close *or* 20mA = Close (default: 4mA = Close)
- Output polarity: (Selectable) 4mA = Close *or* 20mA = Close (default: 4mA = Close)
- Loss of signal: Selectable to Fail open, Fail close, Fail to preset position, *or* Stay Put in last position (default)

### C) Futronic VIII Precision Process Controller

The Futronic VIII offers the highest-accuracy process control of any electric valve actuator. A variable-frequency controller (VFC) replaces the reversing contactor, and inherently provides completely solid-state motor control and auto-phase correction. Futronic VIII uses only two speeds, normal and slow, with speeds being programmable at the VFC. Normal speed is typically set as standard full speed of the motor at either 50 or 60Hz, but it may be set at some other frequency. Selection of two speeds is dependent on application requirements.

Futronic VIII has two independently programmable acceleration rates—one is from stop to slow speed, and the other is from slow speed to normal speed. It also has two independently programmable deceleration rates—one is from normal speed to slow speed, and the other is from slow speed to a minimum frequency at which time the electric motor brake may be applied. Due to programmable motor acceleration and deceleration rates, Futronic VIII can provide control precision of better than 0.25% accuracy in most applications, even at operating times of 10 seconds.

VFC must be mounted in a separate enclosure within 150 meters (500 ft) of the actuator. Refer to the TEC2000 Installation & Operation Manual, E2K-405-0703, for programming instructions.

- Accuracy:  $\pm 0.25\%$
- Bandwidth: 0.1% to 5%, adjustable in 0.1% increments (default: 2%)
- Speed bandwidth: 0.5% to 9%, adjustable in 0.1% increments (default: 5%)
- Delay time: 0 to 60 seconds, adjustable in 0.25 second increments (default: 1.0 second)
- Input impedance: 250 ohm
- Input polarity: (Selectable) 4mA = Close or 20mA = Close (default: 4mA = Close)
- Output polarity: (Selectable) – 4mA = Close or 20mA = Close (default: 4mA = Close)
- Loss of signal: Selectable to Fail open, Fail close, Fail to preset position, or Stay Put in last position (default)

### D) Three-Wire Analog Position Controller – Futronic II, IV or VIII

This feature, if selected during Setup, provides a means for backup control in case of loss of analog input signal. It allows a valve to be controlled as normal from a 4-20mA input signal, but with the possibility of this input signal being overridden by discrete digital inputs in the OPEN or the CLOSE direction, or in both. Discrete inputs may be used to operate the valve on loss of analog signal. As soon as digital signal is removed, actuator returns automatically to its normal analog mode.

### Remote Display Module (RDM) (Optional) Patent Pending

The RDM is an exclusive control and display module, available only from EIM, that puts TEC2000's non-intrusive controls within easy reach, no matter where the actuator is installed. It has display capabilities identical to those of the Local Display Module (LDM), and it can perform the same control, configuration, and diagnostic tasks. Two RDMs can be networked with a single actuator at a distance up to 1200 meters (4000 ft) from actuator, and each can perform the same control, configuration, and diagnostics tasks as the local controls on the actuator. Applications include typical situations in which a valve is in an inaccessible location (e.g., down in a pit or high up in the plant, or outside the wall on a tank storage facility) where access to valve might be dangerous in the event of a fire or leakage of fumes.

The RDM communicates with the actuator via an RS-485 communication link and a single twisted-pair cable.

**Table 1: Typical Cabling Requirements**

RDM	Function	Cable Type (Belden or equivalent)
AC-RDM	AC Supply – 115/230V, 50/60Hz	0.6 mm <sup>2</sup> (20AWG) or larger
	RS-485 Data Connection	Belden 9841 or equivalent
DC-RDM	DC Supply – 24V from Actuator	Belden 8719
	RS-485 Data Connection	Belden 9841 or equivalent

**Figure 3: Remote Display Module (RDM) (Patent Pending)**

TEC2000's remote display module (RDM) allows convenient ground-level operation of inaccessible actuators.



The RDM also enables full valve control at a safe distance in hazardous environments or during emergencies.

#### **Priority of control between LDM and RDM:**

The RDM module is in continuous communication with the central processor in the actuator. Remote control from the control room is only possible if all selector switches are in REMOTE mode. As soon as any selector switch is placed in LOCAL mode, then local control can be achieved at that position. If any of the selector switches are placed in STOP mode, neither local nor remote control will be possible. Any one of the selector switches may be padlocked in STOP mode to prevent control from other locations (*i.e.*, lock-out, tag-out).

#### **Power requirements:**

A single RDM can be powered via internal 24VDC supply from actuator.  
One or both RDMs can be powered from an independent 115/220V ac power source.

Current draw per RDM: 200mA @ 24VDC

150mA @ 115VAC (no heater), 260mA @ 115VAC (with heater)

110mA @ 230VAC (no heater), 220mA @ 230VAC (with heater)

## INDICATION & MONITORING

### LOCAL INDICATION

The IconoText screen displays alarm symbols, mode of operation, valve status, valve position, and torque output throughout the valve travel. Its message center comprises two lines of text, 16 characters per line, and displays actuator setup selections, data entry feedback, actuator status, diagnostic data and alarm messages. Text messages are in English language, as standard, but a simple software program is available from EIM that permits users to configure and download their own text in a variety of languages (using Roman alphabet plus limited Greek alphabet, plus limited graphics).

The following alarms are available to be displayed, if active:

<b>Electronic Fault Monitor</b>	<b>Valve Drift (handwheel)</b>	<b>Open Inhibit</b>	<b>Lost Analog Signal</b>
Open Torque XX%	Power Fail	Close Inhibit	Actuator Fail
Close Torque XX%	Lost Phase	Local ESD	Setup Error
Valve Stalled	Motor Overload	Remote ESD	Set Limits before Operating

LEDs (red, green, and yellow) on Local Display Module (LDM) indicate the following status and alarm functions:

**Table 2: Alarms**

<b>Valve Activity</b>	<b>Display Function (LEDs)</b>		
	<b>Red</b>	<b>Green</b>	<b>Yellow</b>
Fully Close	OFF	ON	OFF
Opening	Flashing	OFF	OFF
Stopped	OFF	OFF	ON
Fully Open	ON	OFF	OFF
Closing	OFF	Flashing	OFF
Alarm	OFF	OFF	Flashing

Default functions for CLOSE (green) and OPEN (red) are as shown. Alternate functions for CLOSE (red) and OPEN (green) can be programmed in the field or prior to shipment (if specified at time of order).

Adjacent to the LEDs is the IrDA transmitter/receiver that permits the Clicker device or PC/PDA to communicate with the actuator, without the need for interconnecting cables or opening the enclosure.

Figure 4: LCD Display (all icons are displayed for reference in illustration)

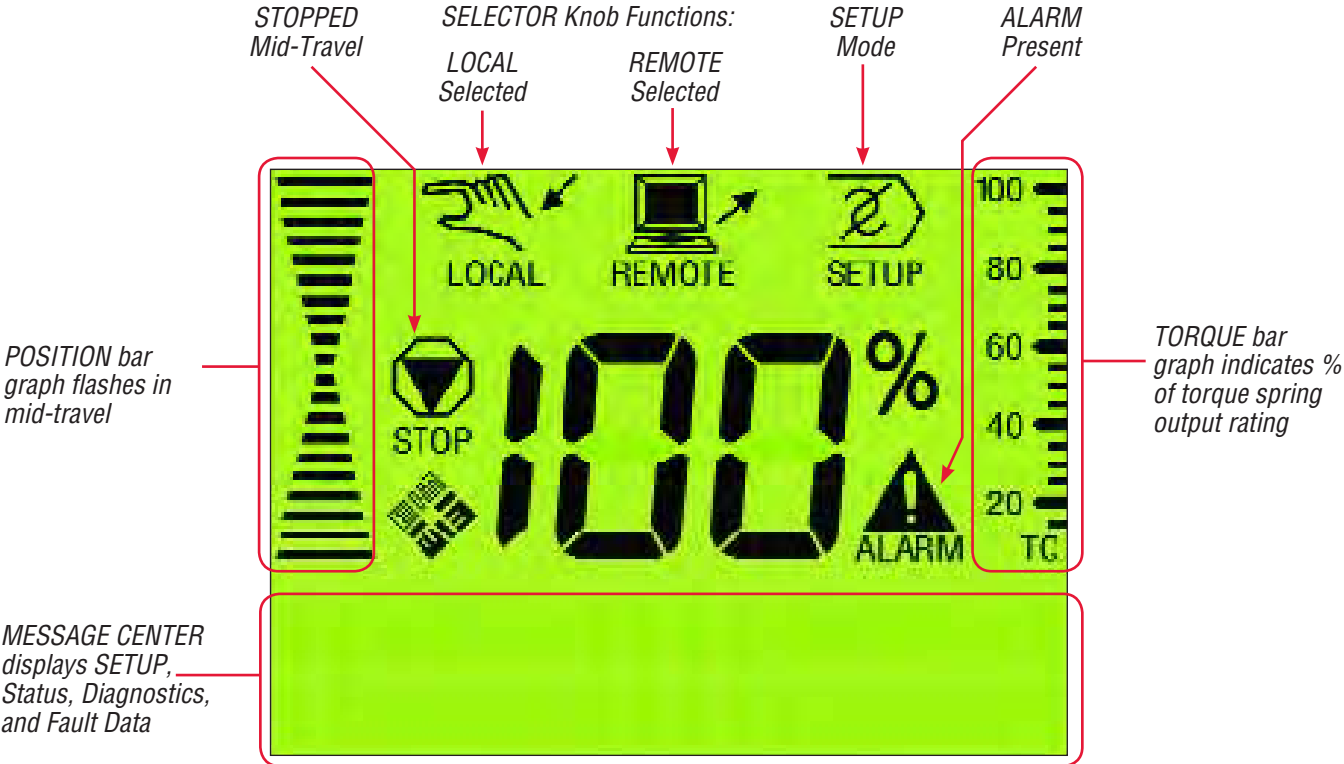

TEC2000 ICONOTEXT DISPLAY showing actuator in LOCAL mode and valve in full close position.



TEC2000 ICONOTEXT DISPLAY showing actuator in SETUP mode and valve 82% OPEN.

## REMOTE INDICATION

### Standard Relay Contacts

TEC2000 is supplied, as standard, with four latching volt-free contacts that provide remote feedback of actuator status. Each contact can be independently configured for normally open, normally close or flashing (1 second interval) mode.

Contact rating: 5A @ 30VDC, or 5A @ 250VAC resistive, or 2A @ 250VAC inductive

Relay output function can be configured from a wide range of options (see **Table 5**). Default settings are:

**Table 3: Relay Output Functions (Default Settings)**

Relay	Default Function	Default Setting
RO #1	Valve Full Open (LSO)	Normally Open Contact
RO #2	Valve Full Close (LSC)	Normally Open Contact
RO #3	Intermediate Valve Position (LSA)	Normally Open Contact
RO #4	Intermediate Valve Position (LSB)	Normally Open Contact

**NOTE:** RO #3 and RO #4 can be configured as LSO and LSC. Default LSA and LSB can be set anywhere between 0 – 100%.

### Auxiliary Relay Module (ARM)

Optional ARM module provides four additional latching volt-free contacts for status or alarm indication. These contacts are independently configurable for normally open, normally close or flashing (1 second interval) mode as well as a wide range of optional functions (see **Table 5**). The default settings are:

**Table 4: Auxiliary Relay Module (ARM) (Default Settings)**

Relay	Default Function	Default Setting
RO #9	Lost Power	Normally Open Contact
RO #10	Motor Overload	Normally Open Contact
RO #11	Lost Phase	Normally Open Contact
RO #12	Over Torque	Normally Open Contact

All relay output contacts—RO #1 to 4 and RO #9 to 12—can be configured to signal any one of the functions listed in the table below.

**Table 5: Relay Output Function Options**

LSO – Open Limit	LSC – Close Limit	Opening	Closing
Moving – Open or Close	Selector in “Local”	Selector in “Stop”	Selector in “Remote”
LSA – Mid-travel Position “A”	LSB – Mid-travel Position “B”	Open Inhibit Signal Present	Close Inhibit Signal Present
Local ESD Signal Present	Valve Operated Manually	Over Torque – Open or Close	Generic – Controlled by Network
Motor Overload	Open Torque Limit	Close Torque Limit	Electronic Fault Monitor
Valve Stall	Actuator Fail	Lost Phase	Lost Power
ESD Active	Lost Analog Signal	Low Battery	

## MONITOR RELAY

Monitor relay (RO #5) indicates whether actuator is “available” for remote control and is energized when conditions are normal. Relay will de-energize should any of the following events/faults occur in actuator:

- Selector switch in “Local” position
- Selector switch in “Stop” position
- Torque switch tripped in mid-travel
- Loss of internal control power
- Electronic fault monitor
- Motor overload trip
- Loss of one or more phases of the incoming power supply
- Valve stall

Monitor relay has one normally open and one normally close contact. It resets automatically as soon as the event/fault is corrected.

Contact rating: 5A @ 30VDC, or 5A @ 250V ac resistive, or 2A @ 250VAC inductive

## ANALOG FEEDBACK

### Analog Valve Position Feedback (VPF)

A non-contacting 4-20mA analog output signal is available for continuous remote position feedback of valve position. Output can be powered from actuator’s internal 24V dc supply, or externally from a remote 24VDC power source.

Repeatability:	±1%
Linearity:	±2% of total valve travel
External impedance:	250 ohms nominal (1000 ohms maximum)

### Analog Valve Torque Feedback (VTF)

A non-contacting 4-20mA analog output signal that is proportional to actuator output torque (15% to 100%) is available for continuous remote torque feedback as valve is being operated in both directions of travel. VTF output can be powered from the actuator’s internal 24VDC supply or externally from a remote 24VDC power source.

Repeatability:	±1%
Linearity:	±2% of maximum output torque
External impedance:	250 ohms nominal (1000 ohms maximum)

**NOTE:** VTF output can be used in conjunction with a suitable software program to provide “torque profiling” for the valve and, subsequently, be used for predictive maintenance purposes, since an increase in torque required to operate valve may indicate that valve is wearing, corroding, etc.

## DIAGNOSTICS & HISTORICAL DATA

Diagnostic and historical data about the actuator can be viewed at any time, without entering a password, by accessing display diagnostics through the message center on the LDM (Local Display Module). The following data is available for viewing or downloading to a PDA or PC:

### **Alarm Log**

- See list in **Table 2, Page 10**. Display lists last nine alarms that have occurred. List progresses from most recent to oldest alarms received.

### **Torque Profile**

- Torque data is recorded at 10% intervals of valve travel throughout the last stroke in both open and close directions, expressed as a percentage of maximum output torque of the spring installed in the actuator. The first display indicates “pullout” torque, which is the peak torque recorded in open direction from 0 to 9% of travel while unseating valve. Subsequent displays scroll through the recorded data, two positions at a time.

### **Torque Archive**

- Torque archive is data stored at a time initiated by user while in “Valve Control Setup” mode. It would typically be at the time that the actuator was initially installed on valve or after valve had been re-conditioned, or a similar notable event.

### **Operation Log**

- This log provides data that might assist with troubleshooting. It contains the operation details accumulated since it was last reset. Data displayed:
  - Motor Starts (number of times the motor has been started)
  - Number of Strokes (number of full strokes from limit to limit)
  - Motor Run Time (total motor operational time)
- This log can be reset to zero by entering the “Change Settings” mode.

### **Operation Archive**

- This log provides same data as Operation Log but accumulated data is from initial commissioning of actuator and, therefore, gives a full history for actuator.
- This log cannot be reset by user. It is intended to be reset only by qualified EIM personnel after a major overhaul of actuator.

### **Hardware**

- This display reports status of modules and can identify which module is at fault if a problem exists with the actuator. Hardware status report can indicate whether module is:
  - Normal
  - Not Configured
  - Lost Link
  - Failed
- Hardware displays provide data on:
  - Electrical compartment temperature (°C)
  - APD (Absolute Position Detector)
  - Central Control Module
  - Local Display Module
  - Remote Display Module #1
  - Remote Display Module #2
  - Analog Module
  - Network Module
  - EFM (Electronic Fault Monitoring) Module

# PROTECTION FEATURES

## MOTOR PROTECTION

Inherent thermal overload sensors are embedded in motor stator winding to protect the actuator motor from overheating. Sensors open if temperature exceeds 130°C for T4 or 115°C for T4A, and de-energize reversing contactor (or solid-state starter) to remove power to motor. Motor protection can be overridden by an ESD signal, if so configured during Setup. Local and remote indication of Motor Overload is provided.

Additional motor protection (optional) can be provided by use of overload relay with bimetallic current sensor to match motor current. (Refer to page 19 for additional information.)

## AUTOMATIC PHASE DETECTION & CORRECTION

Phase monitor ensures that the actuator motor rotates in correct direction regardless of how three phases have been connected to actuator terminals—thereby reducing risk of damage to valve during start-up due to incorrect phasing. It continuously checks incoming supply and shuts down reversing contactor if one or more of the phases is lost; it will also prevent actuator from starting if one phase is missing. Local and remote indication of a lost phase (single-phasing) is available.

## TORQUE PROTECTION

TEC2000 retains the established and reliable technology of measuring actual torque load by the sliding worm method that has served for over 50 years in all applications and climates. Movement of the worm against a calibrated set of precision disc-springs rotates a gear; the rotation is converted to an electronic signal by Hall-effect sensors. This direct-sensing method provides accurate and reliable torque monitoring over the life of the actuator in all environments. Since no fragile transducers are used in the motor, and no complex algorithms involving motor speed are used to estimate torque being developed, there is no need for specially constructed or specially wound motors. This permits EIM motors to be replaced or rebuilt by local motor repair facilities and avoids the need for costly new motors to be purchased.

Torque sensors for open and close direction can be adjusted independently in the range 15 – 100% of rated torque range of spring stack installed in actuator.

Output torque or speed of operation can be easily modified in the field by changing gear ratios, spring stacks, or motor sizes. No complicated reprogramming of torque processors is necessary, thereby providing the highest degree of flexibility for the customer.

## JAMMED VALVE PROTECTION

In the event that the valve is stuck in its seat and the actuator is unable to unseat it, a jammed valve will be detected and the actuator motor will be de-energized if no movement is detected within 10 seconds. Further electrical operation will be prohibited until the problem is cleared, usually requiring manual operation of the valve or essential maintenance to be carried out. Local and remote indication of a valve stall condition is available.

## LOG-JAM PROTECTION

If torque demanded by the valve in mid-travel, in either direction, exceeds value configured by the valve supplier, the TEC2000 will automatically de-energize the actuator motor and deduce that there may be an obstruction in the valve. It will then automatically reverse direction of travel for 1.0 second and retry to overcome the obstruction three times. This will provide an opportunity for the obstruction to be cleared by flow of pipeline medium but, if unsuccessful, further electrical operation will be inhibited until the problem is cleared. This may simply require torque configuration to be increased in Valve Control Setup due to changes in process parameters or wear/corrosion in the valve that have affected torque requirement. This feature can be switched off in Valve Control Setup, if not required. Local and remote indication of over-torque is available.

## MOTOR REVERSAL PROTECTION

It is possible to reverse direction of travel, in both local and remote modes, without first issuing a Stop command. An automatic time delay of 0.5 seconds occurs on reversal of signal to protect actuator motor and reversing contactor against damage due to high surge currents and inertia.

# ELECTRICAL SPECIFICATION

## POWER SUPPLY OPTIONS

TEC2000 actuators are available for three-phase (three-wire) and single-phase power sources:

### ***Three-phase 50Hz***

220, 230, 240, 380, 400, 415, 440, 460, 480, 500, 550, 575, 600, and 690 volts

### ***Three-phase 60Hz***

208, 220, 230, 380, 440, 460, 480, 575, 600, and 690 volts

### ***Single-phase 50Hz***

110, 115, 220, 230 and 240 volts

### ***Single-phase 60Hz***

115, 120, 208, 220 and 230 volts

The nominal operating voltage must be specified at time of order. Published actuator performance data is for power supply variations of  $\pm 10\%$  voltage and  $\pm 5\text{Hz}$  frequency. If power supply variations are outside of these limits, please consult EIM to ensure that actuator performance meets your requirements.

## MOTOR

Design of electric actuators so that they are suitable for operation of valves, dampers and similar applications starts with selecting the correct motor. Valve designs possess a specific set of load characteristics that vary from manufacturer to manufacturer, so it is important to have a motor design that can exceed these loads in all environments. It is also important that actuator motors are designed and constructed in accordance with international standards and practices, so that they are capable of being serviced by local motor repair facilities throughout the world.

Heavy-duty valve actuators manufactured by EIM are typically used in areas where three-phase AC power supplies are readily accessible. For these applications, EIM utilizes Class F insulated, 15-minute duty rated, 4-pole motors with inherent thermal overload protection via thermostats embedded in the stator winding (limited to Class "B" temperature rise). These motors are designed specially for a higher pull-up (starting) torque, providing a torque curve that closely mimics load requirements of a typical valve. Motors for special services (such as large sluice gates/penstocks that require high running loads, or modulating duties that require frequent operation) are also available.

Motors rated for standard 15-minute duty are suitable for up to 100 starts/hour. Motors for positional control and modulating duty are available for operating at rates up to 1200 starts/hour, in association with our Futronic position controllers.

An optional space heater for the electric motor is available for specific applications.

## INTERNAL POWER SUPPLY

TEC2000 provides a regulated 24VDC power supply for powering discrete and analog inputs and outputs, if needed by the user.

Maximum capacity: 500mA peak, 300mA continuous.

## FUSES

Fuses complying with N.E.C. requirements, are located in the Separate Terminal Chamber (STC) instead of in the electric control compartment, thereby maintaining sealed integrity of the actuator should a fuse need replacement due to external cabling faults. (Having these user-replaceable fuses in the STC avoids the need to access the electronics control compartment, which could void the warranty.)

Secondary fuses (three) are solid-state, auto-reset type. Simply clearing the fault will allow fuses to reset.

## SPACE HEATER

TEC2000 is fitted with a 12W space heater inside controls compartment to protect against condensation due to temperature cycling that might occur, especially overnight in some environments. Heater has solid-state thermostatic control which removes power from heater if compartment's internal temperature exceeds 45°C (113°F).

## PATENTED ABSOLUTE POSITION DETECTOR (APD)

(Patents 6,424,928; 6,577,985; 6,615,156)

The APD is a non-contacting position encoder with a minimum life of 50 million actuator drive shaft revolutions. It is geared mechanically to the worm drive of the actuator and remains in step with valve position regardless of operation from motor or handwheel. It controls open and close valve positions and provides local and remote position feedback. It does not require battery back-up of any kind to maintain calibration during loss of power to actuator. Calibration of the APD is achieved without removing control cover. (See **Setup Options, page 4**, for configuration methods.)

## TORQUE CONTROL

Torque control is used to stop travel of valve, or other device, if output torque of the actuator reaches a preset amount. Torque sensing is achieved by measuring actuator output via a non-contacting transmitter. The torque switches are independently adjustable in the range from 15% to 100% of rated actuator torque spring stack. Adjustment of the output torque can be achieved without removing the control cover.

## DISPLAY BACK-UP MODULE (DBM)

A display back-up module, containing up to two 9V Lithium batteries (Ultralife U9VL must be used), can be installed to provide power to the LCD display in the event of loss of main power source to actuator. This option also enables manual operation to be detected during power outages, and enables any change of status to be signaled back to the control room by resetting latching-type relays. (DBM will not support functioning of optional RDM during this time.)

With DBM installed, the actuator can also be calibrated on the valve without applying main power supply, and changes to configuration can be made in Setup mode.

In order to extend battery life, the DBM is supplied, ex-factory, with battery disconnected. Simply insert a jumper strap between terminals 36 and 38 of the STC (Separate Terminal Chamber) to connect battery to electronic circuits.

**NOTE:** Batteries are not required to maintain any data or valve position during a power outage, because all configuration settings are saved in non-volatile memory, and because position detector is an “absolute” encoder which cannot lose calibration under any circumstances. TEC2000 does not use any “incremental” encoders, since these are unreliable in a power outage.

## CIRCUIT BREAKER/DISCONNECT SWITCH MODULE (CBM)

EIM offers circuit breaker/disconnect switch for TEC2000 to interrupt circuit between actuator and incoming power supply—thereby ensuring safety during field maintenance and repair. Breaker is mounted in a separate electrical compartment, called the CBM (Circuit Breaker Module), that can be close-coupled to actuator or mounted to a wall, panel, pipe, etc.

## MOTOR CURRENT OVERLOAD RELAY (MCR)

An auto-reset overload relay can be provided inside control compartment (in addition to inherent thermal overload protection supplied as a standard in all EIM actuators by way of thermostats embedded in the motor stator windings). The motor overload relay is a time/current device that senses current in all three windings of the three-phase motor, and trips within 10 seconds if current remains six times the current setting. It automatically compensates for varying ambient temperature to ensure consistent trip performance.

**Figure 5: Circuit Breaker/ Disconnect Switch Module (CBM)**



## SEPARATE TERMINAL CHAMBER (STC) – CABLE TERMINATIONS

TEC2000's STC (Separate Terminal Chamber) is isolated from the controls compartment and incorporates a watertight seal to ensure that no dampness or dust is allowed into electronics when terminal cover is removed for cabling. A separate terminal chamber is one of the defining features of TEC2000 actuators, and the design of TEC2000's STC offers several very distinct advantages:

- Cover is threaded instead of bolted, for easy access.
- Terminal block has highly visible labeling for every connection to help avoid field-wiring errors. A separate termination card inside the cover is not necessary.
- Terminal screws are already installed for fast and easy cable terminations. Terminal block connectors are wire-binding screw connectors with rising captive plates. Connections can be made in three ways:
  - Bare wires
  - Wire ferrules
  - Crimp-on insulated or non-insulated ring or spade/fork-tongue connectors
- User-replaceable primary transformer fuses are located in the STC, thus avoiding the need to open controls compartment to gain access to them. Secondary fuses are solid-state, self-resetting type.
- Four conduit entries, as standard, provide convenient wiring paths.

All conduit entries are fitted with metal NPT plugs, ex-factory, but it is the responsibility of the user to ensure that correct adapters and glands are fitted in order to comply with the hazardous area certification requirements of their national authority.

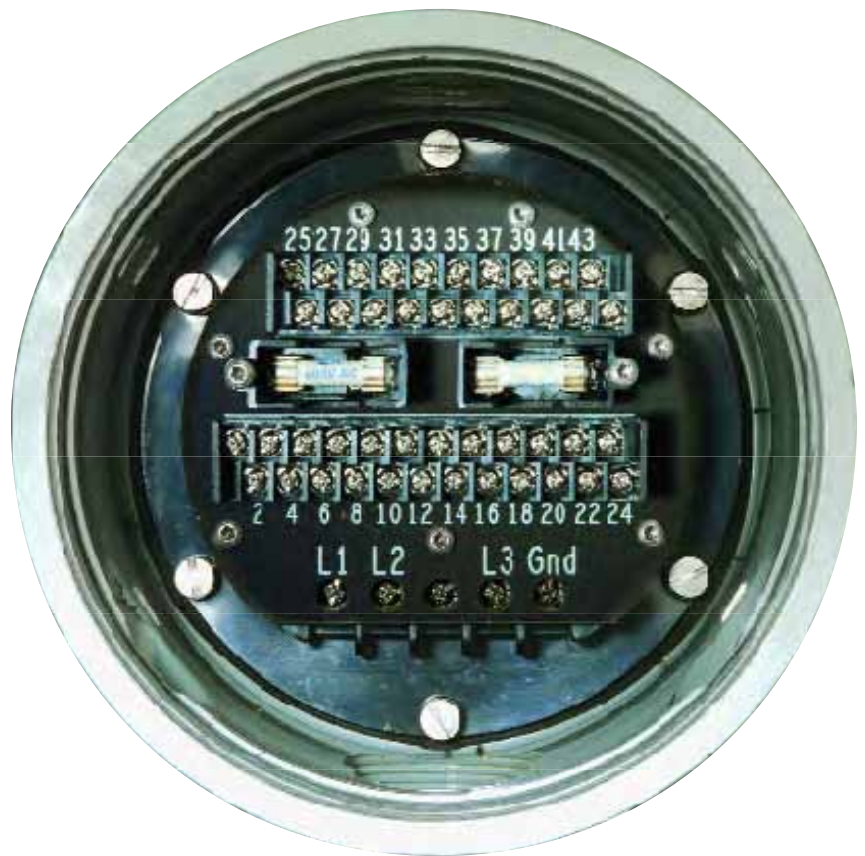

**Figure 6: Separate Terminal Chamber (STC) with Spade Lug Data**

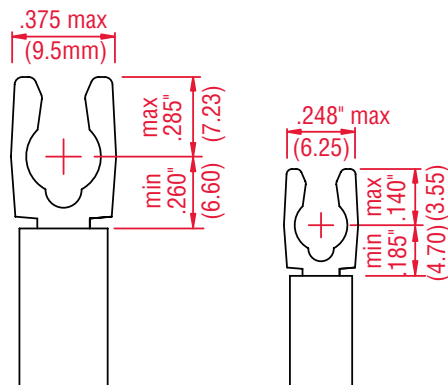

**Power Wiring**

- AMP 52936-2 (Blue)  
Wire Size 16-14
- AMP 52942 (Yellow)  
Wire Size 12-10

**Control Wiring**

- AMP 52929 (Red)  
Wire Size 22-16
- AMP 52935 (Blue)  
Wire Size 16-14

<b>Control Wiring</b>	<b>AMP</b>	<b>52929</b>	<b>52935</b>
	Wire Size	22-16	16-14
	Wire Insulation Max. Diameter	.125	.170
	Color	Red	Blue

<b>Power Wiring</b>	<b>AMP</b>	<b>52936-2</b>	<b>52942</b>
	Wire Size	16-14	12-10
	Wire Insulation Max. Diameter	.182	.250
	Color	Blue	Yellow

**NOTE:** Shown with wiring cover removed.

**Note:** Conduit entry sizes - Two 1" NPT, one 1.5" NPT bottom entry; one 1" NPT top entry. Adapters and reducers to suit Metric, PG and NPT can be supplied.

## ENCLOSURE CERTIFICATIONS

### WEATHERPROOF/WATERTIGHT PROTECTION

All actuators are supplied with a watertight and dustproof enclosure rated NEMA 4, 4X, 6, and 6P, and certified for temporary submergence to IP68 for 15 meters (50 ft. head) for 7 days.

### AMBIENT TEMPERATURE RANGE

Standard:	- 20° C to + 60° C (- 4° F to + 140° F)
Optional:	- 50° C to + 70° C (- 58° F to + 158° F)
Storage Temperature:	- 60° C to + 80° C (- 76° F to + 176° F)

### EXPLOSIONPROOF PROTECTION

Where actuators are required to be installed in hazardous areas, the TEC2000 is certified to the following explosion proof standards:

#### European (ATEX – 94/9/EC) Certification; Cenelec Norm EN50014 and EN 50018

- EExd IIB T4. ATEX II 2G
- EExd IIB + H2 T4. ATEX II 2G
- EExd IIB T4A. ATEX II 2G
- EExd IIB + H2 T4A. ATEX II2G

#### USA (Factory Mutual) Certification; NEC Article 500

- Class I, II and III, Groups C, D, E, F, G, Division 1, T4
- Class I, II and III, Groups C, D, E, F, G, Division 1, 120° C (T4)
- Class I, Group B, Division 1, T4  
(Not available for CBM – Circuit Breaker Module)

#### Canada (Canadian Standard Association) Certification

- Class I, II and III, Groups C, D, E, F, G, Division 1, T4
- Class I, II and III, Groups C, D, E, F, G, Division 1, 120° C (T4)
- Class I, Group B, Division 1, T4  
(Not available for CBM – Circuit Breaker Module)

#### Australia (Testsafe) Certification

- EExd IIB T4
- EExd IIB + H2 T4
- EExd IIB T4A
- EExd IIB + H2 T4A

## CORROSION PROTECTION

Standard corrosion protection for TEC2000 actuators is a TGIC polyester powder coating, which is suitable for the majority of applications, including marine and chemical environments. This thermosetting powder coating system meets Military Specification MIL-C-24712 and is approved by Underwriters Laboratory under listing UL 1332.

Each external component is shotblasted to remove oxidation, light surface oils, and to provide a light profile for increased adhesion, then pre-heated with SOLUCOAT 5039 (2.5 to 3%) at 65 °C (150 °F) for two minutes—this crystalline conversion coating (iron/phosphate) increases paint adhesion and prevents under-paint corrosion. Each component is then rinsed to remove any chemical residue and emulsified grease/oil, before being heated again and sealed with SOLUCOAT 5038 at 65 °C (150 °F) to provide the corrosion resistance required. Each part is then hot-air dried at 200 °C (400 °F) and immediately powder coated.

Film thickness:	65 – 90 µm (2.5 – 3.5 mils)
Salt spray test:	1000 hours
Color:	Haze Gray (similar to RAL 7042 or BS4800-18B21)

All external and internal fasteners and brackets are 316 stainless steel. Printed circuit card interconnects have gold-plated connectors. All these features provide the actuator with superior corrosion protection.

## OPTIONAL COATING SYSTEMS

For applications where there is a severely corrosive atmosphere, EIM offers alternative coating systems that have proved highly successful in marine and chemical applications where actuators are installed inside ship hulls or on deck, in water intake tunnels and water treatment plant clarifiers, in areas subject to salt-spray, etc. Please refer to EIM for specific applications.



*Figure 7: TEC2000 “R” Actuator*

## TEC2000 SECTIONAL VIEW & FEATURES

Figure 8: Cutaway view of the TEC2000

① **Superior Corrosion Protection**

*Polyester powder-coating, inside and out, for superior corrosion protection in all environments.*

*316 stainless steel cover screws for added corrosion protection and ease of maintenance over life of unit.*

*Marine-grade, low copper content, aluminum provides compartment and covers with extra corrosion protection.*

② **Separately Sealed Terminal Chamber**

*Separate Terminal Chamber (STC), dual sealed, allows installation wiring to be performed without exposing electronic control components. STC contains primary fuses for easy replacement. (See page 42 for optional position.)*

③ **Anti-Condensation Space Heater & Thermostat**

*Space heater prevents internal condensation due to temperature cycling. Solid-state thermo-statically controlled to turn heater off at 105°F, 40°C (internally mounted).*

④ **IconoText LCD Message Screen**

*Large LCD panel uses icons and text to display status of valve and provide diagnostic data. Message center guides operator through calibration, setup, and diagnostics using easily understood text. Language is user-configurable.*

⑤ **Non-Penetrating Control Knobs**

*Local control knobs are non-penetrating and operate vibration resistant Hall-effect switches to enable actuator calibration and diagnostics without opening covers. Local/Stop/Remote selector switch can be padlocked in any position.*

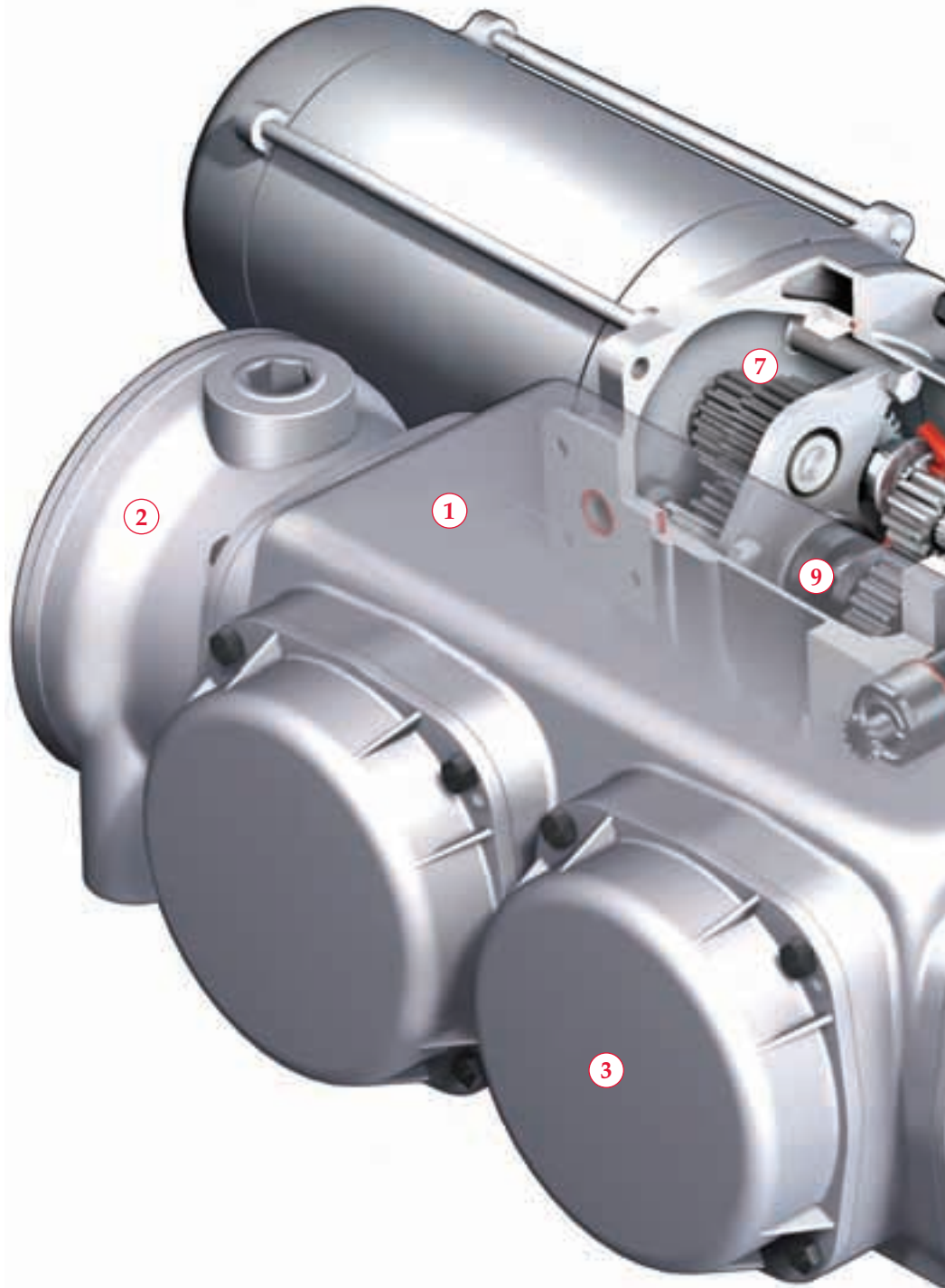



- 6 Local Display Module (LDM)**  
LDM can be rotated in 90-degree steps or moved to adjacent location for optimum viewing position. (See page 42 for optional position.)

- 7 Double-Reduction Motor Gears Provide Flexibility**  
First stage spur gearing provides flexibility of motor and speed selection. Enables worm gearing to operate at lower speeds for minimum wear and long life.

- 8 Low Declutch Forces**  
Declutch lever requires low force to operate. Can be padlocked in Hand or Motor mode.

- 9 Hand/Auto Clutch *EIM EXCLUSIVE***  
Clutch operates on low torque side of worm gear drive. Automatic motor priority.

- 10 Main Housing *EIM EXCLUSIVE***  
Ductile iron gear-housing is robust and corrosion-resistant.

- 11 Bearing Supported Drive Shaft**  
Drive shaft is supported by heavy-duty tapered roller bearings—top and bottom—to provide long life and low wear of gearing and seals.

- 12 Self-Locking Gearing**  
Permanent self-locking gearing, even during declutching and manual override. Valve stem cannot be back-driven under high process pressures or heavy weight of gate.

- 13 Low Manual Override Forces**  
Low manual override forces with mechanical advantage of gearing on input to worm drive. 80-lb (350N) rimpull standard—lower forces available by changing gearing.

**Display Back-up Module**  
Optional battery back-up allows LCD to remain powered during electrical outages. Battery not required to maintain any data or position calibration (internally mounted).



*Figure 9: STC (Separate Terminal Chamber), LDM (Local Display Module), and CBM (Circuit Breaker Module) alternate mounting locations*

## CONTROLINC® NETWORK CONTROLS

Controlinc is EIM's generic name for the range of integrated digital control networks first introduced by EIM in 1985. The controller is specifically designed for valve control applications, either block valve or proportional valve (modulating) control. With auto-calibrating analog inputs as a standard feature, it automatically learns and adapts to any valve size and speed of operation.

Controlinc digital control networks can interface with several different network protocols through the use of a Communication Adaptor Module (CAM), and currently, Modbus, Foundation Fieldbus, Profibus, and DeviceNet protocols are supported. All networks offer real-time data acquisition, diagnostics and alarms.

### MODBUS RTU

EIM's standard protocol, in use since 1985, is Modbus RTU. All standard Modbus function codes are fully supported, including "Report by Exception" commands that enable the status of up to 100 actuators to be updated in less than two seconds. Up to 254 actuators can be installed in a single network, and the overall length of network cabling can be extremely long without degrading network performance or response time. Length of cable between each actuator, or between controller and first actuator in network, can be up to 1500 meters (5000 feet) and there is no need to use separate repeaters. Total network distance can be up to 320 km (200 miles).

Fully redundant networks comprising a serial loop topology are a standard feature, and no single cable fault, open-circuit, short-circuit, or ground fault will cause a loss of communication to any actuator. Hot-standby, redundant network masters are a standard option.

# MODBUS RTU

## Serial E>Net Redundant Loop Topology

- Two data paths to each device from network master
- Open-circuit and short-circuit protected
- Redundant cabling included
- Long cable distances can be installed
- Maximum distance between valves can be up to 1500 meters (5000 ft)
- Total network distance can be up to 320 km (200 miles)
- Maximum number of valves in network can be 254
- Redundant "hot-standby" network master option available

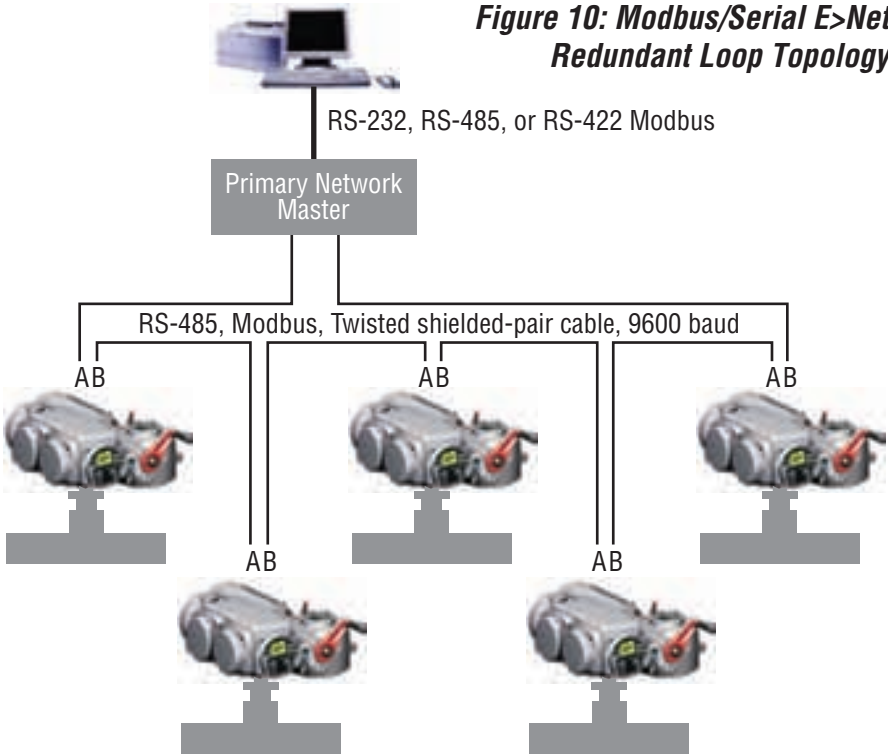

Figure 10: Modbus/Serial E>Net Redundant Loop Topology

## Multi-drop Bus Topology

- Only one data path to each device from network master
- No short-circuit or ground fault protection in network
- Open-circuit protection only to the first cable fault
- No redundancy included
- Maximum network cable length is only 1200 meters (4000 ft)
- Maximum number of valves in network is 32
- Repeaters required to extend the network

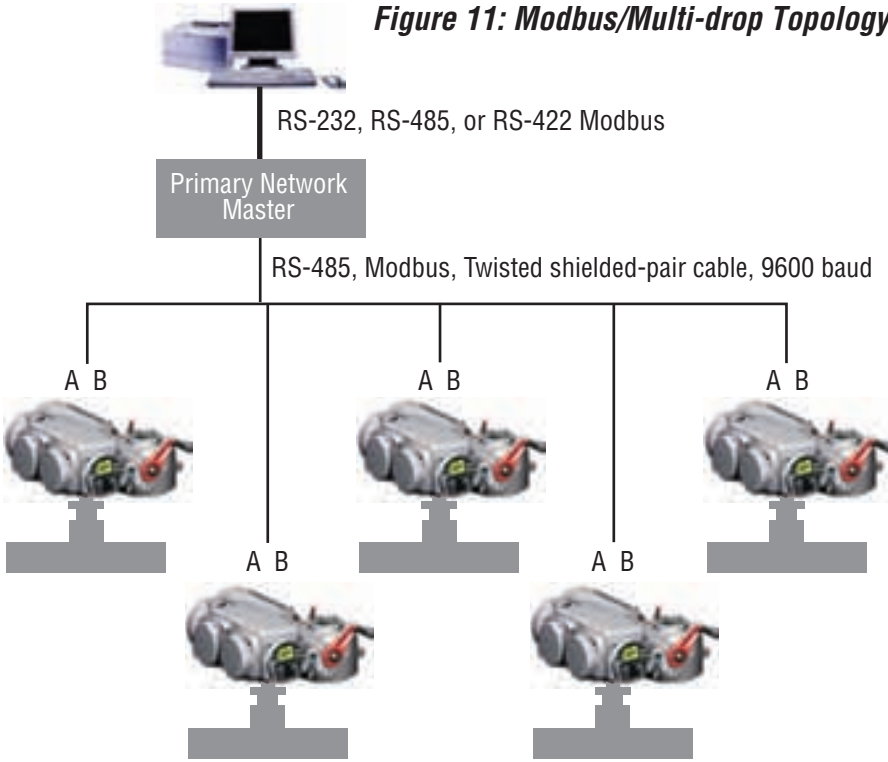

Figure 11: Modbus/Multi-drop Topology

## FOUNDATION FIELDBUS

TEC2000 actuators supporting Foundation Fieldbus H1 protocol are fully certified by the Fieldbus Foundation and provide direct connection to the fieldbus with guaranteed interoperability with other certified devices. Each network can comprise up to 32 devices, with power for devices being provided via network cabling (assuming intrinsically safe devices are not connected to the same network). Networks may extend up to 1900 meters (6000 ft) long, and repeaters may be used to extend the distance or to incorporate more than 32 devices.

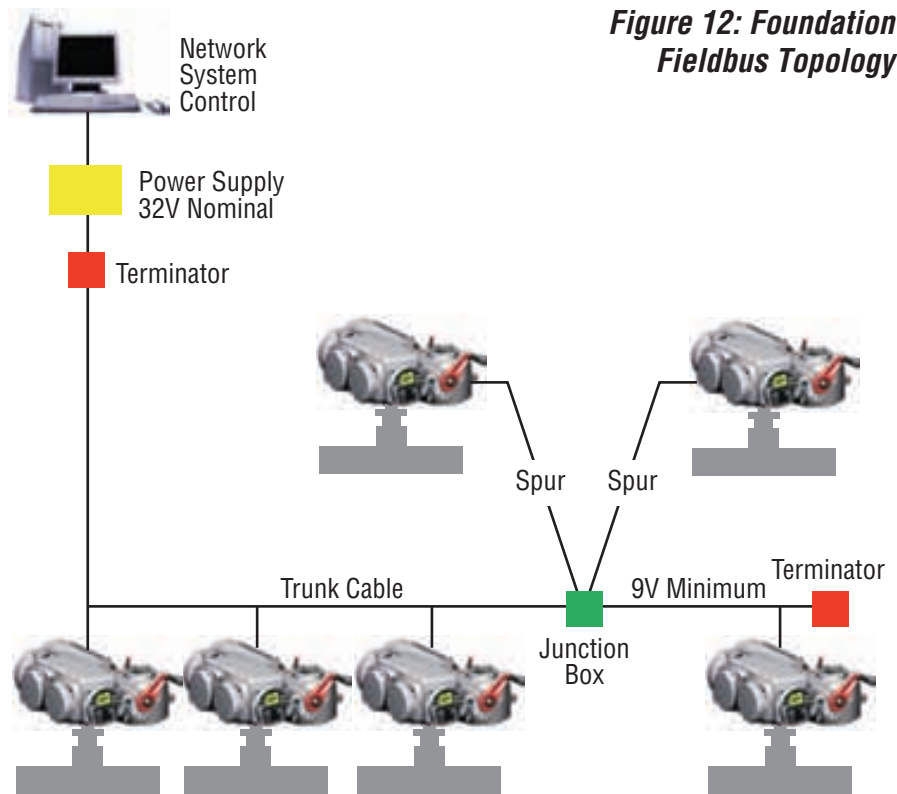

Figure 12: Foundation Fieldbus Topology

## PROFIBUS

Fitting TEC2000 actuators with a CAM-210 module allows valve actuator to be integrated into a Profibus DP network. Profibus DP protocol allows actuators to be integrated with transducers and other control equipment on the same network. Up to 126 nodes may be connected to one bus network, but network length is limited to 1200 meters (4000 ft), although repeaters may be used to extend the distance.

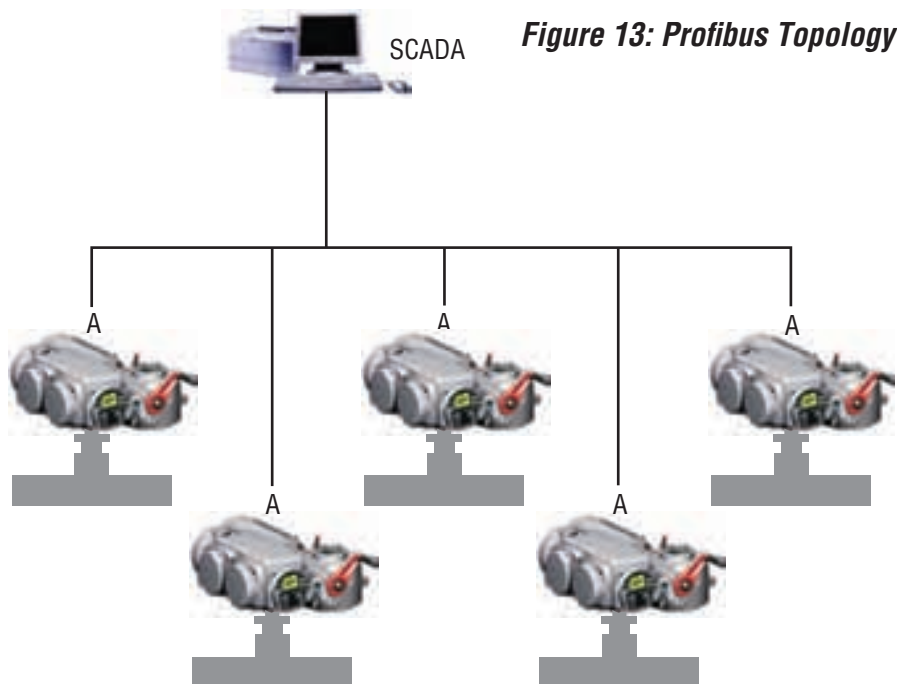

Figure 13: Profibus Topology

# MECHANICAL INTEGRITY

## MATERIALS OF CONSTRUCTION

EIM actuators are designed and built for years of dependable, trouble-free service in all operating environments.

Main gear housing:	High strength ductile iron, providing maximum strength and ductility
Control housing:	Marine-grade low copper aluminum
Motor:	Aluminum alloy end housings, steel casing and tie rods
Spur/Helical gearing:	High-strength alloy steel
Worm:	High-strength alloy steel (rolled, heat-treated and ground)
Worm gear:	Alloy bronze
Shafts – splined:	Steel
Bearings – thrust:	Tapered roller
External fasteners:	Stainless steel 316

## DRIVE MECHANISM

**Figure 14: Drive Mechanism**

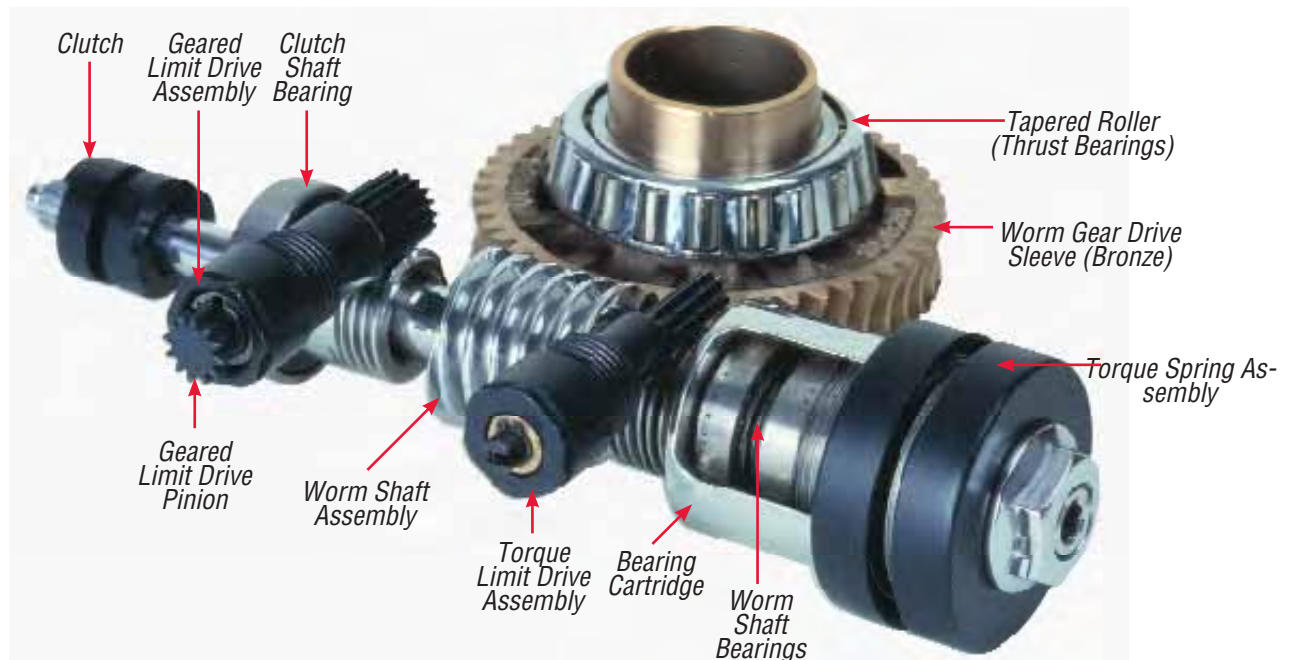

**Figure 15: Motor Gearing**



## **MOTOR GEARING**

- Double-reduction spur gearing on motor permits lower worm gear speeds, resulting in low wear and long life.
- Gearing provides flexibility in range of output speeds and easy changes in the field.
- All gearing is properly bearing-supported.

**Figure 16: Hand/Motor Declutching Mechanism**



## **HAND/MOTOR DECLUTCHING MECHANISM**

- Clutch Tripper: auto-declutch when motor starts.
- Handwheel gearing selected for 350N (80 lbs) maximum rim-pull or less, as required.
- Splined shaft for reliability and ease of declutching.
- Clutch ensures that handwheel cannot be rotated by motor.

**Figure 17: Hand/Auto Declutch Lever**



## **HAND/AUTO DECLUTCH LEVER**

- Low effort to change into manual mode.
- Can be returned to motor mode without starting motor.
- No “cheater bar” needed, even for tightly seated valves.
- Padlockable in either manual or motor mode.

**Figure 18: Manual Override**



## **MANUAL OVERRIDE**

- “Fold-up” spinner handle provides a compact profile.
- Gearing on input side of worm gear reduces rim-pull effort.
- Maximum rim-pull restricted to 350N (80 lbs) or less.
- Open/Close directional arrows

## PERFORMANCE DATA

Model Series	Max. Stem Size		Maximum Thrust		Maximum Torque		Output Speed (rpm)		Mounting Base	
	(inch)	(mm)	(lb)	(kN)	(ft-lb)	(Nm)	60 Hz	50 Hz	MSS	ISO

### Multi-Turn (Thrust & Torque)

1000	1.38	35	10,000	44	130	176	0-144	0-120	FA 10	F 10
2000	2.25	57	30,000	133	410	555	0-144	0-120	FA 14	F 14
3000	3.00	76	45,000	200	900	1,220	0-144	0-120	FA 16	F 16
4000	3.50	89	75,000	334	1,400	1,900	0-144	0-120	FA 25	F 25
5000	3.50	89	90,000	400	1,900	2,575	0-144	0-120	FA 30	F 30
6000-1	3.50	89	116,000	516	3,000	4,100	0-48	0-40	FA 30	F 30
6000-2	5.00	127	160,000	712	5,800	7,865	0-48	0-40	FA 36	F 35
6000-3	4.50	114	196,000	872	5,800	7,865	0-48	0-40	FA 36	F 35
7000	6.00	152	250,000	1,112	8,100	10,980	0-30	0-25	FA 40	F 40
8000	6.00	152	335,000	1,490	15,000	20,340	0-18	0-15	FA 40	F 40
9000	9.00	228	1,000,000	2,250	35,000	47,450	0-18	0-15	FA 48	F 48

### Multi-Turn (Torque Only)

D	1.25	32	-	-	300	410	0-250	0-208	FA 10	F 10
U	2.00	51	-	-	600	815	0-250	0-208	FA 14	F 14
S	2.00	51	-	-	1,900	2,575	0-200	0-167	FA 16	F 16

Model Series	Max. Stem Size		Maximum Thrust		Maximum Torque		Operating Time (sec)		Mounting Base	
	(inch)	(mm)	(lb)	(kN)	(ft-lb)	(Nm)	60 Hz	50 Hz	MSS	ISO

### Part-Turn (90° Rotation)

P	1.13	29	-	-	210	285	15-60	18-72	FA 10	F 10
Q	2.00	51	-	-	750	1,020	5-120	6-144	FA 12	F 12
R	3.25	82	-	-	1,500	2,035	15-360	18-432	FA 16	F 16
M/MG02	3.25	82	-	-	2,500	3,390	10-360	12-432	FA 16	F 16
M/MG03A	4.00	101	-	-	5,000	6,780	10-600	12-720	FA 30	F 30
M/MG03B	5.00	127	-	-	7,500	10,170	10-600	12-720	FA 30	F 30
M/MG05	6.00	152	-	-	15,000	20,340	15-900	18-720	FA 40	F 40
W/MG05	7.00	178	-	-	30,000	40,675	15-900	18-720	FA 40	F 40
W/MG07	8.00	203	-	-	70,000	94,910	45-900	45-720	FA 48	F 48

**NOTE:** EIM also offers quarter-turn actuators up to 365,000 ft-lb (500,000 Nm)

# OUTLINE DIMENSIONS

## DIRECT-MOUNTED STYLE - 1000, 2000, 3000, 4000, 5000, P, Q & R

FOR REFERENCE ONLY; use certified dimensions furnished with EIM job submittal.

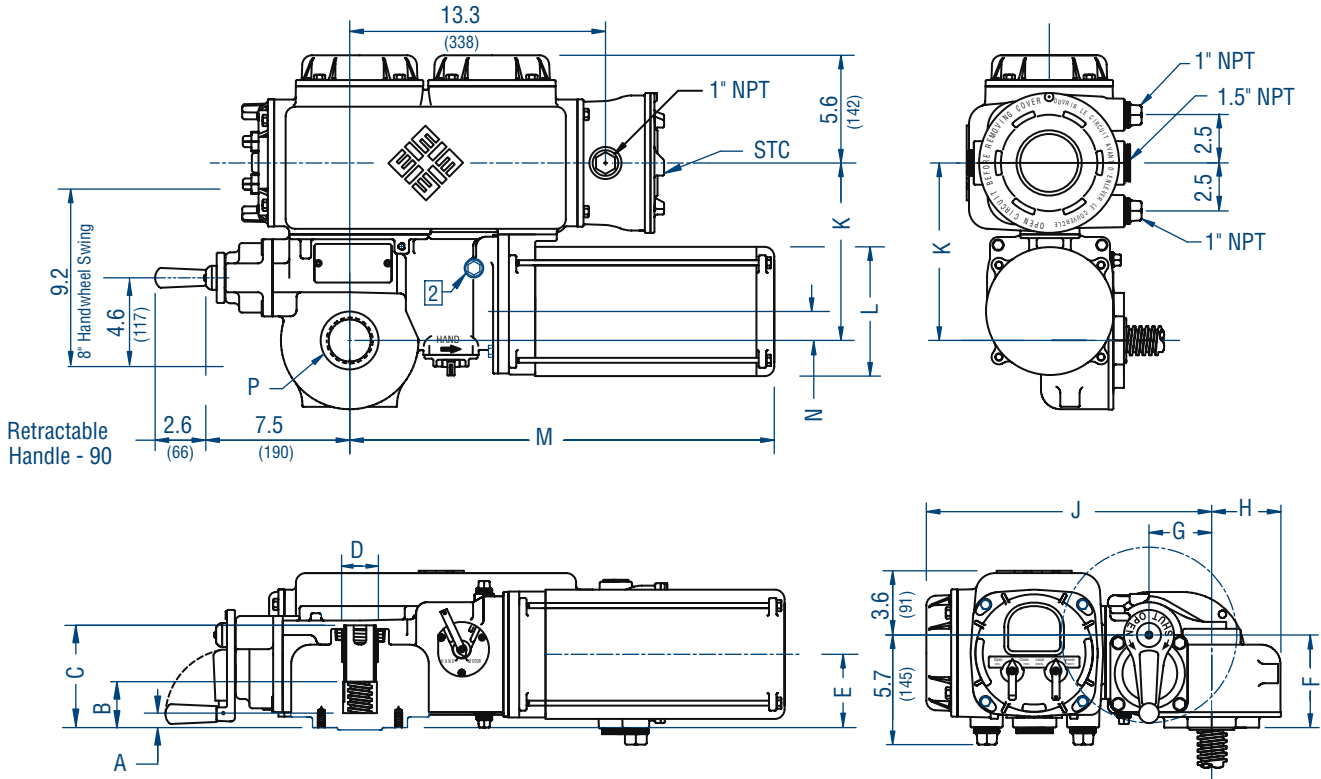

Model Size	Multi-Turn Actuators					Part-Turn Actuators				
	1000	2000	3000	4000	5000	P	Q	R		
	in.	mm	in.	mm	in.	mm	in.	mm		
A Bottom of Nut	0.75	19	0.65	17	0.95	24	0.60	15	0.60	15
B Top of Nut	2.38	60	2.90	74	4.50	114	4.20	107	4.20	107
C	5.30	135	7.80	198	8.60	218	15.10	384	15.10	384
D	1.43	36	2.80	71	3.15	80	-	-	-	-
E	3.80	97	4.70	119	5.20	132	10.90	277	10.90	277
F	4.80	122	5.70	145	6.20	157	11.90	302	11.90	302
G	3.25	83	3.25	83	4.25	108	4.25	108	4.25	108
H	3.60	91	3.60	91	4.30	109	5.80	147	6.90	175
J	14.80	376	14.80	376	15.80	401	19.20	488	19.20	488
K	9.20	234	9.20	234	10.20	260	11.10	282	11.10	282
L	6.70	170	6.70	170	6.70	170	10.00	254	10.00	254
M	22.00	559	22.00	559	22.00	559	30.00	762	30.00	762
N	1.50	38	1.50	38	2.50	64	2.50	64	2.50	64
P NPT	2"		3"		4"		4"		4"	

Mounting Base	FA10	FA14	FA16	FA25	FA30	FA10	FA12	FA16
MSS Std	FA10	FA14	FA16	FA25	FA30	FA10	FA12	FA16
ISO Std	F10	F14	F16	F25	F30	F10	F12	F16

- 1000, 2000 & 3000 units are referenced with 56 frame motors.
- 4000 & 5000 units are referenced with 215 frame motors.
- P, Q & R units are referenced with 33 frame motors

# OUTLINE DIMENSIONS

## DIRECT-MOUNTED STYLE / RISING STEM - 6000 & 7000

FOR REFERENCE ONLY; use certified dimensions furnished with EIM job submittal.

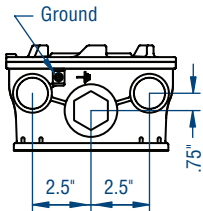
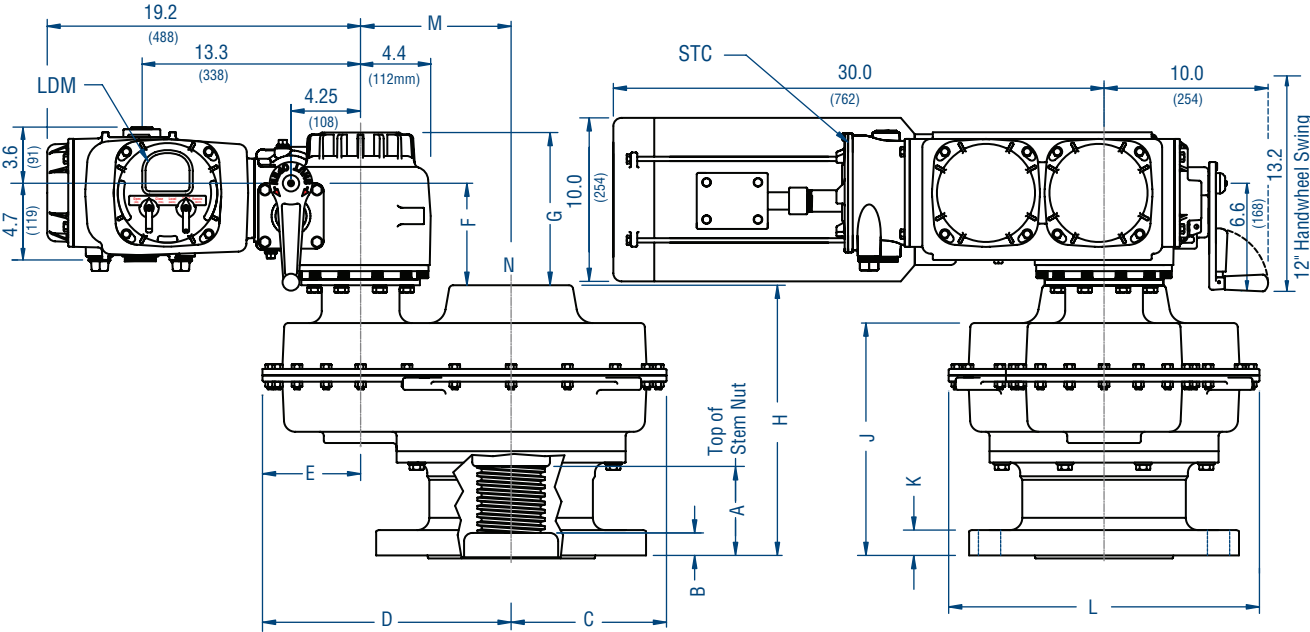

Bottom View of Conduit Entries

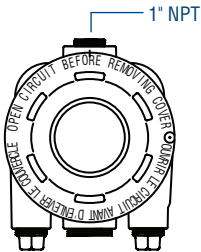

Side View of STC

Model Size	6000-1		6000-2/-3		7000	
	in.	mm	in.	mm	in.	mm
A Top of Bushing	4.20	107	5.40	137	9.00	229
B	0.60	15	1.40	35	2.90	74
C	9.50	241	9.50	241	17.90	455
D	15.20	386	15.20	386	23.60	599
E	6.00	153	6.00	153	6.80	173
F	6.30	160	6.30	160	-	-
G	9.40	239	9.40	239	7.90	201
H	14.80	376	16.50	419	-	-
J	12.50	318	14.30	363	16.50	419
K	0.85	21	1.56	40	2.03	52
L	19.00	483	19.00	483	36.00	914
M	9.20	234	9.20	234	16.80	427
N NPT	6"		6"		8"	

Mounting Base	6000-1	6000-2/-3	7000
MSS Std	FA30	FA36	FA40
ISO Std	F30	F35	F40

6000 & 7000 units are referenced with 215 frame motors.  
 8000 & 9000 units are custom; dimensions available upon request.

# OUTLINE DIMENSIONS

## SIDE-MOUNTED STYLE - M/MG02, M/MG03, M/MG05, W/MG05, W/MG07

FOR REFERENCE ONLY; use certified dimensions furnished with EIM job submittal.

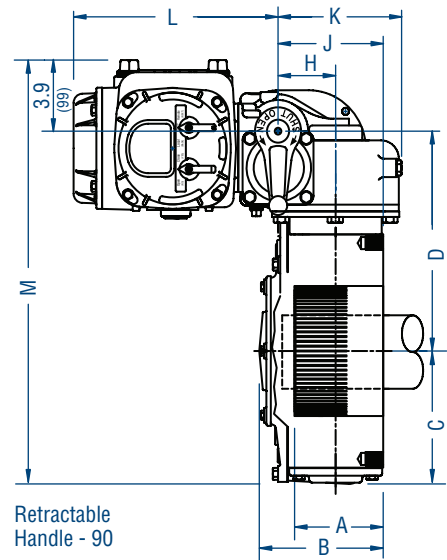
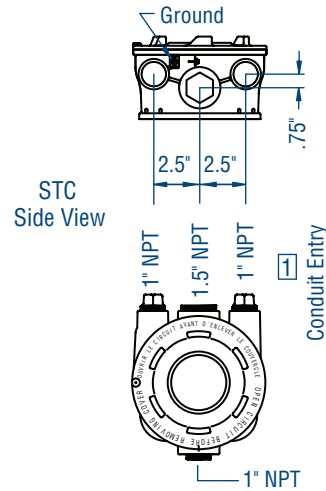
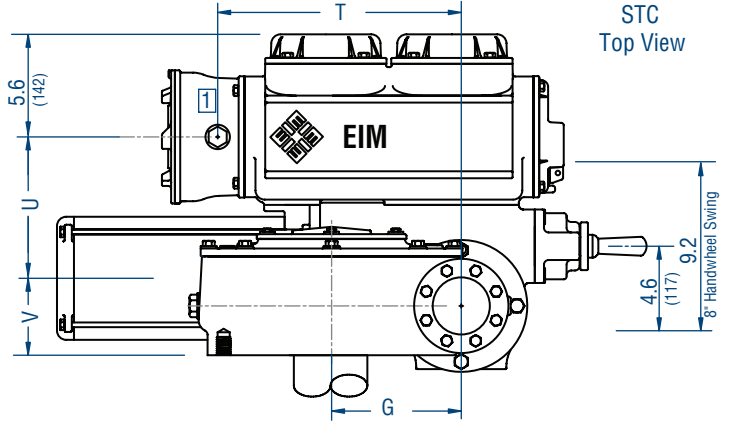
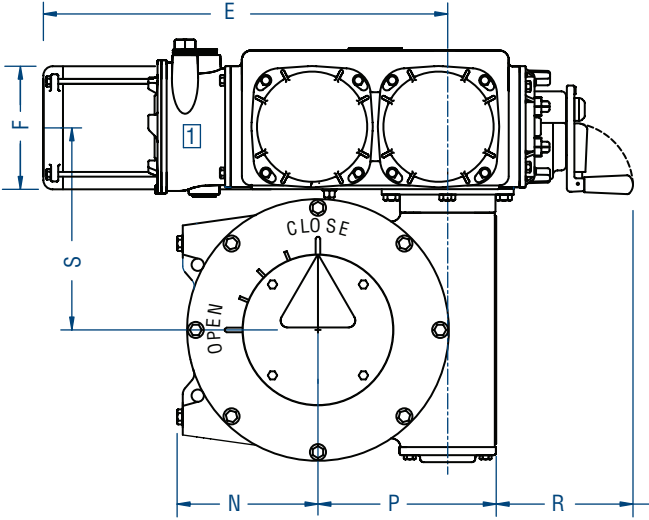

Model Size	Side-Mounted Style			Part-Turn Actuators	
	M/MG02	M/MG03	M/MG05	W/MG05	W/MG07/GB3
	in. mm	in. mm	in. mm	in. mm	in. mm
A Top of Bushing	3.6 91	5.0 127	7.0 178	7.0 178	9.0 229
B	6.5 165	7.0 178	8.5 216	8.5 216	11.0 279
C	5.7 145	7.2 183	10.6 269	10.6 269	14.0 356
D	10.5 267	11.9 300	16.5 419	18.0 457	26.2 665
E	22.0 559	22.0 559	22.0 559	30.0 762	35.0 889
F	6.7 170	6.7 170	6.7 170	10.0 254	10.0 254
G	4.25 108	7.1 180	10.45 265	10.45 265	14.0 356
H	3.25 83	3.25 83	3.25 83	4.25 108	4.25 108
J	5.9 151	6.0 152	6.9 175	7.9 200	9.8 249
K	7.0 178	7.0 178	6.9 175	8.6 218	8.6 218
L	11.5 292	11.5 292	11.5 292	14.9 378	14.9 378
M	20.1 551	23.0 584	31.0 787	32.5 826	44.2 1123
N	5.5 140	7.7 196	11.9 302	11.9 302	14.0 356
P	6.9 175	9.7 246	13.7 350	13.7 350	19.7 500
R	7.4 188	7.4 188	6.8 173	6.8 173	19.7 500
S	9.5 241	10.9 276	15.5 394	17.0 432	25.2 640
T	13.3 338	13.3 338	13.3 338	13.3 338	18.3 465
U	7.7 196	7.7 196	7.7 196	11.1 282	11.1 282
V	4.2 107	4.2 107	5.1 130	-	-

Mounting Base					
MSS Std	FA16	FA30	FA40	FA40	FA48
ISO Std	F16	F30	F40	F40	F48

- M/MG02, M/MG03 & M/MG05 units are referenced with 56 frame motors.
- W/MG05 & W/MG07 units are referenced with 215 frame motors.

# OUTLINE DIMENSIONS

## FLANGE ATTACHMENT

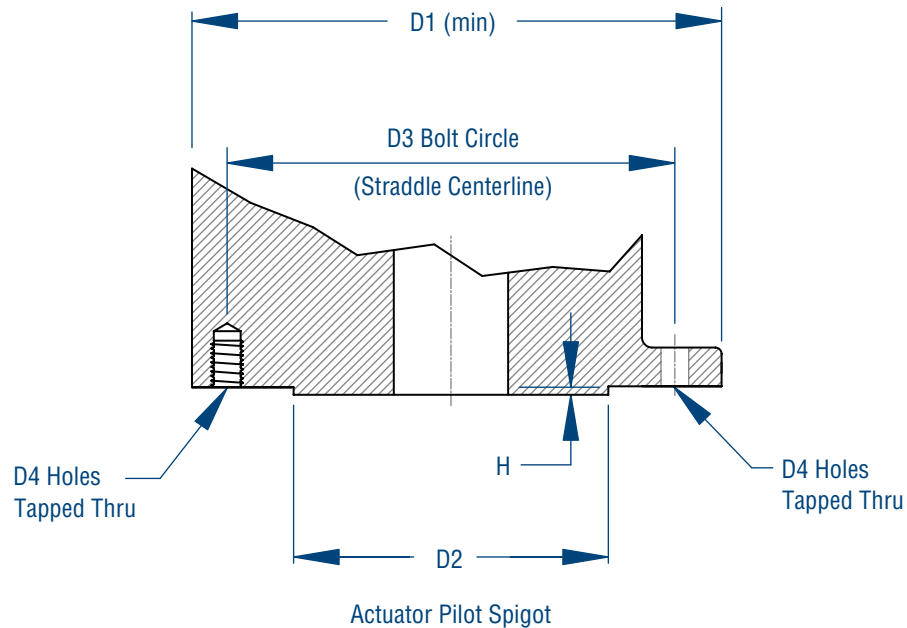

Mounting Base	D1 Flange O.D.	D2 Pilot Dia.	D3 Bolt Circle	No. Taps	D4 Tap Size	Thru Holes	H Pilot Depth
<b>MSS (inches)</b>							
FA10	4.92	2.312	4.00	4	3/8-16	-	0.12
FA12	5.91	-	4.95	4	1/2-13	-	0.12
FA14	7.25	3.750	5.50	4	5/8-11	-	0.16
FA16	8.63	5.000	6.50	4	3/4-10	-	0.19
FA25	11.38	6.000	10.00	8	-	21/32	0.19
FA30	13.63	7.000	11.75	8	-	25/32	0.19
FA36-Mod	18.70	8.500	14.00	8	-	1.36	0.19
FA40-Mod	18.70	9.000	16.00	8	-	1.36	0.32
<b>ISO (mm)</b>							
F10	125	70	102	4	M10	-	3
F12	150	85	125	4	M12	-	3
F14	175	100	140	4	M16	-	4
F16	210	130	165	4	M20	-	5
F25	300	200	254	8	M16	17	5
F30	350	230	298	8	M20	20	5
F35	415	260	356	8	M30	35	5
F40-Mod	475	300	406	8	M36	35	8
F48	560	370	483	12	M36	-	8

• Table for reference only; refer to EIM outline drawing for actual dimensions.

# CIRCUIT DIAGRAM CODING

Create a customized wiring diagram that meets your specifications by using the chart shown here.

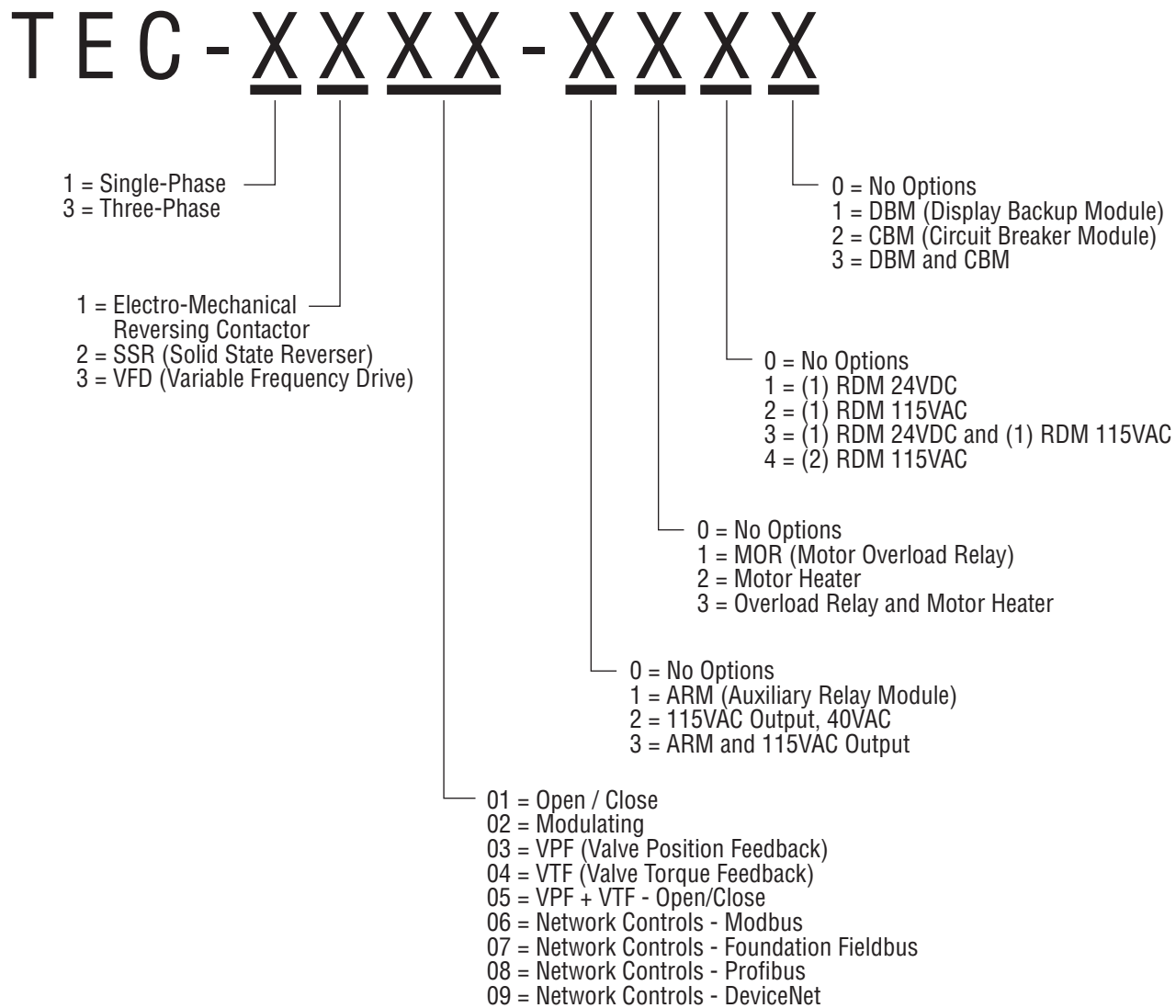

**Notes:**

1. Futronic II includes electro-mechanical reversing contactor.
2. Futronic IV includes solid state starter.
3. Futronic VIII includes VFD (Variable Frequency Drive).
4. All Futronics (Modulating) Controls include VPF (Value Position Feedback) and VTF (Value Torque Feedback) as standard. VPF & VTF are customer selectable.
5. ARM (Auxiliary Relay Module) is a available with Controlinc Network options.
6. For Open/Close function with SSR (Solid State Reverser), use Futronic IV.
7. TOR (Thermal Overload Relay) option, mounted internally in actuator, auto-reset.
8. CBM (Circuit Breaker Module) option, close-coupled to STC (Separate Terminal Chamber), or separate mounted.
9. VFD (Variable Frequency Drive) for Futronic VIII is mounted in a separate NEMA 4X enclosure.

# BASIC CIRCUIT DIAGRAM (Shown in CLOSE position, power off.)

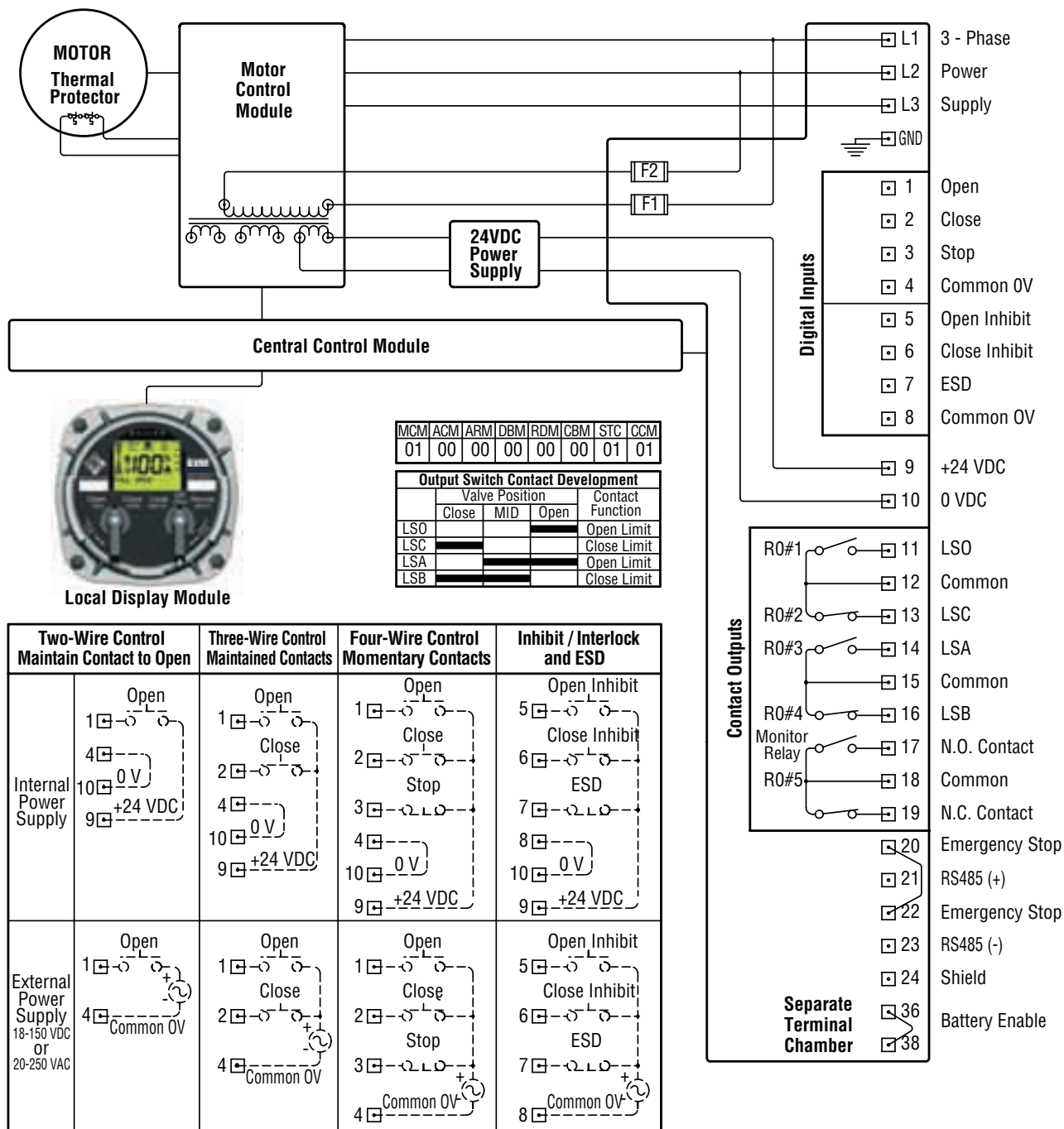

**NOTES:**

- 1) All digital inputs have an input voltage range of 18-150VDC or 20-250VAC.
- 2) All digital relay outputs are rated for 5A @ 30VDC or 5A @ 250VAC Resistive, 2A Inductive load.
- 3) Jumpers shown connected between terminals are permissible but not required.
- 4) Emergency stop requires jumper or normally closed contact (actuator stops when contact open).
- 5) Remote display communication port is RS-485.
- 6) If bare wires (without terminals) are connected, remove a maximum of .25 inch insulation.
- 7) User replaceable primary fuses (F1 and F2) are located in the terminal chamber enclosure. All transformer secondary fuses are automatic resetting.
- 8) Contact Outputs and Output Switch Contact Development Chart shown for default configuration only. User may redefine all Outputs (See TEC2000 Installation & Operation Manual E2K-405-0902).
- 9) Circuits are arranged for positive switching.
- 10) Internal power supply (24VDC) is isolated and regulated. Maximum capacity: 12W peak, 8W continuous.
- 11) Monitor relay indicates actuator available for remote control—shown de-energized (not available).

# REMOTE CONTROL CIRCUITS

## Two-wire Control with Maintained Contact to Open or Close

Two-wire control mode uses only one contact to control valve. Circuit shown is such that when contact is closed, valve opens, and when contact is open, valve closes. Seal-in is not active for two-wire control. Contact open and close configuration can be reversed in setup.

Internal Power Supply

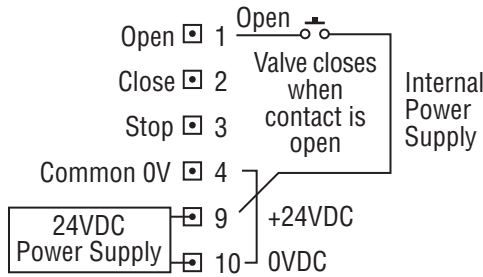

External Power Supply

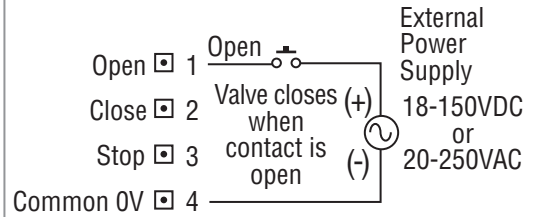

## Three-wire Control with Maintained (Push-to-Run) or Momentary Contact

(Maintained or Momentary mode is configured during setup)

Three-wire control mode uses two contacts to open or close valve. May be configured for Maintained (push-to-run) control or Momentary (seal-ins activated) control. When seal-ins activated, valve control cannot be stopped in mid-travel (unless inhibit, ESD, or emergency STOP signal is active.)

Internal Power Supply

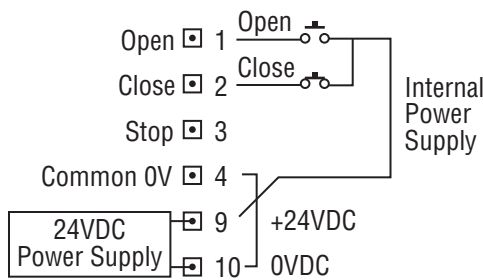

External Power Supply

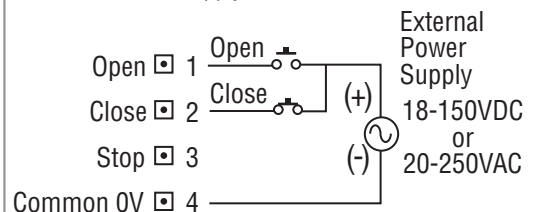

## Four-wire Control with Momentary Contact and Mid-Travel Reversal

Four-wire control mode uses three Momentary (seal-ins activated) contacts to open, close, or stop valve in mid-travel. Default configuration for stop input is "active on open contact" but this can be changed in setup.

Internal Power Supply

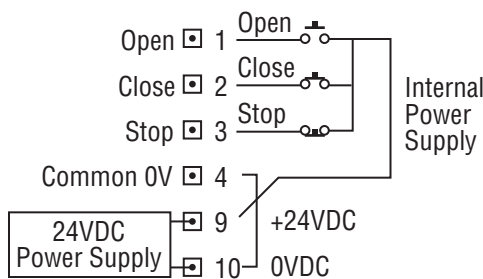

External Power Supply

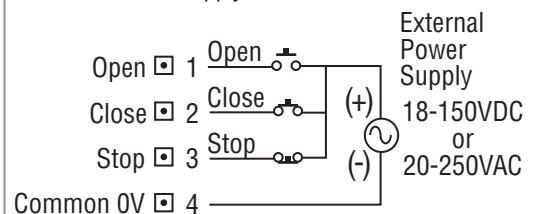

# EMERGENCY SHUTDOWN ESD & INHIBIT/INTERLOCK CONTROL CIRCUITS

## Emergency Shutdown ESD

*Internal Power Supply*

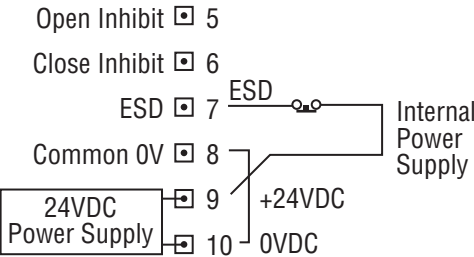

*External Power Supply*

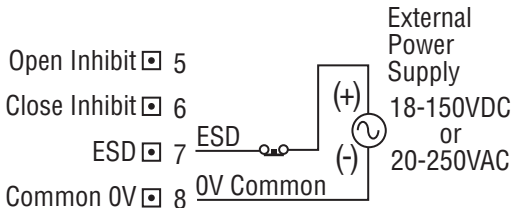

## Inhibit/Interlock

*Internal Power Supply*

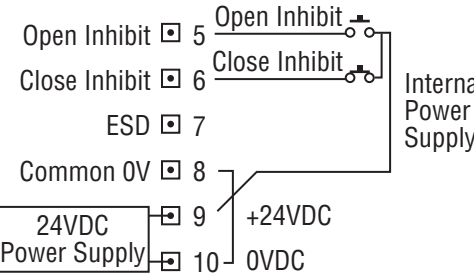

*External Power Supply*

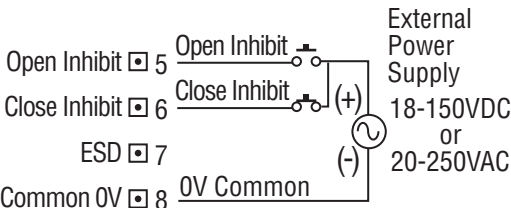

## Local Emergency STOP - Hardwired

Local Emergency STOP contact bypasses all electronics and overrides all local and remote signals to ensure actuator stops and "stays-put" in that position.

Local Emergency STOP requires jumper or normally closed contact (actuator stops when contact opens).



## OPTIONAL INDICATION & CONTROL CIRCUITS

### Auxiliary Relay Module (ARM)

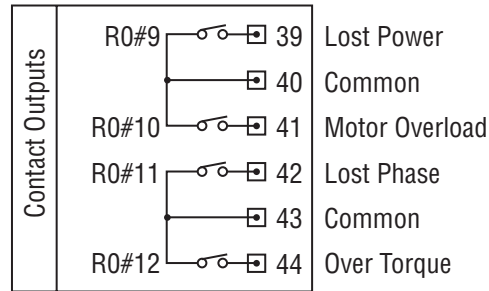

All auxiliary relay output contacts (R0#9 – 12) are latching-type rated for 5A @ 30V dc or 5A @ 250V ac Resistive, 2A Inductive load.

Shown in default configuration and "not true" state (contacts are set to "flash" by default). Alternative alarm and status settings can be configured during setup. Normally open, normally close, and flashing mode are selectable.

### Valve Position Feedback (AO#1) - VPF

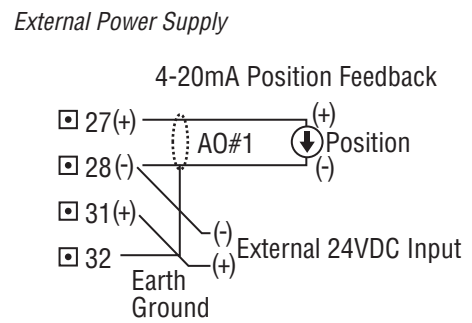
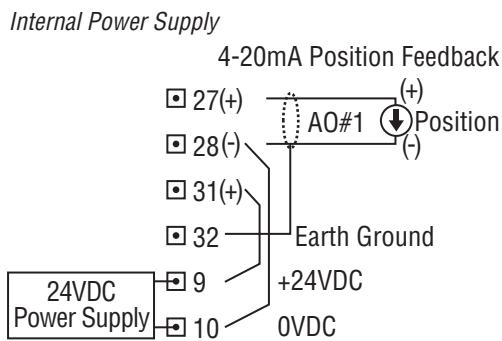

### Valve Torque Feedback (AO#2) - VTF

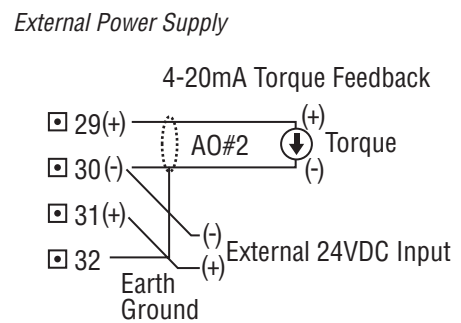
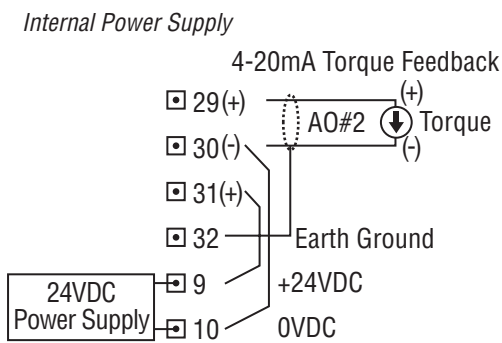

### Analog Position Control (AIN#1) - Futronic

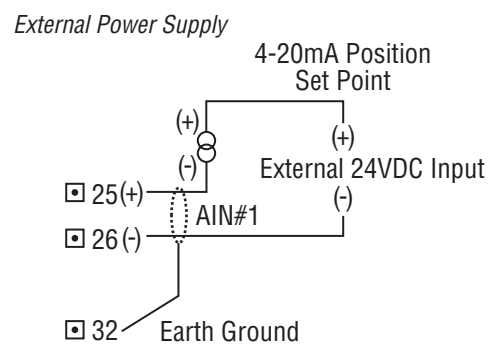
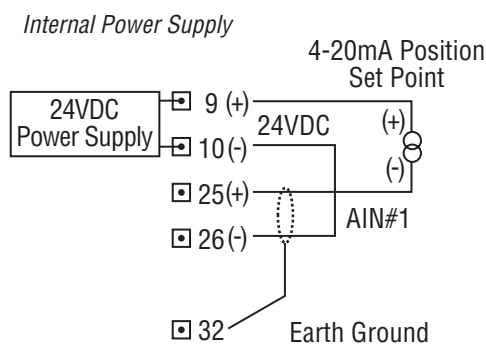

**OPTIONAL INDICATION AND CONTROL MODULES**

**Three-Wire Analog Position Control Option**

When 3-wire toggle switch is made at terminal 3, then actuator is controlled by the discrete Open and Close commands at terminals 1 and 2. When 3-wire toggle switch is open, then actuator is controlled by 4-20mA analog input.

*Internal Power Supply*

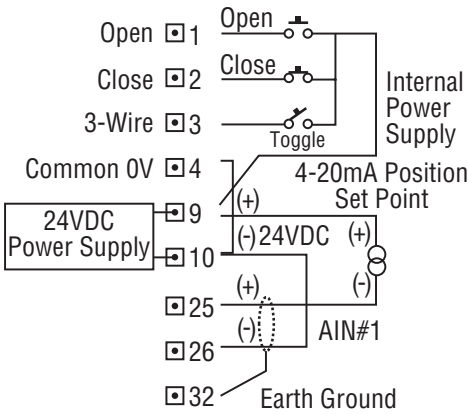

*External Power Supply*

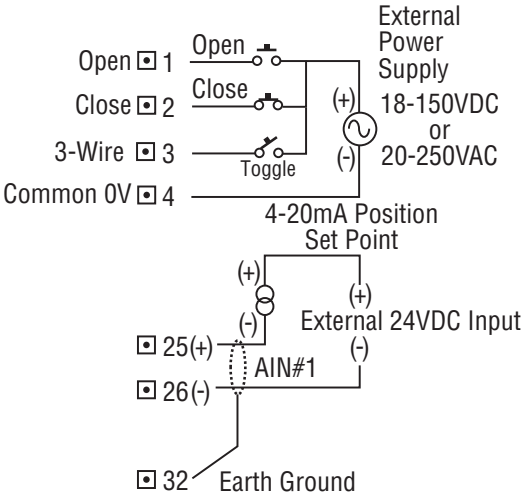

**External Variable Frequency Drive (VFD) Control - Futronic VIII**

VFD applications require configuration at EIM factory and employ a different STC terminal arrangement. The VFD Controller is mounted in a separate enclosure close-coupled to actuator or installed adjacent to it. Maximum distance between VFD Controller and actuator is 150 m (500 ft.).

*Internal Power Supply*

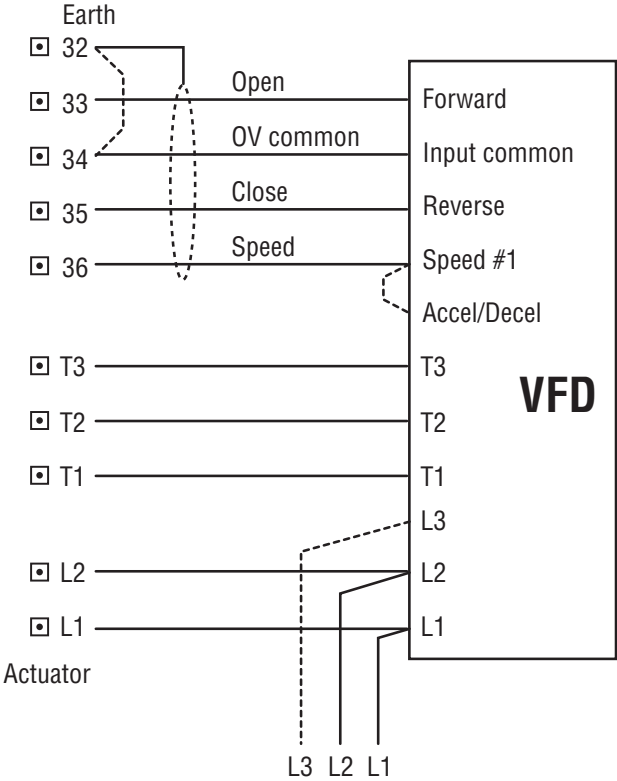

Connect L3 for 3-Phase power;  
Use L1 and L2 for 1-Phase power

## OPTIONAL INDICATION AND CONTROL MODULES

### Local/Remote Control from Remote Display Module (RDM)

#### One RDM with 24VDC Power Source from Actuator

Maximum Distance from Actuator:

- 1200 meters (4000 ft)
  - Belden 8719 (or equivalent) for 24VDC power
  - Belden 9841 (or equivalent) for RS-485 communications
- 366 meters (1200 ft)
  - Belden 8723 (or equivalent) for 24VDC power and RS-485 communications

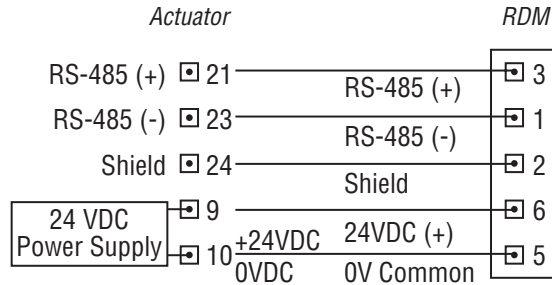

Remote Display Module (24VDC)

#### One RDM with 115/230VAC External Power Source

Maximum Distance from Actuator:

- 1200 meters (4000 ft)
  - Local supply for power, 115/230VAC
  - Belden 9841 (or equivalent) for RS-485 communications

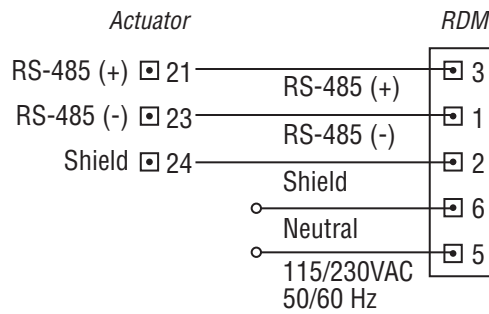

Remote Display Module (115/230VAC)

#### Two RDMs (one 24VDC and one 115/230VAC Power Source)

Refer to cable recommendations above for optimal performance.

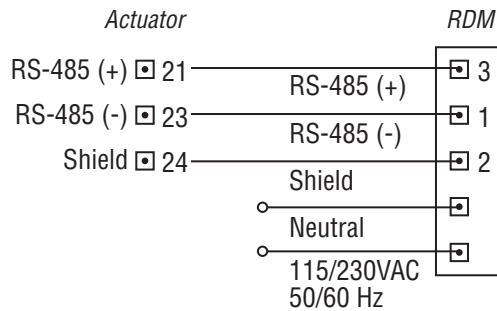

Remote Display Module #1 (115/230VAC)

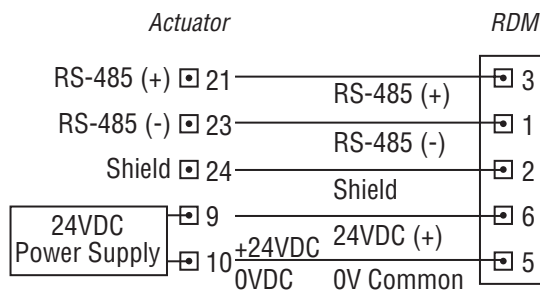

Remote Display Module #2 (24VDC)

# CONTROLINC® DIGITAL NETWORK CONTROLS

Controlinc® -  
Modbus RTU

Redundant Serial E>Net Ring Topology

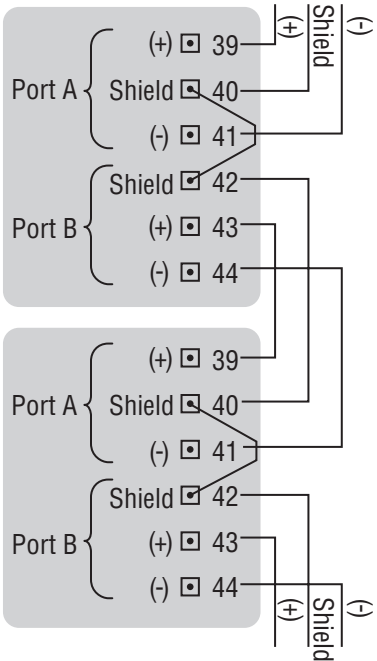

Multi-Drop Topology

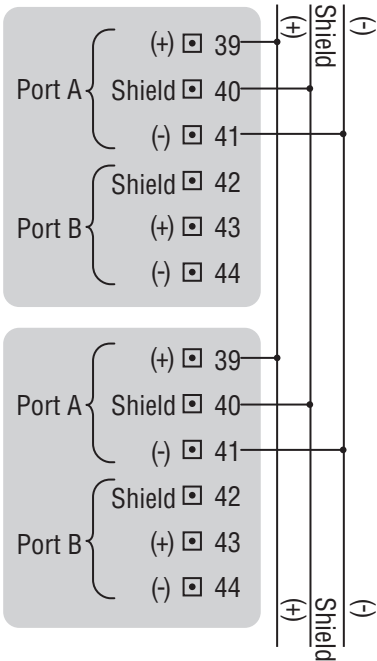

Controlinc® -  
Foundation Fieldbus

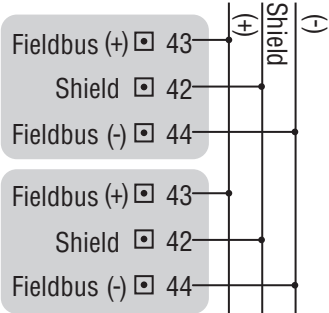

Controlinc® -  
Profibus

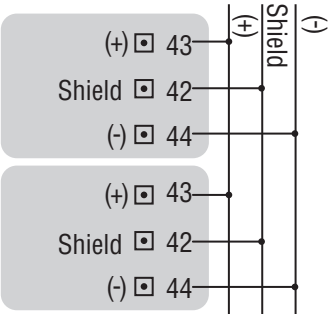

## TEC2000 OPTIONS AND ACCESSORIES



*Figure 19: STC (Separate Terminal Chamber) and LDM (Local Display Module) alternate mounting locations*



*Figure 20: Close Coupled CBM (Circuit Breaker Module)*



*Figure 21: 6000 & 7000 Series Actuators*



## Contact us at your nearest location:

### North & South America

13840 Pike Road  
Missouri City, Texas 77489 USA  
T +1 281 499 1561  
F +1 281 499 8445

18703 GH Circle  
PO Box 508  
Waller, TX 77484 USA  
T +1 281 727 5300  
F +1 281 727 5353

9009 King Palm Drive  
Tampa, FL 33619 USA  
T +1 813 630 2255  
F +1 813 630 9449

Av. Hollingsworth,  
325, Iporanga Sorocaba,  
SP 18087-105 Brazil  
T +55 15 3238 3788  
F +55 15 3228 3300

### Middle East & Africa

P. O. Box 17033  
Dubai, United Arab Emirates  
T +971 4 811 8100  
F +971 4 886 5465

P. O. Box 105958  
Abu Dhabi, United Arab Emirates  
T +971 2 697 2000  
F +971 2 555 0364

P. O. Box 3911  
Al Khobar 31952 Saudi Arabia  
T +966 3 814 7560  
F +966 3 814 7570

P.O. Box 10305  
Jubail 31961 Saudi Arabia  
T +966 3 340 8650  
F +966 3 340 8790

### Emerson Process Management Valve Automation

13840 Pike Rd.  
Missouri City, Texas 77489 USA  
T +1 800 679 1561 - toll-free USA  
T +1 281 499 1561  
F +1 281 499 8445  
info.MissouriCity@Emerson.com

P. O. Box 32281  
Doha, Qatar  
T +974 4 576777  
F +974 4 315448

2 Monteer Road, Isando  
Kempton Park, 1600  
South Africa  
T +27 11 974 3336  
F +27 11 974 7005

### Europe

Asveldweg 11  
7556 BR Hengelo (O)  
The Netherlands  
T +31 74 256 1010  
F +31 74 291 0938

Siemensring 112  
47877 Willich, Germany  
T +49 2154 499 660  
F +49 2154 499 6613

30/36 Allee du Plateau  
93250 Villemomble, France  
T +33 1 48 12 26 10  
F +33 1 48 12 26 18

Via Bardelli, 3  
20131 Milano, Italy  
T +39 02 26683164  
F +39 02 26683164

6-7 Galaxy House  
New Greenham Park  
Newbury, Berkshire  
England RG19 6HW  
T +44 (0) 1635817315  
F +44 (0) 1635817460

### Emerson Process Management Valve Automation

6-7 Galaxy House  
New Greenham Park  
Newbury, Berkshire  
England RG19 6HW  
T +44 0 1635 817 315  
F +44 0 1635 817 460  
info.England@Emerson.com

6 Bracken Hill  
South West Industrial Estate  
Peterlee SR8 2LS, United Kingdom  
T +44 191 518 0020  
F +44 191 518 0032

ul. Konstruktorska str 11A  
02-673 Warsaw, Poland  
T +48 22 4589237  
F +48 22 45 89 231

C/ Francisco Gervás, 1  
28108 Alcobendas  
Madrid, Spain  
T +34 0913 586 000  
F +34 0913 589 145

Letnikovskaya Str. 10-2  
115114 Moscow  
Russia and FSU  
T +7 495 981 98 11  
F +7 495 981 98 10

### Asia Pacific

19 Kian Teck Crescent  
Singapore 628885  
T +65 6501 4600  
F +65 6268 0028

9/F Gateway Building  
No. 10 Ya Bao Road  
Chaoyang District  
Beijing 100020, P.R.China  
T +86 10 5821 1188  
F +86 10 5821 1100

Room 618, Prime Tower  
No. 22, Chaowai Avenue,  
Chao Yang District,  
Beijing, China 100020  
T +86 10 6588 9928  
F +86 10 6588 9929

471 Mountain Highway  
Bayswater, Victoria 3153  
Australia  
F +61 3 9720 0588

301 Solitaire Corporate Park  
151 M.V.Road, Andheri (E)  
Mumbai . 400093  
Maharashtra, India  
T +91 22 6694 2711  
F +91 22 2825 3394

NOF, Shinagawa Konan Bldg  
1-2-5, Higashi-shinagawa  
Shinagawa-ku, Tokyo  
140-0002 Japan  
T +81 3 5769 6873  
F +81 3 5769 6902



Class I, II, III Div. 1  
Groups B, C, D, E, F, G  
T4 & T4A @ Ta 60°C, Type 6P



Class I, II, III Div. 1  
Groups B, C, D, E, F, G  
T4 & T4A @ Ta 60°C, Type 6P



EEx d IIB T4 & 120° (T4)  
@ Ta 60°C, IP68  
EEx d IIB + H2 T4 @ 120° (T4)  
@ Ta 60°C, IP68



Ex d IIB T4 & 120° (T4)  
@ Ta 60°C, IP68  
Ex d IIB + H2 T4 & 120° (T4)  
@ Ta 60°C, IP68

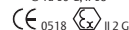

© 2010 Emerson Process Management. All rights reserved.

The Emerson logo is a trademark and service mark of Emerson Electric Co. "Brand mark listing" are marks of one of the Emerson Process Management family of companies. All other marks are property of their respective owners.

The contents of this publication are presented for information purposes only, and while every effort has been made to ensure their accuracy, they are not to be construed as warranties or guarantees, express or implied, regarding the products or services described herein or their use or applicability. All sales are governed by our terms and conditions, which are available on request. We reserve the right to modify or improve the designs or specifications of our products at any time without notice.



E2K-205-0710

www.eim-co.com

