



Actuators & Controls

A

SERVICE MANUAL No. I-0220

PRESSUREMATIC

CUSTOMER: _____

P.O.#: _____

W.O.#: _____

TAG: _____

DATE: _____

APPLIES TO PRESSUREMATIC OPERATOR MODEL: _____

	<u>DESCRIPTION</u>	<u>DWG.NO</u>	<u>PAGE</u>
	OPERATION AND ADJUSTMENTS	C-0098	2
	PRESSUREMATIC ASSEMBLY	APB0570	3
	PRESSUREMATIC ASSEMBLY WITH MANUAL RESET	CB0066-10	4
	PRESSUREMATIC SUBASSEMBLY DETAILS	APB0584	5
I	MODEL AND SPRING SELECTION		6
II	ADJUSTMENT PROCEDURE		6
III	PRESSUREMATIC SET POINT ADJUSTMENT		8
IV	RANGE SCREW ADJUSTMENT		9
	TRIP SPRING RETAINER DIAGRAM	I-0221	10
V	RANGE VERIFICATION PROCEDURE		11
VI	REASSEMBLY		11
VII	MODIFYING PRESSUREMATIC ASSEMBLY TYPE		12
	RANGE TABLE	APB0579 (1 OF 2)	13
	RANGE GRAPH	APB0579 (2 OF 2)	14
VIII	NOTES... ..		15

I-0220--.WPD/1
REV3:FEB-18-97

OPERATION AND ADJUSTMENTS

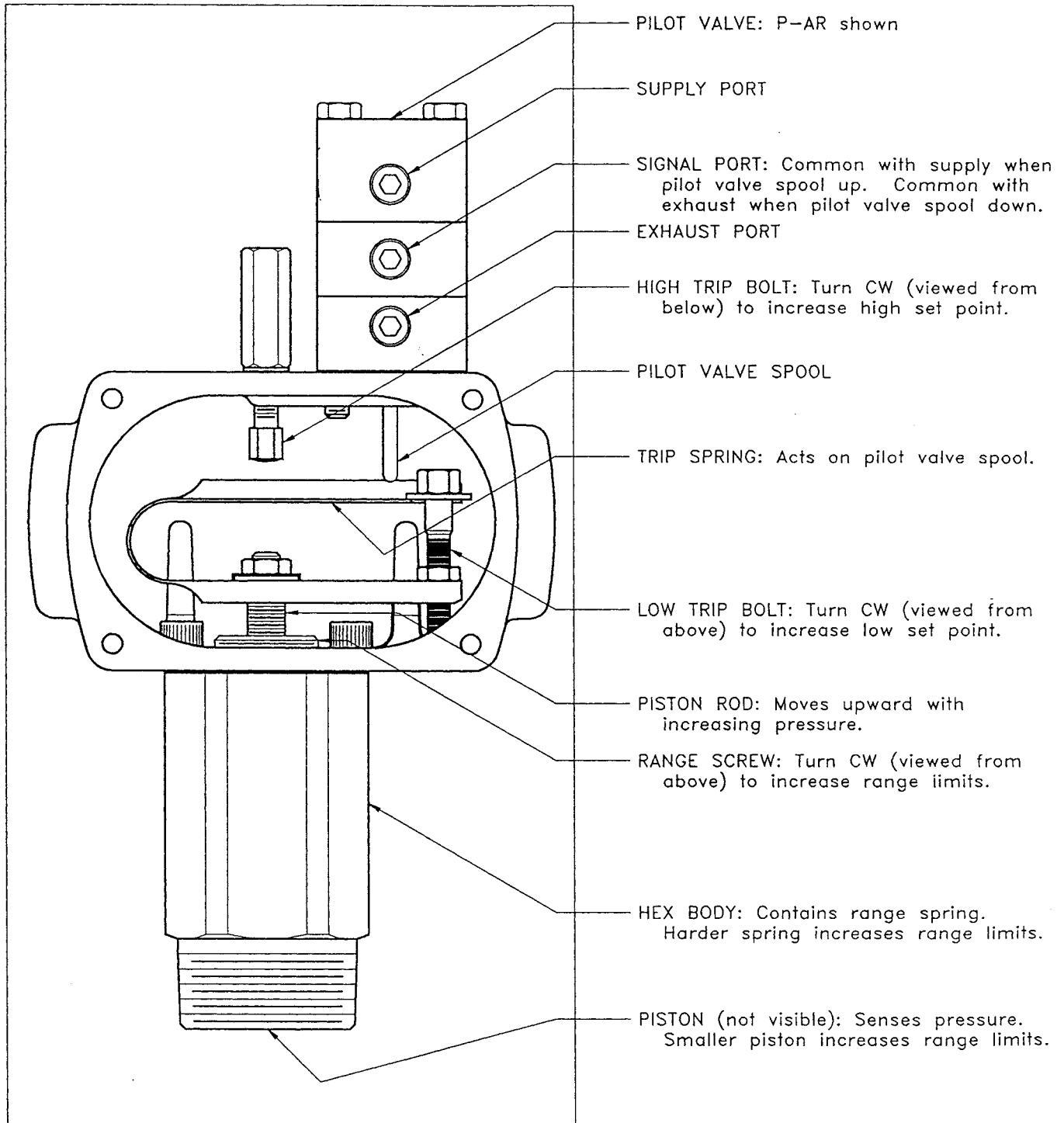

C-0098--.DWG ORIG MAR-10-92
SCALE 1:2 REV 1- AUG-16-96

ITEM	DESCRIPTION	MATERIAL	QTY	NOTE
1	BODY	CI018	1	
2	RETAINING RING, BODY	SS 304	1	
3	PISTON	SS 316	1	
4	SEAL #1, PISTON	TFE	1	(Y)
5	SEAL #2, PISTON	NITRILE	1	(Y)
6	HIGH TRIP BLIND NUT	AL 2011-T3	1	
7	SPRING SEAT	CS PL	1	(V)
8	RANGE SPRING	CR-V ALLOY	1	
9	BOLT, BODY	SS 304	2	
10	GASKET, BODY	PLANT FIBRE	1	(Y)
11	RANGE SCREW	SS 416	1	
12	JAM NUT, TRIP SPRING	SS 304	1	
13	JAM NUT, LOW-TRIP BOLT	SS 304	1	
14	TRIP SPRING ASSEMBLY	SS 301	1	
15	LOW TRIP ADJUSTMENT BOLT	AL 6061-T6	1	
16	HIGH TRIP BOLT	SS 316	1	
17	HOUSING	AL CAST	1	
18	COVER PLATE	AL CAST	1	(Y)
19	O-RING, COVER	NITRILE	1	
20	BOLT, COVER	SS 304	4	
21	NAMEPLATE	SS 304	1	
22	DRIVE SCREW, NAMEPLATE	SS 18-8	4	
23	WASHER, TRIP SPRING	SS 304	3	
24	STAT-O-SEAL	CS/NITRILE	1	(Y)
25	LOWER BODY, PILOT	AL 6061-T6	1	
26	UPPER BODY, PILOT	AL 6061-T6	1	
27	END CAP, PILOT	AL 6061-T6	1	(Y)
28	FILTER ELEMENT, PILOT	CELLULOSE/RESIN	2	
29	CAPSCREW, END CAP	SS 304	1	
30	SPRING, POPPET	SS 302	1	(Y)
31	POPPET, PILOT	TFE	1	(Y)
32	O-RING, UPPER BODY	NITRILE	1	(Y)
33	SPOOL, PILOT	SS 304	1	(Y)
34	RETAINING RING, SEAL	SS 304	1	(Y)
35	O-RING, SPOOL	NITRILE	2	(Y)
36	SPRING, SPOOL	SS 302	1	
37	RETAINING RING, SPOOL	SS 304	2	
38	GASKET, PILOT	PLANT FIBRE	1	(Y)
39	CAPSCREW, PILOT MOUNTING	SS 304	2	
40	SLEEVE, PILOT	DELFIN	1	(Y)
41	O-RING, SLEEVE	NITRILE	1	(Y)
42	BUSHING, SPOOL	TFE	1	

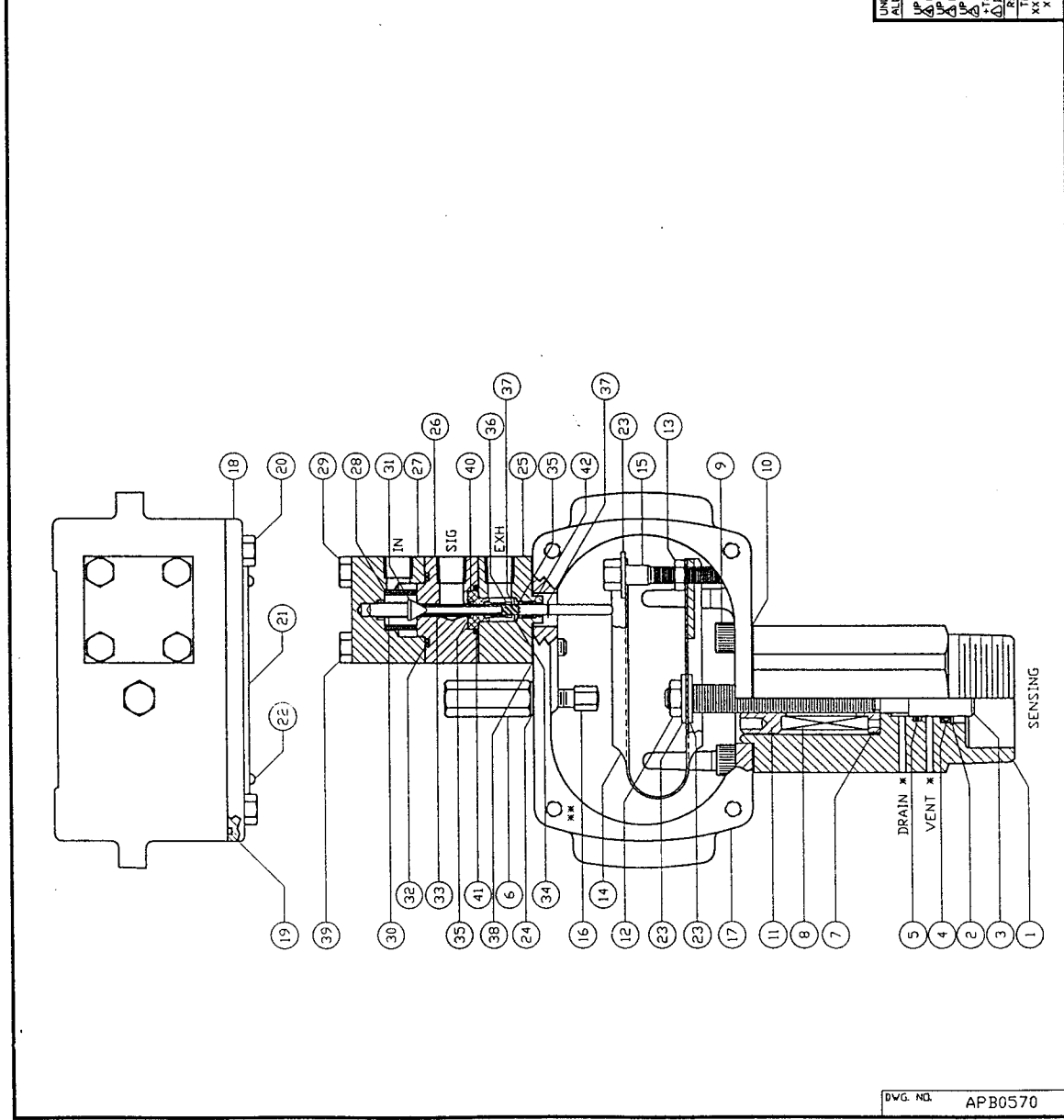

NOTE: (Y) RECOMMENDED SPARE PARTS/REPAIR KIT, (V) TO BE SPECIFIED
 FASTENERS AND MAINTENANCE TOOLS ARE ANSI/INCH SIZE
 * VENT AND DRAIN SHOWN -30° FROM TRUE POSITION
 ** SHOWN WITH COVER REMOVED

BETTS BETTS CANADA LTD.
 Accounts Control
 PRESSUREMATIC ASSEMBLY
 (P-AR2000 TYPICAL, CS BODY, STD TRIM)

UNLESS SPECIFIED OTHERWISE
 ALL DIMENSIONS INCHES (mm)

UPDT HOUSING '17', BOLTS WERE CS
 AS-1996-08-14 @ SALES RED
 AS-1995-12-13 @ SALES RED
 UPDT SPOOL, TFE POPPET
 BY-1993-03-24 @ 9248
 TRIP SPRING AND WASHER
 REV BY-DATE-REF
 8/9280

WEIGHT 11.0 LB
 SCALE 1:2 BY DY ICHK
 DATE 11/29/12/12
 V.D. 8980-R&D P.V.G. NO. APB0570
 REV 4-

P.V.G. NO. APB0570

ITEM	DESCRIPTION	MATERIAL	QTY	NOTE	ITEM	DESCRIPTION	MATERIAL	QTY	NOTE
43	MANIFOLD, RESET VALVE	AL 6061-T6	1	(1)	1	BODY	ASTM A108 GR C1018	1	
44	CAPSCREW, MANIFOLD	SS 304	2		2	RETAINING RING, BODY	SS 304	1	
45	O-RING, MANIFOLD	NITRILE	2	(Y)	3	PISTON	SS 316	1	
46	PLUG, MANIFOLD	SS 304	1		4	SEAL #1, PISTON	TFE	1	(Y)
47	O-RING, MANIFOLD	NITRILE	4	(Y)	5	SEAL #2, PISTON	NITRILE	1	(Y)
101	BODY, RESET VALVE	AL 6061-T6	1		6	HIGH TRIP BLIND NUT	AL 2011-T3	1	
103	CAPSCREW, RESET VALVE	SS 304	3		7	SPRING SEAT	AISI A128L14 ZN PL	1	(V)
104	SLEEVE RETAINER	AL 6061-T6	1		8	RANGE SPRING	CR-V ALLDY	1	(V)
105	CAPSCREW, SLEEVE RET	SS 304	2		9	BOLT, BODY	SS 304	2	
106	TOGGLE ASSEMBLY	AL 6061-T6/SS 301	1		10	GASKET, BODY	PLANT FIBRE	1	(Y)
107	SLOTTED SPRING PIN	SS 420	1		11	RANGE SCREW	SS 416	1	
108	WASHER, TOGGLE	NYLON	1	(Y)	12	JAM NUT, TRIP SPRING	SS 304	1	
109	SPPOOL, RESET VALVE	AL 6061-T6	1		13	JAM NUT, LOW TRIP BOLT	SS 304	1	
110	WASHER, SPRING	AL 6061-T6	1		14	TRIP SPRING ASSY	SS 301	1	
111	O-RING, SLEEVE STEM	SS 302	1	(Y)	15	LOW TRIP ADJ BOLT	AL 6061-T6	1	
112	O-RING, SLEEVE STEM	NITRILE	1	(Y)	16	HIGH TRIP BOLT	SS 316	1	
113	O-RING, SPOOL	NITRILE	1	(Y)	17	HOUSING	TENZALLOY	1	
114	O-RING, SPOOL PISTON	NITRILE	1	(Y)	18	COVER PLATE	AL CAST	1	
115	SLEEVE, RESET VALVE	TEFLON	1	(Y)	19	O-RING, COVER	NITRILE	1	(Y)
116	O-RING, SLEEVE HEAD	NITRILE	1	(Y)	20	BOLT, COVER	SS 304	4	
117	O-RING, SLEEVE	NITRILE	1	(Y)	21	NAMEPLATE, COVER	SS 304	1	
118	O-RING, RESET VALVE	NITRILE	1	(Y)	22	DRIVE SCREW, NAMEPLATE	SS 304	4	
119	PLUG, MANIFOLD	SS 304	2		23	FLATWASHER	SS 304	3	
120					24	STAT-O-SEAL	CS RET/NITRILE SEAL	1	(Y)
121					25	LOWER BODY, PILOT	AL 6061-T6	1	
122					26	UPPER BODY, PILOT	AL 6061-T6	1	
123					27	END CAP, PILOT	AL 6061-T6	1	
124					28	FILTER ELEMENT, PILOT	CELLULOSE/RESIN	1	(Y)
125					29	CAPSCREW, END CAP	SS 304	2	
126					30	SPRING, POPPET	SS 302	1	
127					31	POCKET, PILOT	TFE	1	(Y)
128					32	O-RING, UPPER BODY	NITRILE	1	(Y)
129					33	SPOOL, PILOT	SS 304	1	
130					34	RETAINING RING, SEAL	SS 304	1	(Y)
131					35	O-RING, SPOOL	NITRILE	2	(Y)
132					36	SPRING, SPOOL	SS 302	1	
133					37	RETAINING RING, SPOOL	SS 304	2	
134					38	GASKET, PILOT	PLANT FIBRE	1	(Y)
135					39	CAPSCREW, PILOT MOUNTING	SS 304	2	
136					40	SLEEVE, PILOT	DELFIN	1	(Y)
137					41	O-RING, UPPER BODY	NITRILE	1	(Y)
138					42	BUSHING, SPOOL	TFE	1	

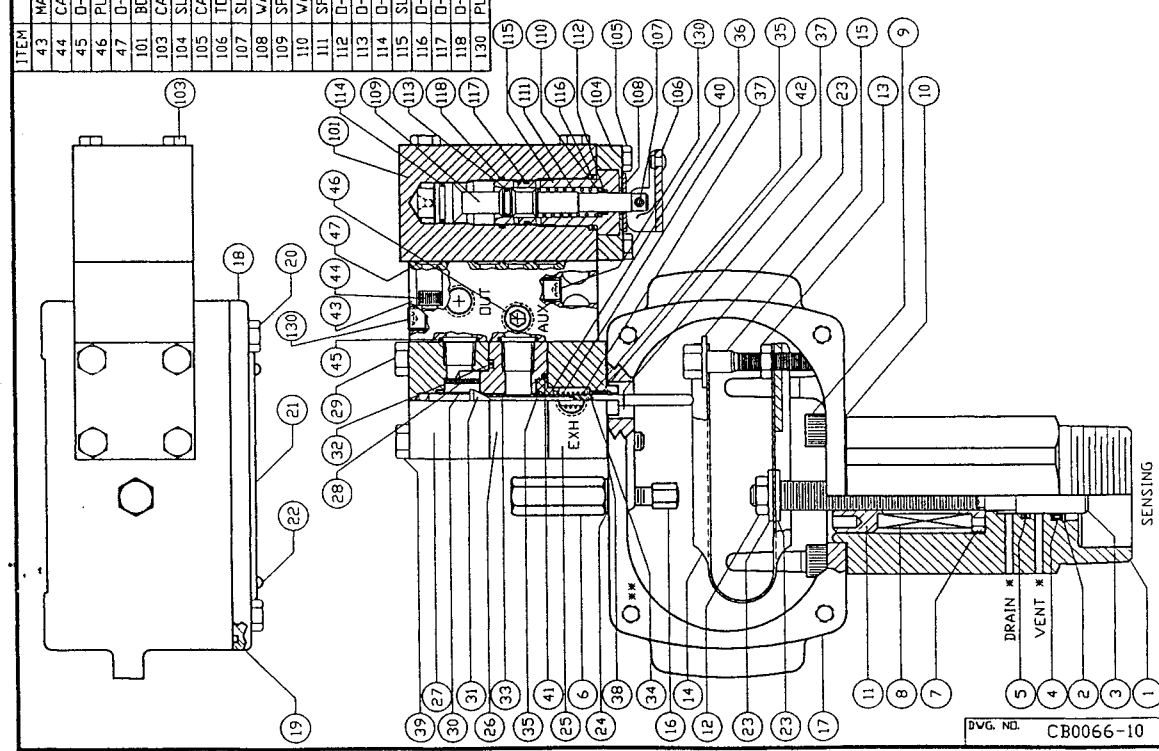

NOTE: (1) MANIFOLD MUST BE ASSEMBLED WITH PLUGS, ITEM '130'
 (Y) RECOMMENDED SPARE PARTS/REPAIR KIT. (V) TO BE SPECIFIED
 FASTENERS AND MAINTENANCE TOOLS ARE ANS/INCH SIZE
 * VENT AND DRAIN SHOWN -30" FROM TRUE POSITION
 ** SHOWN WITH COVER REMOVED

BETTS
 BETTS CANADA LTD.
 Actuators & Controls
 PRESSUREMATIC ASSEMBLY
 (P-MR2000 TYPICAL) WITH O-RINGS

UNLESS SPECIFIED OTHERWISE
 ALL DIMENSIONS IN INCHES (mm)

UPDT HOUSING, REVISE ITEM LIST
 AS-1996-11-30 66051-B
 REV BY-DATE-REF
 XX 202 1450
 XX 202 1450
 X 401 6421

DWG. NO. CB0066-10

SCALE 1:2 BY RS [Signature] DATE JUN-19-96
 V.O. 09233-3-R DWG. NO. CB0066-10 REV 1-

I MODEL AND SPRING SELECTION

1. Scope

This procedure describes the model and spring selection of Pressurematic Series 2000, 2200 and 2400. Set point adjustment (Section II) may be done in the field.

2. Reference Drawings

- a) APB0570 Pressurematic Assembly (P-AR 2000)
- b) APB0579, page 1 of 2, Range Table for Pressurematic P-AR/MR 2200/2000/2400
- c) APB0579, page 2 of 2, Range Graph for Pressurematic P-AR/MR 2200/2000/2400

3. Schematic diagram of adjustments

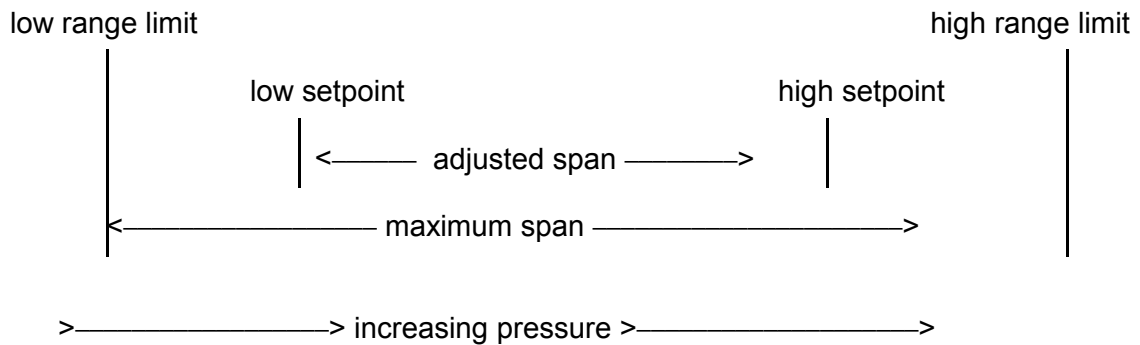

Based on data tabulated in the Range Table APB0579, select a Pressurematic series and spring combination to meet the requirements for range limits, span, and/or deadband. Use the largest piston and softest spring which will satisfy these requirements. This will minimize deadband.

II ADJUSTMENT PROCEDURE

1. Set Point Adjustment

Field/bench Setpoint Verification

Calibration Equipment:

- 1. N₂ bottle
- 2. HP regulator
- 3. LP regulator
- 4. hose
- 5. block and bleed valve
- 6. test gauge, 0-1500 psi range
(recommended or range as required)
- 7. test gauge, 0-150 psi range

Insert C-0099-10
Cut to 3.5 inches²

2. Range Screw Adjustment

The objective is to set the range screw such that the adjusted span will be approximately centered between the range limits. In the case of high or low set point only, the set point is to be approximately centered between the range limits.

This is done with housing and trip spring removed and with a dial indicator to indicate piston position. Adjust the range screw to give 0.020 inch piston travel at the low range limit pressure. The low range limit may be specified by the customer, but if not, it can be determined as follows:

a) For cases with low and high set points:

$$\text{Low Range Limit} = (\text{low set point}) - \left(\frac{ (\text{maximum span}) - (\text{high set point}) + (\text{low set point}) }{ 2 } \right)$$

where "maximum span" is from Range Table APB0579 for zero range screw turns. If the calculated low range limit is below that shown in the Range Table for zero range screw turns, then use the Range table value.

b) For cases with low set point only:

$$(\text{Low Range Limit}) = (\text{set point}) - \left(\frac{ \text{maximum span} }{ 2 } \right)$$

where "maximum span" is from Range Table for maximum range screw turns. If the calculated low range limit is below that shown in the Range Table for zero range screw turns then use the Range table value.

c) For cases with high set point only:

$$(\text{Low Range Limit}) = (\text{set point}) - \left(\frac{ \text{maximum span} }{ 2 } \right) - 100$$

where "maximum span" is from Range Table for maximum range screw turns. If the calculated low range limit is below that shown in the Range Table for zero range screw turns then use the Range table value.

III PRESSUREMATIC SET POINT ADJUSTMENT

Set point adjustment for Series 2000, 2200, 2400:

NOTE: Refer to Pressurematic assembly drawing APB0570.

This is done with the assembly complete and supply air on the pilot valve for P-AR and P-MR models.

NOTE: In the field this requires a calibration kit with the ability to supply high and low setpoint pressures (eg. nitrogen bottle with block & bleed valve).

1. Cases with low and high set points:

NOTE: The low set point must be adjusted first. It will not be affected by the high set point adjustment but the high set point is affected when the low set point is adjusted.

- a) Set the high trip bolt fully away from the trip spring.
- b) Repeatedly adjust the low trip bolt and decrease pressure through the low set point until the low trip occurs consistently at the low set point. Tighten the lock nut and recheck. Check that there is at least 0.02 inch piston travel from low trip to bottom stop.

NOTE: When adjusting the low trip bolt, the upper arm of the trip spring must be pushed down. This unloads the bolt and allows it to be turned by hand.

- c) Repeatedly adjust the high trip bolt and increase pressure through the high set point until the high trip occurs consistently at the high set point. Tighten the lock nut and recheck.

2. Cases with low set point only:

- a) Set high trip bolt fully away from the trip spring.
- b) Adjust the low set point as described in 1.b) above.
- c) To disable high trip, increase pressure until piston is at upper stop. Adjust high trip bolt downward until high trip occurs then retract 1/2 turn. Check that high trip does not occur when piston travels to upper stop. This high trip bolt adjustment is to prevent the trip spring from placing unnecessary force on the spool.

3. Cases with high set point only:

- a) To disable low trip, adjust low trip bolt until low trip occurs when piston is within 0.020 inch of bottom stop. Then adjust 3 turns upward (ccw viewed from above). Tighten locknut and check that low trip does not occur when piston travels to bottom stop.
- b) Adjust the high set point as described in 1.c) above.

IV RANGE SCREW ADJUSTMENT

This procedure describes the method of changing the range/span from the factory set range/span of the Hi Lo Pressurematic Pilot.

TOOLS: Range screw adjusting tool
Trip spring retainer
2 SAE wrenches/spanners -- 1/2" and 9/16"
hex key -- 3/16" short modified
SAE wrench/spanner -- 1-1/4"

NOTE: To make a change in the operating range/span values the trip spring (14) must be removed from the housing.

PROCEDURE:

1. To prevent VALVE OPERATOR travel, DISARM and DEPRESSURIZE the system or place selector in MANUAL MODE.
2. Depressurize "SENSE/PROCESS LINE(S)" to the pilot.
3. Remove the four cover bolts (20) and cover (21).
4. Install trip spring retainer onto the trip spring (14) near the LP adjusting bolt (15). This is done by hooking one end of the trip spring retainer under the bottom arm of the trip spring and prying down on the top arm to close the trip spring, then sliding the other end of the trip spring retainer over it. The spring can be compressed by hand if this retainer tool is not available. Refer to drawing I-0221.
5. Remove trip spring jam nut (12) and upper washer (23). Insert the 3/16 hex key in the top of the piston to lock it while loosening the jam nut.
6. It may be necessary to engage the HIGH TRIP BOLT (16) all the way up into the HOUSING (17) before the trip spring can be removed.
7. Remove the trip spring assembly by holding the trip spring retainer compressed by hand or by using the trip spring retainer as described in step 4 above.

NOTE: Take care not to bend the upper pilot spool (33) during trip spring (14) removal and replacement.

8. Remove trip spring lower washer (23) from the top of the piston (3).
9. Install range screw adjusting tool in range screw (11).
10. With use of 1-1/4 wrench/spanner turn the range screw clockwise to increase/raise the range value or counterclockwise to decrease/lower range value.

NOTE: If changing range spring (8) then remove range screw (11). Removal of old spring is done by means of a small wire hook to pull up on the spring. Install new spring and range screw. With use of the adjusting, tool adjust range screw one turn beyond hand tight. Proceed to the following range verification section.

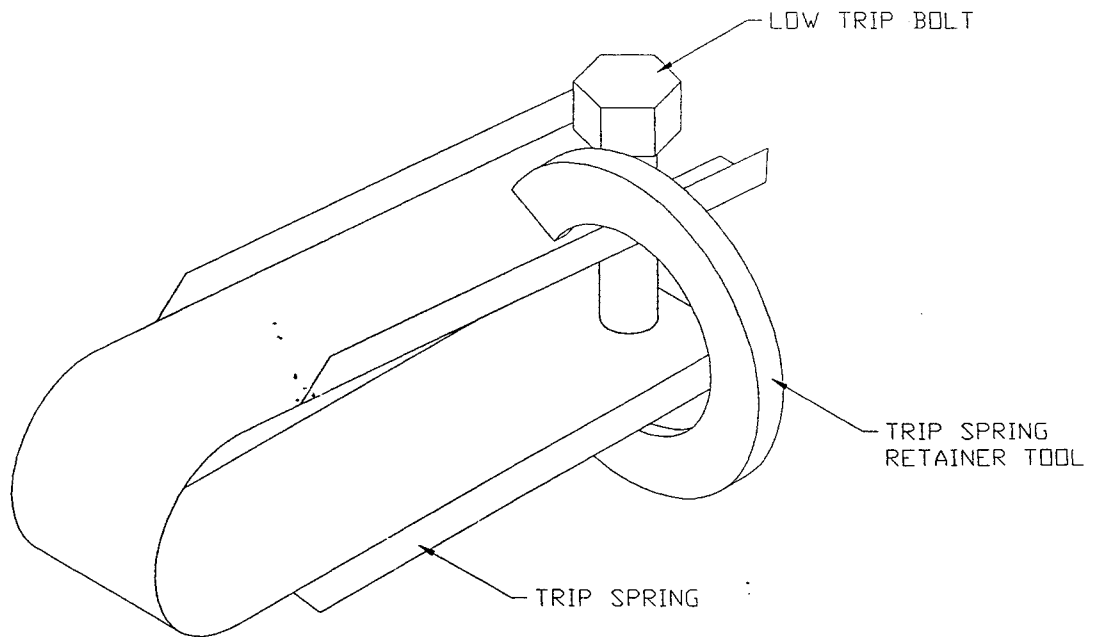
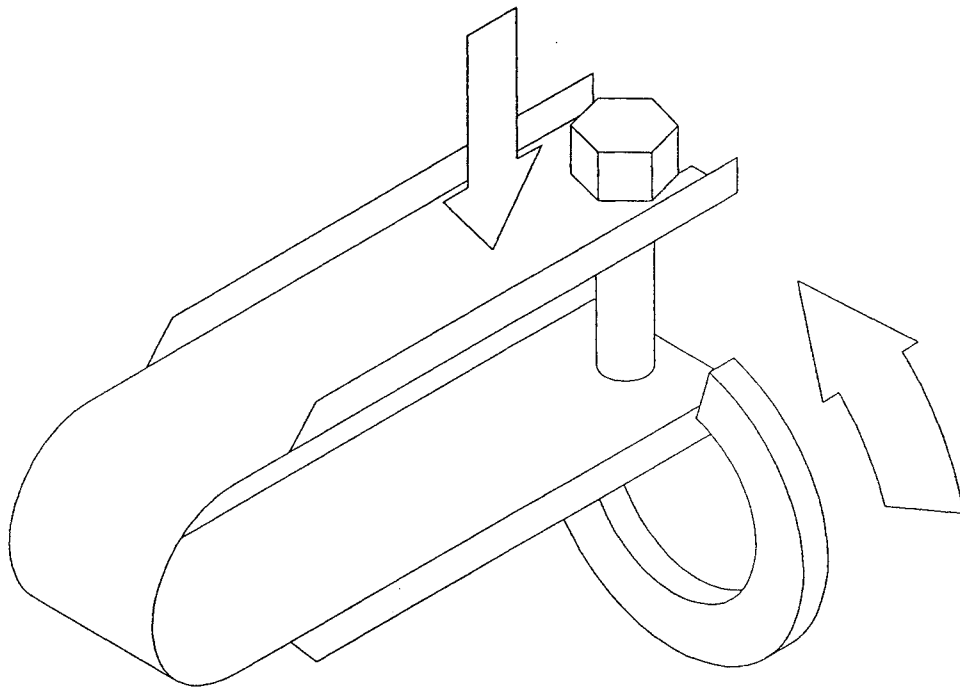

UNLESS SPECIFIED OTHERWISE ALL DIMENSIONS INCHES [mm]	
REV BY-DATE+REF	
TOLERANCES	
XXX	±0.5 [±10]
XX	±0.2 [±5]
X	±0.1 [±2]

BETTIS BETTIS CANADA LTD.	
Actuators & Controls	
TRIP SPRING RETAINER DIAGRAM	
I-0221--DWG_VIEW_00	
JAN-30-97	
SCALE	4:5
BY	RS
CHK	AA-#97-02-1E
DATE	JAN-30-97
W.D.	6053-1-B
DWG. NO.	I-0221
REV	--

V RANGE VERIFICATION PROCEDURE

Refer to calibration drawing APB0579.

NOTE: Total piston travel range is approximately 0.250 to 0.300 inches.

1. Connect a complete block and bleed valve test assembly with a gauge of suitable range to the sense/process port at the bottom of the pilot body (1).
2. Place a ruler or piece of paper behind the piston (3) to help observe the travel. Mark paper or note measurement at 0 psi.
3. Slowly increase the test pressure to the pilot body while observing the piston for signs of movement and watching gauge pressure. When upward movement begins, note gauge pressure reading to determine lower range limit.
4. Continue increasing pressure until piston travel ends, note gauge reading. This step determines the upper range limit.
5. Adjust the range screw as necessary to obtain an operating range/span with final gauge values outside the setpoints by 100 psi (700 kPA).

NOTE: If unable to obtain required range/span value, consult spring chart on the Range Table APB0579. If a more accurate range setting is required, a dial gauge will be needed to obtain a more precise reading of travel.

VI REASSEMBLY

1. Re-install trip spring assembly (14) onto the piston with a washer on each side of the trip spring.
2. Install jam nut on piston. Use 3/16 hex key to hold the piston stationary while tightening the jam nut.
3. Pry down on trip spring upper arm to allow removal of trip spring retainer.
4. Center trip spring in the housing. Spacing from guides of housing should be the same on left and right.
5. Go to Section I.6. for set point adjustment.

VII MODIFYING PRESSUREMATIC ASSEMBLY TYPE

Refer to drawings APB0570 and CB0066-10.

NOTE: To prevent VALVE OPERATOR travel, DISARM and DEPRESSURIZE the system or place selector in MANUAL MODE.
Depressurize "Sense/Process Line(s)" to the pilot.

1. Changing from P-AR to P-MR:

The conversion from the automatic reset to manual reset requires complete replacement of the three pilot body components. They must be machined to accept the manual reset manifold assembly. Contact BETTIS for more information.

2. Changing from P-MR to P-AR:

To change from manual reset to automatic reset, disconnect all tubing. Remove the bolts (103) from the reset valve body (101) and then remove the bolts (44) from the reset valve manifold (43). Reconnect all tubing to the ports on the remaining pilot bodies.

SERIES	SPRING	RANGE SCREW TURNS	SPAN (PSIG)		RANGE LIMIT (PSIG)		DEADBAND (PSIG)	
			MIN	MAX	LOW	HIGH	MIN	MAX
NOTE 2.		NOTE 4, 5.	NOTE 6.	NOTE 7.	NOTE 8.	NOTE 9.	NOTE 10.	NOTE 11.

2200	BLUE	0	55	105	10	(115)	25	--
	2" (-1)	7-1/4	65	115	(190)	305	--	40
	RED	0	90	180	15	(195)	25	--
	2" (-4)	5-1/2	95	200	(270)	470	--	65
	BRONZE	0	95	295	15	(310)	30	--
	2" (-7)	4	145	340	(385)	725	--	90
GREEN	0	130	395	20	(415)	35	--	
2" (-10)	3	160	430	(390)	820	--	95	

2000	BLUE	0	185	390	40	(430)	55	--
	2" (-1)	7-1/4	235	455	(745)	1200	--	130
	RED	0	280	680	55	(735)	75	--
	2" (-4)	5-1/2	320	770	(1060)	1830	--	185
	BRONZE	0	410	1190	80	(1270)	85	--
	2" (-7)	4	460	1310	(1550)	2860	--	255
GREEN	0	450	1480	140	(1620)	120	--	
2" (-10)	3	500	1670	(1580)	3250	--	265	

2400	BLUE	0	550	1120	85	(1205)	160	--
	2" (-1)	7-1/4	775	1270	(2050)	3320	--	425
	RED	0	720	1880	130	(2010)	195	--
	2" (-4)	5-1/2	950	2150	(3000)	5150	--	550
	BRONZE	0	1000	3220	230	(3450)	270	--
	2" (-7)	4	1400	3600	(4400)	8000	--	750
GREEN	0	1100	4100	400	(4500)	360	--	
2" (-10)	3	1650	4450	(4400)	8850	--	775	

NOTE:

- DATA BASED ON 110 PSIG AIR SUPPLY, ROOM TEMPERATURE AND 0.20"/.250" PISTON TRAVEL.
- SPECIFICATIONS: SERIES 2200, 1-1/4" PISTON DIA (MAVP 2800 PSD); SERIES 2000, 5/8" PISTON DIA (MAVP 3500 PSD); SERIES 2400, 3/8" PISTON DIA (MAVP 6000 PSD).
- ALLOW FOR DEVIATION FROM TABULATED VALUES OF ±10% DUE TO SPRING TOLERANCES AND OTHER VARIABLES. REPEATABILITY FOR A PARTICULAR SET-UP: ±2% OF SET POINT (5 PSI MIN).
- RANGE SCREW TURNS ARE COUNTED FROM A ZERO TURN REFERENCE POSITION. THIS IS WHERE THE RANGE SCREW FIRST MAKES CONTACT WITH THE SPRING WITH THE PISTON FULLY DOWN AND SENSED PRESSURE AT ZERO.
- THE RANGE SCREW MAY BE ADJUSTED AND VALUES INTERPOLATED BETWEEN EXTREMES GIVEN.
- MIN. SPAN IS THE MINIMUM DIFFERENCE BETWEEN HIGH AND LOW SET POINTS AT GIVEN RANGE SCREW SETTING.
- MAX. SPAN IS THE MAXIMUM DIFFERENCE BETWEEN HIGH AND LOW SET POINTS AT GIVEN RANGE SCREW SETTING.
- LOW RANGE LIMIT IS THE MINIMUM LOW SET POINT ATTAINABLE AT GIVEN RANGE SCREW SETTING AT OPTIMUM CONDITIONS OF TEMPERATURE AND FLUID VISCOSITY. VALUES IN PARENTHESES ARE DERIVED FROM MAXIMUM SPAN AT GIVEN RANGE SCREW SETTING.
- HIGH RANGE LIMIT IS THE MAXIMUM HIGH SET POINT ATTAINABLE AT GIVEN RANGE SCREW SETTING. VALUES IN PARENTHESES ARE DERIVED FROM MAXIMUM SPAN AT GIVEN RANGE SCREW SETTING.
- MIN. DEADBAND IS THE DIFFERENCE BETWEEN SET AND RESET POINTS NEAR LOW RANGE LIMIT.
- MAX. DEADBAND IS THE DIFFERENCE BETWEEN SET AND RESET POINTS NEAR HIGH RANGE LIMIT.
- REFER TO SHEET 2 OF 2 FOR A GRAPHICAL REPRESENTATION OF THE VALUES TABULATED HERE.

BETTS BETTIS CANADA LTD.

Accuracy Control

RANGE TABLE
FOR PRESSUREMATIC
P-AR/MR 2200/2000/2400

APB0579-DWG-VIEW_IDP2	DATE	SHEET 1 OF 2
SCALE N/A	BY DY	CHK M.L.P. J.S.B.
REV 18-97	DATE	DCT-04-91
VO. 8980-R&D	DWG. NO.	APB0579
REV 1-		

UPDT TB
Q.M.S-1997-08-18 86051-1-B
REV BY-DATE-REF

DWG. NO. APB0579

