

# PHP 25-05 Portable hand pump unit 5 l for BHH, BHHF and BL Actuators



## Description:

Double-acting portable hand pump including 5 l. reservoir and built-in 4/3-way pilot valve for opening and closing of valves mounted with Bettis actuators. The pump is mounted with female screw connections, which fit the male part mounted on Bettis connection and mounting blocks.

## Main data:

Max. system working pressure:	135 bar - (1960 PSi)
Max. system test pressure:	205 bar - (2970 PSi)
Max. hand pump pressure:	300 bar - (4300 PSi)
Safety valve settings:	180 bar - (2610 PSi)
Weight with 5 l. oil:	20 kg - (44 lbs)
Oil displacement per double stroke:	25 cm <sup>3</sup> - (1.525 in <sup>3</sup> )
Oil viscosity range:	15 - 300 cSt
Temperature range:	-15°C to 80°C - (5°F to 176°F)
Recommended oil filtration:	Should meet or be better than NAS 1630/10 or ISO Solid contaminant code 18/15
Standard hose:	4 m - (13 ft.) other hoses on request

## Operation:

### In a 2-line system

- Opening of valve:
- Close the stop valves on the control block mounted on the actuator.
  - Connect the hoses "B" and "A" to the emergency control block (e.g. HS-block) mounted on the actuator.
  - Turn the pilot valve on the hand pump to "open" position and continue to pump until the actuator or pressure gauge for nominal working pressure 105 (135) bar.
  - The valve is prevented from closing when the pilot valve is placed in centre position.

### Closing of valve:

- Turn the pilot valve on the hand pump to "closed" position - otherwise as above.

### In 1-line system

- Opening of valve:
- Only hose "B" is used - otherwise as above.

### Closing of valve:

- Turn the pilot valve on the hand pump to "closed" position.  
The actuator/valve closes without pumping.

Note: After operation disconnect the hoses from the control block on the actuator and open the stop valves again.

# Data sheet

Sheet No.: PHP01.02 RevA  
 Date: October 2010

# PHP 01

## Hydraulic diagram:

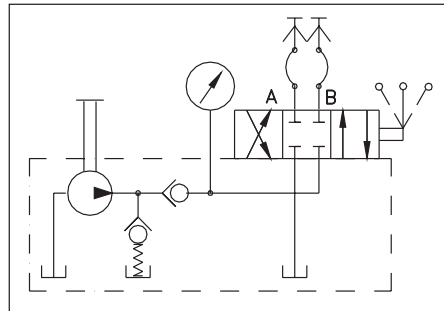

## Main dimensions: (Inches in parenthesis)

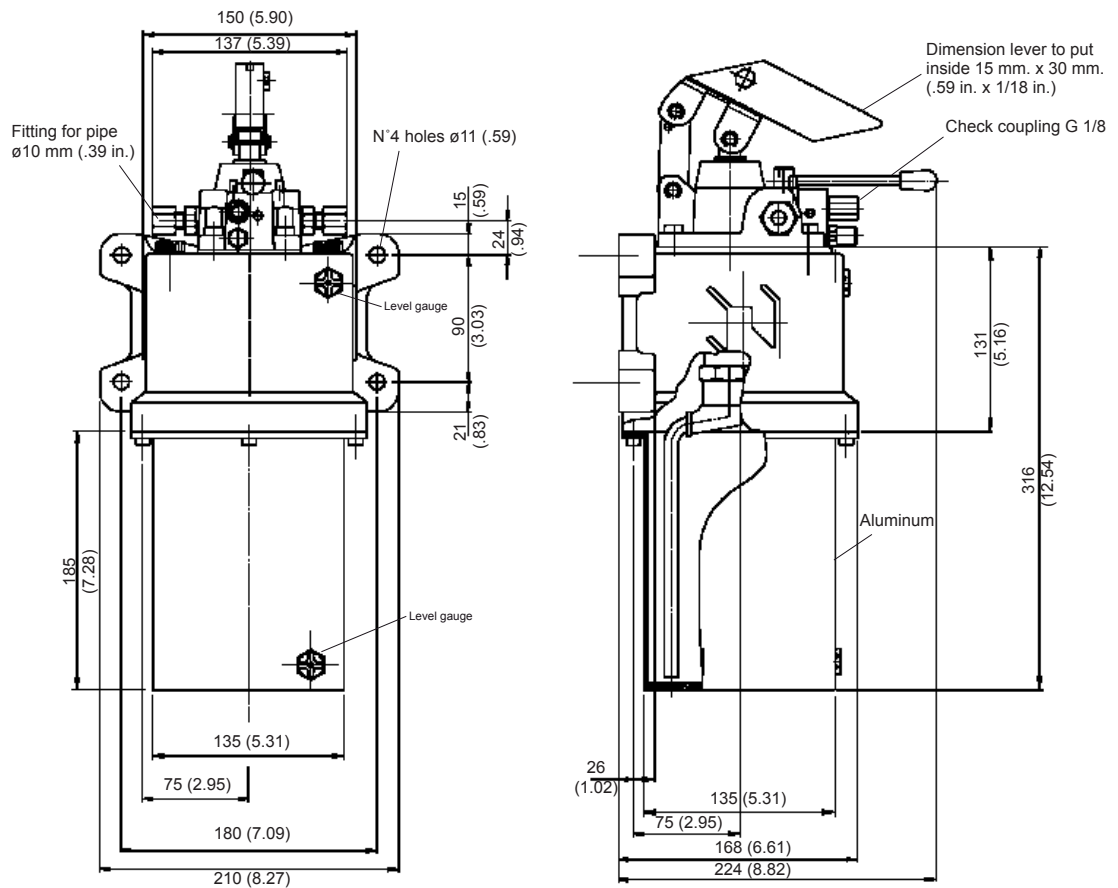

Note: Not Certified dimensional drawings. Such drawings are available on request. Contact factory with correct model designation and serial number.  
 Important: Due to Emerson's continuing commitment to engineered product advancement, data presented herein is subject to change.

The contents of the publication are presented for information purposes only, and while effort has been made to ensure their accuracy, they are not to be construed as warranties or guarantees, express or implied, regarding the products or services described herein or their use or applicability. All sales are governed by our terms and conditions, which are available on request. We reserve the right to modify or improve the designs or specifications of our products at any time without notice.



www.Bettis.com

Copyright © Emerson Process Management. The information in this document is subject to change without notice. Updated data sheets can be obtained from our website [www.bettis.com](http://www.bettis.com) or from your nearest Valve Automation Center.  
 USA: +1 281 727 5300 Europe: +31 74 256 1010 Asia-Pacific: +65 6501 4600

