

Bettis Hand Pump – Direct Mounted for BHH/BHHF Actuators



Description:

The direct mounted hand pump is installed directly on single and double line actuators i.e. no extra pipe or block installation is required. The direct mounted hand pump is mainly together with valves which are easy to access. For the main part of the double line actuators an additional tank is not needed, but for the biggest an additional tank must be

added to compensate for the oil compression and decompression. For the single line actuators an additional tank must always be added to operate the valve. A larger tank is also needed for the biggest single line actuators due to oil compression and decompression.

Application:

Hand pump type:

HP-D
HP-D-1
HP-S-1
HP-S-4

Range:

BHH 125 - 2000 & BL 65 -
BHH 4000 - 16000 & BL 250
BHHF 125 - 2000
BHHF 4000 - 16000

Please note that a BLF must be used instead of a BL actuator with a direct mounted hand pump.

Direct mounted hand pump for HP-D and BHH 500 and HP-S-1 and BHHF 500:

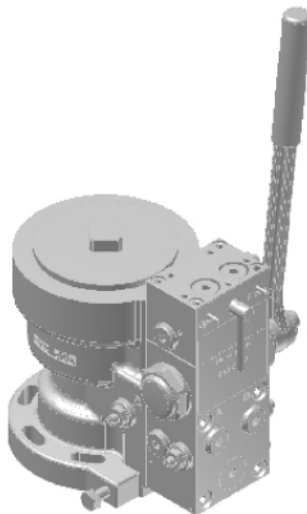

HP-D and BHH 500

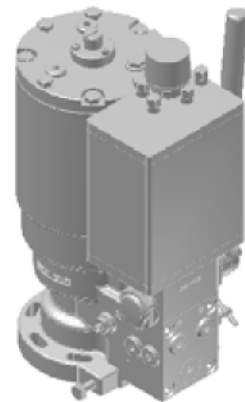

HP-S-1 and BHHF 500

Hydraulic diagram for HP-D-1:

ACTUATOR AREA

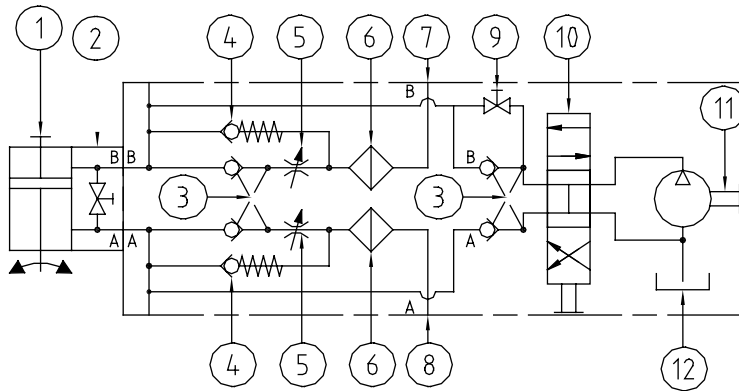

1. Double line actuator
2. Bypass valve
3. Double pilot operated
4. Check valve
5. Throttle valve
6. Filter
7. Remote connection line B (OPEN)
8. Remote connection line A (CLOSE)
9. Stop valve
10. Direction valve
11. Hand pump handle
12. Tank

Dimension for HP-D-1:

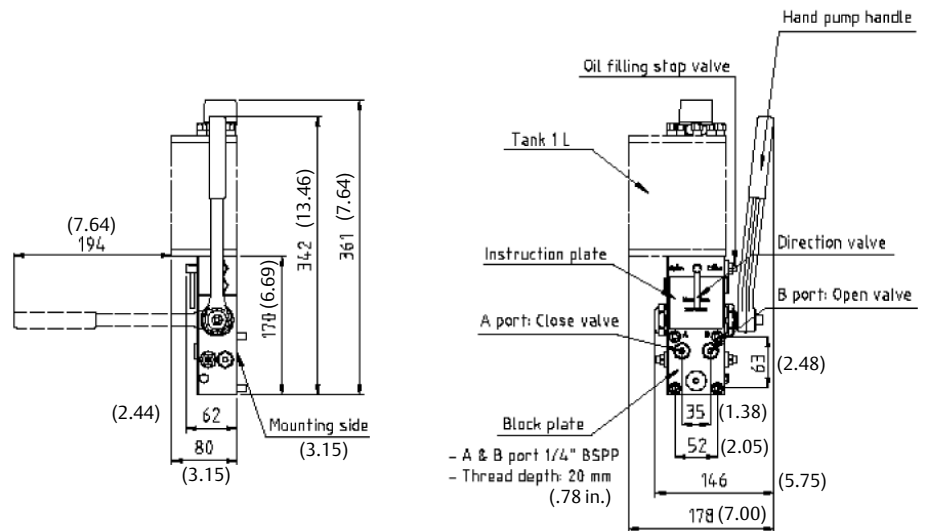

Hydraulic diagram for HP-S-1/-4:

ACTUATOR AREA

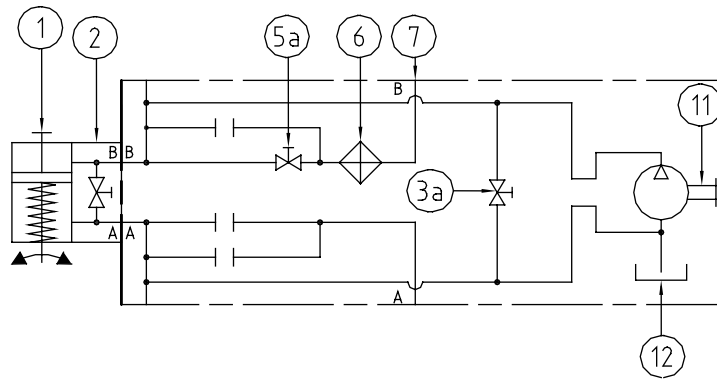

- 1. Single line actuator
- 2. Bypass valve
- 3a. Stop valve (2)
- 5a. Stop valve (1)
- 6. Filter
- 7. Remote connection line B (OPEN)
- 11. Hand pump handle
- 12. Tank

Dimensions for HP-S-1/-4:

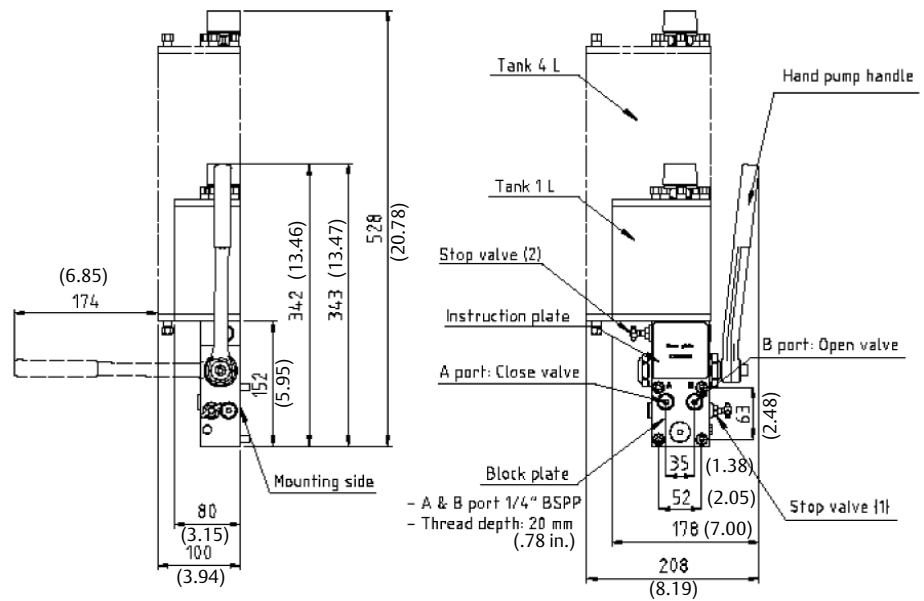

Note: Not Certified dimensional drawings. Such drawings are available on request. Contact factory with correct model designation and serial number. Important: Due to Emerson's continuing commitment to engineered product advancement, data presented herein is subject to change.

The contents of the publication are presented for information purposes only, and while effort has been made to ensure their accuracy, they are not to be construed as warranties or guarantees, express or implied, regarding the products or services described herein or their use or applicability. All sales are governed by our terms and conditions, which are available on request. We reserve the right to modify or improve the designs or specifications of our products at any time without notice.