

Data sheet

Sheet No.: CB-F01 RevA

Date: October 2010

CB-F01

CB-F control block for BHH/BHHF actuators

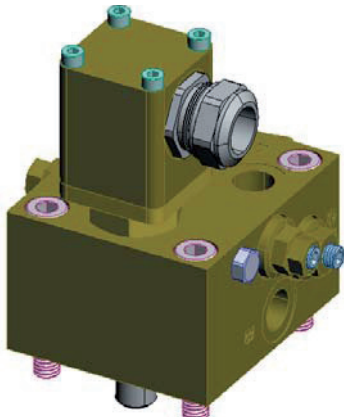

Presentation:

Control block for mounting on 1-line and 2-line actuators. This block is with a flush system and it is mounted with interface for EL on/off or potentiometer. It is prepared for pilot operated check valve, relief valve and throttle valve, stop valve and hand pump quick connections.

Available types:

- CBF 2-PCV-R-T-H-E
- CBF 2-PCV-R-T-E
- CBF 2-T-H-E
- CBF 2-T-E
- CBF 1-T-H-E
- CBF 1A-T-H-E

Main dimensions: (Inches in parenthesis)

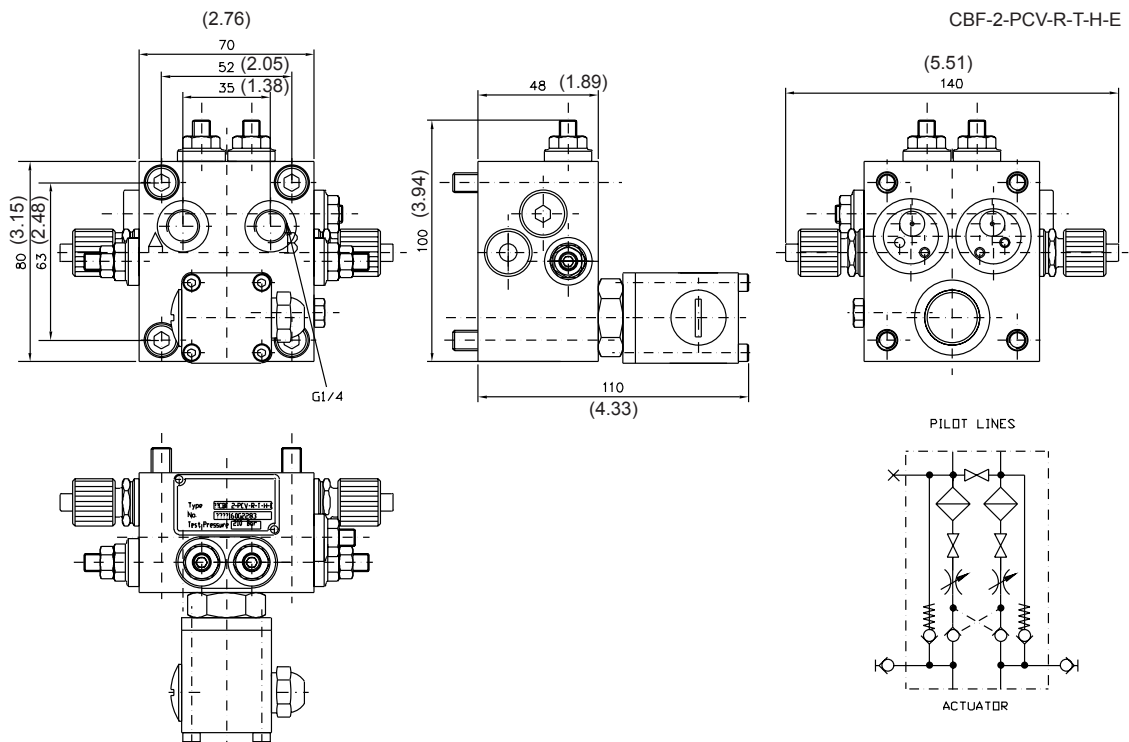

Note: Not Certified dimensional drawings. Such drawings are available on request. Contact factory with correct model designation and serial number.
Important: Due to Emerson's continuing commitment to engineered product advancement, data presented herein is subject to change.

The contents of the publication are presented for information purposes only, and while effort has been made to ensure their accuracy, they are not to be construed as warranties or guarantees, express or implied, regarding the products or services described herein or their use or applicability. All sales are governed by our terms and conditions, which are available on request.

We reserve the right to modify or improve the designs or specifications of our products at any time without notice.

BETTIS[™]

www.Bettis.com

Copyright © Emerson Process Management. The information in this document is subject to change without notice.

Updated data sheets can be obtained from our website www.bettis.com or from your nearest Valve Automation Center.

USA: +1 281 727 5300 Europe: +31 74 256 1010 Asia-Pacific: +65 6501 4600

EMERSON[™]
Process Management