

Cartridge based control block system for BHH/BHHF actuators

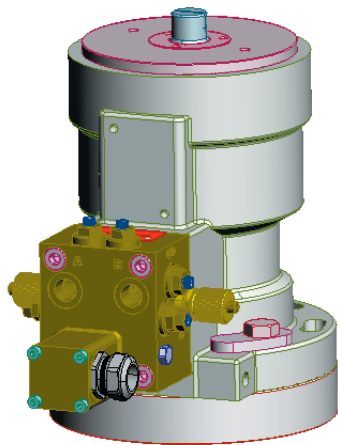

Description:

The control block is designed for mounting on, or close to the BHH or BHHF actuator. For use of other actuator types or if the actuator is submerged or placed in hazardous area the block can be connected to the pilot line by means of the B-block.

The control block system consists of 5 standard houses. Each standard house is divided in two separate parts. The top part has all the hydraulic functions and it is also divided in two parts - one for open and one for close- function, (A port: hydr. closing and B port: hydr. opening). The bottom part has the connection for direct position indication - either electrical (on/of or potentiometer) or

hydraulic (on/of).

Furthermore each standard block has several combination possibilities.

Hydraulic functions:

- Pilot line connection
- Flush system
- Last chance filter
- Throttle/stop valve
- Pilot-operated check valve
- Relief valve
- Quick connections
- By-pass hydraulic on/off indication

All hydraulic functions/connections can be used or plugged off.

Operation:

The pilot-operated check valve is to, hydraulically lock the piston on the actuator and prevent the actuator from moving when it is required to be held stationary. Double pilot check valves are tested to ensure zero leakage, but care must be taken to ensure that the hydraulic oil in the system is free from any foreign particles that may cause damage to the seats or the hydraulic sealing ring in the pilot piston.

The relief valve secures that the oil pressure do not rise above the DPCV open pressure.

The throttle valve controls the speed of the actuator. It allows regulation of flow in both directions. The throttle/stop valve is used to isolate the actuator if emergency

operation is required.

The throttle valve and the throttle/stop valve are not compensated for pressure or temperature variations.

The quick connections are used for emergency operation by means of the Bettis' portable hand pump. The quick connections can be replaced with an adaptor (max. 19 AF) if operation is to be elsewhere than on the actuator.

The CETOP 3 block interface is according to ISO 4401/NG6 DIN 24340 except that the oil canals is $\varnothing 7$ instead of max. $\varnothing 6.3$.

By-pass indication - DPI-B: please see separate data sheet.

Type codes:

- CB: Control Block
- 2: 2-line actuator (BHH...)
- 1: 1-line actuator (BHHF...)
- 1A: 1-line actuator (BHHF... Fail open)
- S: Throttle/Stop valve
- PCV: Pilot operated Check valve
- R: Relief valve

- T: Throttle valve
- H: Quick connection for hand pump
- E: Interface for EL on/off or potentiometer, 0-100%
- B: By-pass hydraulic on/off indication
- NG6: Interface for CETOP 3 valves
- CBF: CB + Flush system

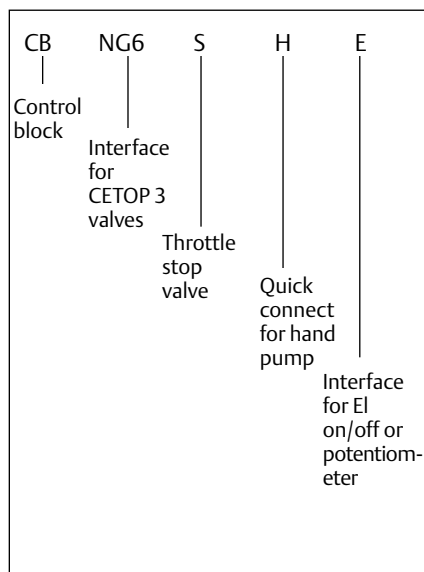

Example

Main materials:

Block:	Brass - CuZn39Pb3
Valve parts:	Brass - CuZn39Pb3/ acid proof steel
Screws:	Acid proof steel
Seals:	NBR/teflon

Main specifications:

Working pressure:	135 bar	(1958 PSi)
Test pressure:	210 bar	(3045 PSi)
Burst pressure:	600 bar	(8700 PSi)
Relief crack pressure:	150-250 bar	(2175-3625 (PSi)
Check valve ratio:	3:1	
Max. flow:	6 L/min.	
Min. flow with use of throttle valve:	120-180 ml/min.	
Temperature range:	-20° C to +80° C (-4° F to + 176° F)	
Hydraulic media:	Acid free hydraulic oil	
Viscosity range:	15-200 cSt	
Filtration (ISO):	18/16/13	

Max. weight for each standard block:	Type:	Weight: kg	(lb)
	CB	1.75	(4.69)
	CB-E	2.75	(7.36)
	CB-B	2.3	(6.16)
	CB-NG6	2.8	(7.50)
	CBF	2.8	(7.50)
	E-block	1.5	(4.02)
	B-block	2.0	(5.36)
	Adaptor	1.75	(4.69)

Further information about each standard block please see separate data sheets.

Note:

All H: Quick connection for portable hand pump. Can also be remotely installed.
 For continuous or on/off indication - (DPI-C, DPI-E or DPI-B) please see separate data sheets.

For further information please contact Emerson.

Note: Not Certified dimensional drawings. Such drawings are available on request. Contact factory with correct model designation and serial number.
 Important: Due to Emerson's continuing commitment to engineered product advancement, data presented herein is subject to change.

The contents of the publication are presented for information purposes only, and while effort has been made to ensure their accuracy, they are not to be construed as warranties or guarantees, express or implied, regarding the products or services described herein or their use or applicability. All sales are governed by our terms and conditions, which are available on request.
 We reserve the right to modify or improve the designs or specifications of our products at any time without notice.